



MAGNETROL®

AMETEK®

**LEVEL MEASUREMENT
SOLUTIONS**

Displacer Type Liquid Level Switches

DESCRIPTION

Magnetrol® displacement type level switches offer the industrial user a wide choice of alarm and control configurations. Every unit utilizes a simple buoyancy principle and is well suited for simple or complex applications, such as foaming or surging liquids or agitated fluids, and usually costs less than other types of level switches.

FEATURES

- Narrow or wide level ranges achieved through multiple switch mechanism capability.
- Up to 4 set points and 3 switches.
- Displacers adjustable at any point along the suspension cable.
- 10 feet (3 meters) suspension cable standard.
- Anti-surge design eliminates the possibility of switch shortcycling.
- Flanged or threaded mounting available.
- Easy installation.
- Field adjustable set point and switch differential.
- NACE models.
- Floating rooftop models.
- Proof-er® ground check.
- Choice of displacers: Porcelain, 316 Stainless steel, Karbate, Brass.
- Choice of switch mechanisms: Dry contact, Pneumatic, Hermetically sealed.
- Available housings: NEMA 1, carbon steel for pneumatics; TYPE 4X/7/9, Class I, Div. 1, Groups C & D, polymer coated aluminum; TYPE 4X/7/9, Class I, Div. 1, Group B, polymer coated aluminum.



**Displacer
Level Switch**

**Displacer
Level Switch
with PROOF-ER**

APPLICATIONS

- Foaming or surging liquids
- Agitated fluids
- Sewage handling
- Dirty liquids
- Paints
- Varnishes
- Heavy oils
- Liquids with solids

TECHNOLOGY

Operation is based upon simple buoyancy, whereby a spring is loaded with weighted displacers which are heavier than the liquid. Immersion of the displacers in the liquid results in buoyancy force change, which moves the spring upward.

Since the spring moves only when the level moves on a displacer, spring movement ① is always a small fraction of the level travel between displacers ②.

A magnetic sleeve ③ is connected to the spring and operates within a non-magnetic barrier tube ④. Spring movement causes the magnetic sleeve to attract a pivoted magnet ⑤, actuating a switch mechanism ⑥ located outside the barrier tube. Built-in limit stops prevent over stroking of the spring, under level surge conditions.

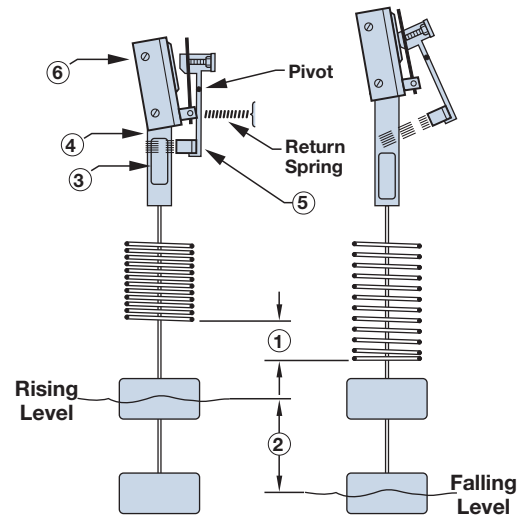

PROOF-ER CONTROLS

The purpose of the PROOF-ER is to check the operation of a displacer control without having to raise the level in the tank. This is accomplished by pulling downward on the PROOF-ER chain. A spring-loaded lever arm then lifts

the switch actuator simulating a high or high-high level condition. When the chain is released, the PROOF-ER returns the actuator to its previous position to resume normal operation.

FLOATING ROOFTOP CONTROLS

The floating rooftop control is designed for installation on "barrier" (floating roof) tanks. The control will be furnished with a brass weight displacer to prevent sparking.

A hollow brass displacer is required if the control is to actuate in liquid as well as by the barrier. Consult factory for other options.

DISPLACERS

Stainless steel displacers are rated 720 psig @ +100 °F (50 bar @ +38 °C).

Karbate displacers are limited to a minimum temperature of +32 °F (0 °C) and a maximum temperature of +300 °F (+149 °C).

Do not use porcelain displacers on non-vented boiler water condensate systems over +200 °F (+93 °C). Stainless steel or Karbate is recommended.

DISPLACERS SUSPENSION CABLE

Displacers are field-adjustable at any point along the suspension cable (10 feet (3 meters) 316 stainless steel is

standard). Monel® and Hastelloy® materials are available. Consult the factory for longer lengths.

SINGLE SWITCH MODELS

SERIES A10 AND SERIES A15

SERIES A10 PUMP OR VALVE CONTROL WIDE DIFFERENTIAL TYPE

These wide differential units are factory calibrated to actuate as a liquid level reaches a given displacer and to deactuate when the level reaches a second displacer.

The minimum differential band is approximately 6 in. (152 mm) in water and varies somewhat with liquid specific gravity. The maximum differential is determined by the length of the displacer suspension cable.

SERIES A15 LEVEL ALARM APPLICATIONS NARROW DIFFERENTIAL TYPE

These instruments are factory calibrated to operate over a narrow level differential band and are ideally suited for liquid level alarm applications on either high or low level.

The operating level is fully adjustable simply by repositioning the displacer along its suspension cable. The differential band varies slightly with liquid specific gravity.

DUAL SWITCH MODELS

SERIES B10 AND SERIES B15

SERIES B10 WIDE DIFFERENTIAL TYPE

These wide differential tandem units are factory calibrated with a choice of several operating sequences designed to meet virtually any application.

OPERATING SEQUENCES

Model B10 units are available with a choice of switch operating sequence. Five of the most popular sequences are described on page 8. When ordering, specify operating sequence number and specific gravity of the liquid.

SERIES B15 NARROW DIFFERENTIAL TYPE

These instruments utilize two switches — each actuated at a different level and each calibrated with a narrow differential band.

TRI-SWITCH MODELS

SERIES C10 AND SERIES C15

SERIES C10 WIDE DIFFERENTIAL TYPE





These wide differential type switches are designed to provide three electrically separate control signals in a selected sequence as liquid level varies.

These units come factory-calibrated with a choice of several operating sequences combining wide and narrow level differential.

SERIES C15 NARROW DIFFERENTIAL TYPE

These instruments are factory-calibrated to operate over a narrow level band while providing three electrically separate control signals as liquid level varies.

AGENCY APPROVALS

| AGENCY | APPROVED MODEL | AREA CLASSIFICATION |
|--|---|--|
| FM  | All with an electric switch mechanism and a housing listed as Type 4X/7/9 | Class I, Div 1, Groups C & D Class II, Div 1, Groups E, F & G |
| | All with an electric switch mechanism and a housing listed as Type 4X/7/9 Class I, Div 1, Group B | Class I, Div 1, Groups B, C & D Class II, Div 1, Groups E, F & G |
| CSA  | All with a Series HS, F, 8 or 9 electric switch mechanism and a housing listed as CSA Type 4X | Class I, Div 2, Groups A, B, C & D |
| | All with an electric switch mechanism and a housing listed as Type 4X/7/9 | Class I, Div 1, Groups C & D Class II, Div 1, Groups E, F & G |
| | All with an electric switch mechanism and a housing listed as Type 4X/7/9 Class I, Div 1, Group B | Class I, Div 1, Groups B, C & D Class II, Div 1, Groups E, F & G |
| ATEX / IEC Ex ^②  | All with an electric switch mechanism and an ATEX housing ^① | ATEX II 2 G Ex d IIC T6 94/9/EC IEC Ex Ex d IIC T6 IP66 |
| CE  | All models | Installation Category II Pollution Degree 2 Low Voltage Directives 2006/95/EC per Harmonized Standard EN 61010-1/1993 & Amendment No. 1 |

① Controls with two or more HS or H1 switches are not ATEX approved.

② IEC Installation Instructions:

The cable entry and closing devices shall be Ex d certified suitable for the conditions of use and correctly installed.

For ambient temperatures above +55 °C or for process temperatures above +150 °C, suitable heat resistant cables shall be used.

Heat extensions (between process connection and housing) shall never be insulated.

Special conditions for safe use:

When the equipment is installed in process temperatures higher than +85 °C the temperature classification must be reduced according to the following table as per IEC60079-0.

| Maximum Process Temperature | Temperature Classification |
|-----------------------------|----------------------------|
| < 85 °C | T6 |
| < 100 °C | T5 |
| < 135 °C | T4 |
| < 200 °C | T3 |
| < 300 °C | T2 |
| < 450 °C | T1 |

These units are in conformity with IECEx KEM 05.0020X
Classification Ex d IIC T6
T_{ambient} -40 °C to +70 °C

PRESSURE / TEMPERATURE RATINGS

| | |
|---------------------------------|--|
| Threaded Models ^{③ ④} | 800 psig @ +100 °F (55 bar @ +38 °C) 250 psig @ +500 °F (17 bar @ +260 °C) |
| Flanged Models ^④ | Limited to the pressure rating of the selected flange or displacer. Flanges conform to ASME B16.5. |
| Low Pressure PROOF-ER Models | 25 psig @ +200 °F (1.7 bar @ +93 °C) |
| Medium Pressure PROOF-ER Models | 125 psig @ +300 °F (8.6 bar @ +149 °C) |

③ Models with stainless steel displacers are rated 720 psig @ +100 °F (50 bar @ 38 °C).

④ Cryogenic construction available upon request. Consult factory with application details.

SPECIFICATIONS

SWITCH MECHANISMS AND ENCLOSURES



SERIES B, C, D, O & Q DRY CONTACT SWITCHES

- Series “B”, “C”, “O” and “Q” switches are general purpose units with a selection of maximum liquid temperature ratings
- Series “D” switch is designed for high DC current applications



SERIES J & K PNEUMATIC SWITCHES

- Suited for process industry applications in hazardous locations or where electrical power is not available
- Series “J” bleed type switch is intended for general purpose applications
- Series “K” switch is specially designed to provide non-bleed operation with a high degree of vibration resistance



SWITCH ENCLOSURES

- TYPE 4X/7/9 aluminum enclosures
- Designed and approved for Class I, Div. 1, Groups C & D and Class I, Div. 1 Group B
- Optional housing heaters and drains available for some enclosures
- Pneumatic switch mechanisms available with a NEMA 1 enclosure



SERIES HS, F & 8 HERMETICALLY SEALED SWITCHES

- Entire mechanism and contacts are contained within a positively pressurized capsule with series ‘HS’
- Ideal for use in salt and other corrosive atmospheres
- Available in two models, one with easy access terminals, another with 12" (305 mm) long exposed wiring leads which may be field connected away from the switch enclosure

BASIC ELECTRICAL RATINGS

| Voltage | Switch Series and Non-Inductive Ampere Rating | | | | | | | |
|---------|---|-------|-------|------|------|-------|-------|------|
| | B | C | D | F | HS | O | Q | 8 |
| 120 VAC | 15.00 | 15.00 | 10.00 | 2.50 | 5.00 | 15.00 | 15.00 | 1.00 |
| 240 VAC | 15.00 | 15.00 | — | — | 5.00 | 15.00 | 15.00 | — |
| 24 VDC | 6.00 | 6.00 | 10.00 | 4.00 | 5.00 | 6.00 | 6.00 | 3.00 |
| 120 VDC | 0.50 | 1.00 | 10.00 | 0.30 | 0.50 | 1.00 | 0.50 | — |
| 240 VDC | 0.25 | 0.50 | 3.00 | — | 0.25 | 0.50 | 0.25 | — |

SPECIFICATIONS

MODEL A10 DIMENSIONAL DATA AND ACTUATION LEVELS

INCHES (MM)

| Outline Dimensions | | | | |
|----------------------------|-------------------|---------------|------------------|---------------|
| Displacer Type | Threaded Mounting | | Flanged Mounting | |
| | A | B | A | B |
| Porcelain | 5.00 (127) | 242.00 (6146) | 7.00 (177) | 244.00 (6197) |
| Stainless Steel or Karbate | 4.75 (120) | 242.00 (6146) | 6.75 (171) | 244.00 (6197) |

| Displacer Type | C | D | E |
|----------------------------|-----------|------------|------------|
| Porcelain | 2.56 (65) | 7.25 (184) | 3.62 (91) |
| Stainless Steel or Karbate | 2.50 (63) | 9.00 (228) | 4.50 (114) |

| Electrical Connections |
|--|
| TYPE 4X/7/9, Group B: 1" NPT NEMA 1 Pneumatic: 1/4" NPT |

STANDARD ACTUATING LEVELS AND LIQUID SPECIFIC GRAVITY

| Displacer Type | Liquid Temp. °F | 0.60 | | 0.70 | | 0.80 | | 0.90 | | 1.00 | |
|----------------------------|-----------------|------------|-----------|------------|-----------|------------|-----------|------------|-----------|-----------|-----------|
| | | F | G | F | G | F | G | F | G | F | G |
| Porcelain | 100 | 5.30 (134) | 1.50 (38) | 4.10 (104) | 1.20 (30) | 3.20 (81) | 1.10 (27) | 2.50 (63) | 1.00 (25) | 2.00 (50) | 0.90 (22) |
| | 200 | — | — | 4.80 (121) | 2.00 (50) | 3.80 (96) | 1.80 (45) | 3.00 (76) | 1.60 (40) | 2.50 (63) | 1.50 (38) |
| | 300 | — | — | — | — | 4.30 (109) | 2.40 (60) | 3.40 (86) | 2.10 (53) | 2.90 (73) | 1.90 (48) |
| | 400 | — | — | — | — | — | — | 3.40 (86) | 2.60 (66) | 2.90 (73) | 2.40 (60) |
| Stainless Steel or Karbate | 100 | 7.00 (177) | 2.40 (60) | 5.30 (134) | 2.00 (50) | 4.10 (104) | 1.80 (45) | 3.10 (78) | 1.60 (40) | 2.40 (60) | 1.40 (35) |
| | 200 | — | — | 5.90 (149) | 2.80 (71) | 4.70 (119) | 2.50 (63) | 3.60 (91) | 2.20 (55) | 2.80 (71) | 2.00 (50) |
| | 300 | — | — | — | — | 5.10 (129) | 3.10 (78) | 4.00 (101) | 2.70 (68) | 3.20 (81) | 2.40 (60) |
| Stainless Steel | 400 | — | — | — | — | — | — | 4.40 (111) | 3.20 (81) | 3.60 (91) | 2.90 (73) |
| | 500 | — | — | — | — | — | — | — | — | 3.90 (99) | 3.30 (83) |

Note: All levels $\pm 0.25"$ (6).

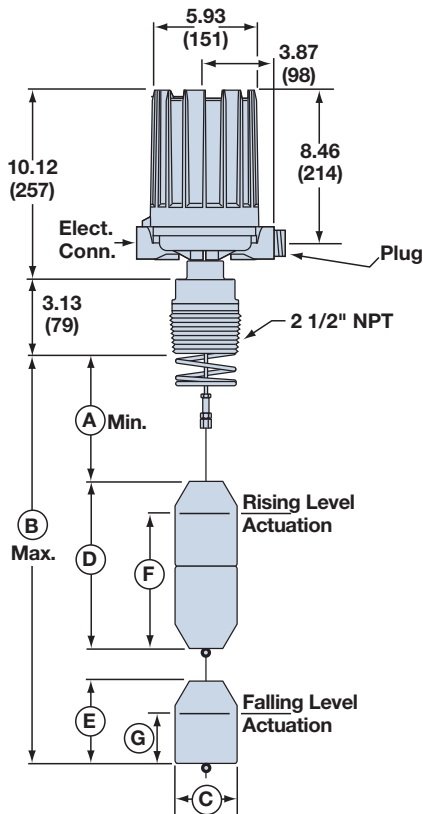

Model A10
with Threaded Mounting

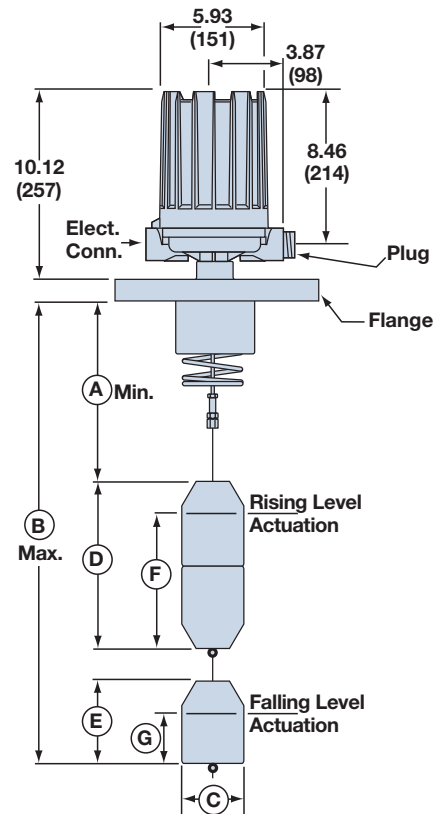

Model A10
with Flanged Mounting

SPECIFICATIONS

MODEL A15 DIMENSIONAL DATA AND ACTUATION LEVELS *

INCHES (MM)

| Outline Dimensions | | | | |
|--|-------------------|---------------|------------------|---------------|
| Displacer Type | Threaded Mounting | | Flanged Mounting | |
| | A | B | A | B |
| Porcelain | 5.62 (142) | 242.00 (6146) | 7.62 (193) | 244.00 (6197) |
| Stainless Steel, Karbate or Hollow Brass | 5.62 (142) | 242.00 (6146) | 7.62 (193) | 244.00 (6197) |

| Displacer Type | C | D |
|--|-----------|------------|
| Porcelain | 2.56 (65) | 7.25 (184) |
| Stainless Steel, Karbate or Hollow Brass | 2.50 (63) | 9.00 (228) |

| Electrical Connections |
|--|
| TYPE 4X/7/9, Group B: 1" NPT NEMA 1 Pneumatic: 1/4" NPT |

STANDARD ACTUATING LEVELS AND LIQUID SPECIFIC GRAVITY

| Displacer Type | Liquid Temp. °F | 0.50 | | 0.60 | | 0.70 | | 0.80 | | 0.90 | | 1.00 | |
|--|-----------------|------------|-----------|------------|-----------|------------|-----------|------------|-----------|------------|-----------|------------|-----------|
| | | E | F | E | F | E | F | E | F | E | F | E | F |
| Porcelain | 100 | — | — | 5.10 (129) | 2.10 (53) | 4.50 (114) | 1.70 (43) | 3.90 (99) | 1.70 (43) | 3.50 (88) | 1.50 (38) | 3.20 (81) | 1.40 (35) |
| | 200 | — | — | 5.60 (142) | 2.60 (66) | 4.90 (124) | 2.10 (53) | 4.30 (109) | 2.10 (53) | 3.80 (96) | 1.80 (45) | 3.50 (88) | 1.70 (43) |
| | 300 | — | — | — | — | 5.20 (132) | 2.40 (60) | 4.50 (114) | 2.30 (58) | 4.10 (104) | 2.10 (53) | 3.70 (93) | 1.90 (48) |
| | 400 | — | — | — | — | 5.60 (142) | 2.80 (71) | 4.80 (121) | 2.60 (66) | 4.30 (109) | 2.30 (58) | 3.90 (99) | 2.10 (53) |
| | 500 | — | — | — | — | — | — | 5.10 (129) | 2.90 (73) | 4.60 (116) | 2.60 (66) | 4.20 (106) | 2.40 (60) |
| Stainless Steel, Karbate or Hollow Brass | 100 | 5.40 (137) | 2.00 (50) | 4.50 (114) | 1.60 (40) | 3.90 (99) | 1.40 (35) | 3.40 (86) | 1.20 (30) | 3.00 (76) | 1.10 (27) | 2.70 (68) | 1.00 (25) |
| | 200 | 6.00 (152) | 2.60 (66) | 5.00 (127) | 2.10 (53) | 4.30 (109) | 1.80 (45) | 3.70 (93) | 1.60 (40) | 3.30 (83) | 1.40 (35) | 3.00 (76) | 1.30 (33) |
| | 300 | 6.40 (162) | 3.00 (76) | 5.30 (134) | 2.40 (60) | 4.60 (116) | 2.10 (53) | 4.00 (101) | 1.80 (45) | 3.60 (91) | 1.70 (43) | 3.20 (81) | 1.50 (38) |
| Stainless Steel | 400 | 6.90 (175) | 3.50 (88) | 5.70 (144) | 2.80 (71) | 4.90 (124) | 2.40 (60) | 4.30 (109) | 2.10 (53) | 3.80 (96) | 1.90 (48) | 3.40 (86) | 1.70 (43) |
| | 500 | — | — | 6.10 (154) | 3.20 (81) | 5.20 (132) | 2.80 (71) | 4.60 (116) | 2.40 (60) | 4.10 (104) | 2.20 (55) | 3.70 (93) | 2.00 (50) |

Note: All levels ±0.25" (6).

*See page 21 for PROOF-ER and/or floating rooftop switch dimensions.

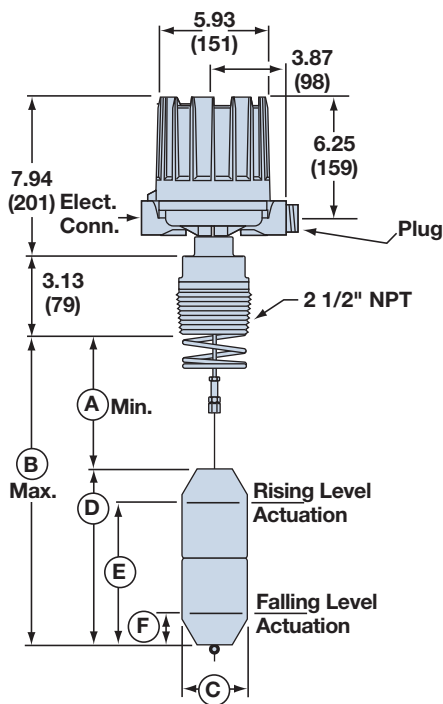

Model A15
with Threaded Mounting

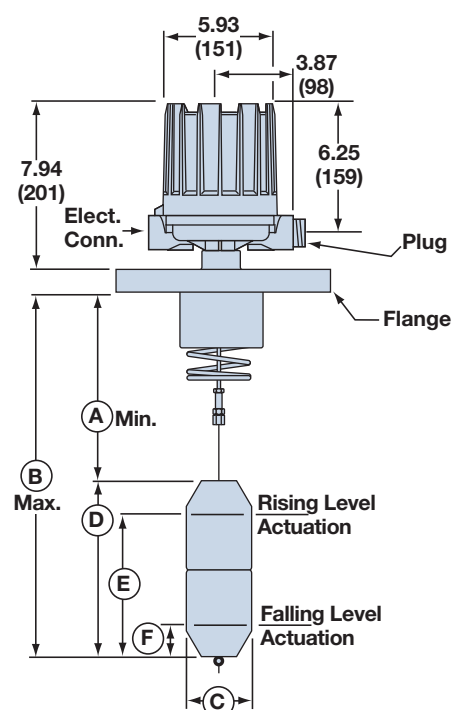

Model A15
with Flanged Mounting

SPECIFICATIONS

MODEL B10 DIMENSIONAL DATA

INCHES (MM)

| Outline Dimensions | | | | |
|-------------------------------|-------------------|------------------|------------------|------------------|
| Displacer Type | Threaded Mounting | | Flanged Mounting | |
| | A | B | A | B |
| Porcelain | 4.88 (123) | 242.00 (6146) | 6.88 (174) | 244.00 (6197) |
| Stainless Steel or Karbate | 4.75 (120) | 242.00 (6146) | 6.75 (171) | 244.00 (6197) |

MODEL B10 WITH DISPLACER ARRANGEMENTS 3, 4, AND 5

| Displacer Type | C | D | E | F |
|-------------------------------|--------------|---------------|---------------|---------------|
| Porcelain | 2.56 (65) | 5.02 (127) | 5.02 (127) | 5.02 (127) |
| Stainless Steel or Karbate | 2.50 (63) | 6.00 (152) | 6.00 (152) | 6.00 (152) |

MODEL B10 WITH DISPLACER ARRANGEMENTS 1 AND 2

| Displacer Type | C | D | E |
|-------------------------------|-----------|-------------|------------|
| Porcelain | 2.56 (65) | 10.04 (255) | 5.02 (127) |
| Stainless Steel or Karbate | 2.50 (63) | 12.00 (304) | 6.00 (152) |

Electrical Connections

TYPE 4X/7/9
Group B: 1" NPT

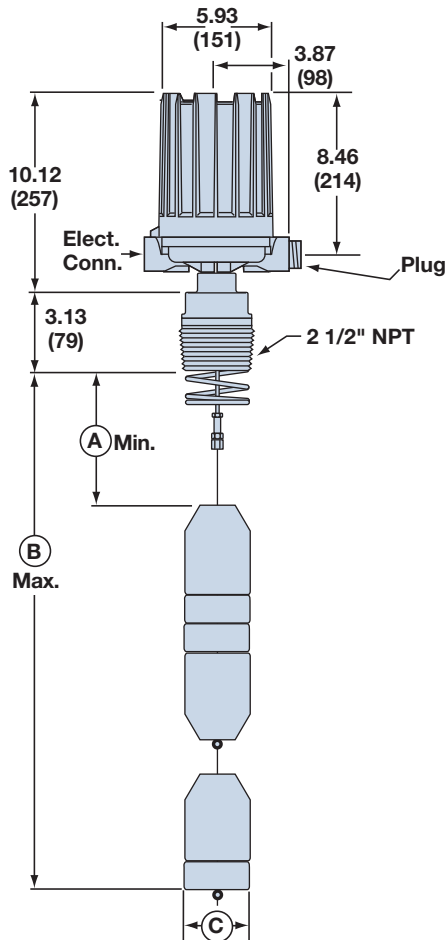

Model B10
with Threaded Mounting

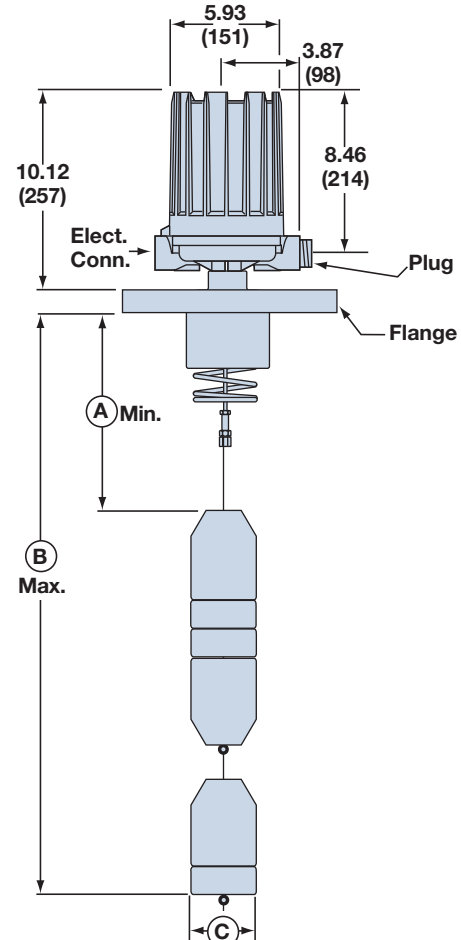

Model B10
with Flanged Mounting

SPECIFICATIONS

MODEL B10 ACTUATION LEVELS

INCHES (MM)

B10 STANDARD ACTUATING LEVELS AND LIQUID SPECIFIC GRAVITY WITH DISPLACER ARRANGEMENT 1

| Displacer Type | Liquid Temp. °F | Level | 0.60 - 0.64 | 0.65 - 0.71 | 0.72 - 0.73 | 0.74 - 0.82 | 0.83 - 0.92 | 0.93 - 1.00 | 1.01 - 1.07 |
|----------------|-----------------|-------|----------------------------|----------------------------|----------------------------|----------------------------|----------------------------|----------------------------|----------------------------|
| Porcelain | 100 | F | 7.79 - 7.04 (197 - 178) | 7.66 - 6.65 (194 - 168) | 7.22 - 7.06 (133 - 179) | 6.91 - 5.81 (175 - 147) | 6.73 - 5.65 (180 - 143) | 5.55 - 4.86 (140 - 123) | 4.97 - 4.53 (126 - 115) |
| | | G | 2.62 - 2.19 (56 - 55) | 2.88 - 2.28 (73 - 57) | 2.91 - 2.81 (73 - 71) | 2.71 - 2.03 (68 - 51) | 2.99 - 2.28 (75 - 57) | 2.21 - 1.76 (56 - 44) | 1.90 - 1.63 (48 - 41) |
| | | H | 2.01 - 1.89 (51 - 48) | 1.86 - 1.70 (47 - 43) | 1.68 - 1.65 (42 - 41) | 1.63 - 1.47 (41 - 37) | 1.45 - 1.31 (36 - 33) | 1.30 - 1.21 (33 - 30) | 1.02 - 0.97 (25 - 24) |
| | 200 | F | 7.91 (200) | 7.72 - 6.71 (196 - 170) | 6.56 - 6.41 (166 - 162) | 6.73 - 5.66 (170 - 143) | 6.37 - 5.33 (161 - 135) | 6.15 - 5.42 (156 - 137) | 5.02 - 4.57 (127 - 116) |
| | | G | 3.06 (77) | 2.95 - 2.34 (74 - 59) | 2.25 - 2.16 (57 - 54) | 2.54 - 1.87 (64 - 47) | 2.63 - 1.95 (66 - 49) | 2.81 - 2.32 (71 - 58) | 1.94 - 1.67 (49 - 42) |
| | | H | 2.76 (70) | 2.72 - 2.49 (69 - 63) | 2.45 - 2.42 (62 - 61) | 2.39 - 2.15 (60 - 54) | 2.13 - 1.92 (54 - 48) | 1.90 - 1.77 (48 - 44) | 1.58 - 1.49 (40 - 37) |
| | 300 | F | — | — | — | 7.48 - 6.34 (189 - 161) | 7.04 - 5.93 (178 - 150) | 6.75 - 5.98 (171 - 151) | 5.57 - 5.10 (141 - 129) |
| | | G | — | — | — | 3.29 - 2.55 (83 - 64) | 3.30 - 2.56 (83 - 65) | 3.41 - 2.87 (86 - 72) | 2.50 - 2.19 (63 - 55) |
| | | H | — | — | — | 3.14 - 2.83 (79 - 71) | 2.80 - 2.53 (71 - 64) | 2.50 - 2.32 (63 - 58) | 2.13 - 2.01 (54 - 51) |
| | 400 | F | — | — | — | — | — | — | 6.12 - 5.62 (155 - 142) |
| | | G | — | — | — | — | — | — | 3.05 - 2.72 (77 - 69) |
| | | H | — | — | — | — | — | — | 2.68 - 2.53 (68 - 64) |

Note: All levels ±0.25" (6).

| Displacer Type | Liquid Temp. °F | Level | 1.08 - 1.12 | 1.13 - 1.17 | 1.18 - 1.27 | 1.28 - 1.30 | 1.31 - 1.39 | 1.40 - 1.50 |
|----------------|-----------------|----------------------------|----------------------------|----------------------------|----------------------------|----------------------------|----------------------------|----------------------------|
| Porcelain | 100 | F | 4.47 - 4.20 (113 - 106) | 4.90 - 4.64 (124 - 117) | 4.57 - 4.05 (116 - 102) | 3.99 - 3.89 (101 - 98) | 4.23 - 3.82 (107 - 97) | 3.77 - 3.33 (95 - 84) |
| | | G | 1.59 - 1.43 (40 - 36) | 2.16 - 1.99 (54 - 50) | 1.94 - 1.60 (49 - 40) | 1.57 - 1.50 (39 - 38) | 1.86 - 1.59 (47 - 40) | 1.56 - 1.26 (39 - 32) |
| | | H | 0.96 - 0.92 (24 - 23) | 0.92 - 0.88 (23 - 22) | 0.88 - 0.81 (22 - 20) | 0.81 - 0.80 (20 - 20) | 0.79 - 0.74 (20 - 18) | 0.74 - 0.69 (18 - 17) |
| | 200 | F | 4.66 - 4.39 (118 - 111) | 4.33 - 4.08 (109 - 103) | 4.32 - 3.81 (109 - 96) | 4.29 - 4.18 (108 - 106) | 4.13 - 3.73 (104 - 94) | 3.93 - 3.47 (99 - 88) |
| | | G | 1.79 - 1.62 (45 - 41) | 1.58 - 1.43 (40 - 36) | 1.69 - 1.36 (42 - 34) | 1.87 - 1.80 (47 - 45) | 1.76 - 1.49 (44 - 37) | 1.71 - 1.40 (43 - 35) |
| | | H | 1.48 - 1.42 (37 - 36) | 1.41 - 1.36 (35 - 34) | 1.35 - 1.25 (34 - 31) | 1.24 - 1.23 (31 - 31) | 1.22 - 1.15 (30 - 29) | 1.14 - 1.06 (28 - 26) |
| | 300 | F | 5.18 - 4.89 (131 - 124) | 4.82 - 4.56 (122 - 115) | 4.79 - 4.25 (121 - 107) | 4.73 - 4.61 (120 - 117) | 4.56 - 4.13 (115 - 104) | 4.32 - 3.84 (109 - 97) |
| | | G | 2.31 - 2.12 (58 - 53) | 2.08 - 1.91 (52 - 48) | 2.16 - 1.80 (54 - 45) | 2.31 - 2.23 (58 - 56) | 2.19 - 1.90 (55 - 48) | 2.11 - 1.78 (53 - 45) |
| | | H | 1.99 - 1.92 (50 - 48) | 1.90 - 1.84 (48 - 46) | 1.82 - 1.69 (45 - 42) | 1.68 - 1.66 (42 - 42) | 1.64 - 1.55 (41 - 39) | 1.54 - 1.43 (39 - 36) |
| | 400 | F | 5.70 - 5.39 (144 - 136) | 5.32 - 5.04 (135 - 128) | 5.26 - 4.69 (133 - 119) | 5.17 - 5.04 (131 - 128) | 4.98 - 4.53 (126 - 115) | 4.72 - 4.22 (119 - 107) |
| | | G | 2.82 - 2.62 (71 - 66) | 2.57 - 2.39 (65 - 60) | 2.63 - 2.24 (66 - 56) | 2.74 - 2.66 (69 - 67) | 2.61 - 2.30 (66 - 58) | 2.51 - 2.15 (63 - 54) |
| | | H | 2.51 - 2.42 (63 - 61) | 2.40 - 2.32 (60 - 58) | 2.30 - 2.13 (58 - 54) | 2.12 - 2.08 (53 - 52) | 2.07 - 1.95 (52 - 49) | 1.94 - 1.81 (49 - 45) |
| 500 | F | 6.22 - 5.89 (157 - 149) | 5.81 - 5.52 (147 - 140) | 5.74 - 5.13 (145 - 130) | 5.60 - 5.47 (142 - 138) | 5.41 - 4.93 (137 - 125) | 5.12 - 4.59 (130 - 116) | |
| | G | 3.34 - 3.12 (84 - 79) | 3.07 - 2.86 (77 - 72) | 3.11 - 2.68 (78 - 68) | 3.18 - 3.09 (80 - 78) | 3.04 - 2.70 (77 - 68) | 2.91 - 2.52 (73 - 64) | |
| | H | 3.03 - 2.92 (76 - 74) | 2.89 - 2.79 (73 - 70) | 2.77 - 2.57 (70 - 65) | 2.55 - 2.51 (64 - 63) | 2.50 - 2.35 (63 - 59) | 2.33 - 2.18 (59 - 55) | |

Note: All levels ±0.25" (6).

SPECIFICATIONS

MODEL B10 ACTUATION LEVELS (cont.)

INCHES (MM)

B10 STANDARD ACTUATING LEVELS AND LIQUID SPECIFIC GRAVITY WITH DISPLACER ARRANGEMENT 1 (cont.)

| Displacer Type | Liquid Temp. °F | Level | 0.50 - 0.58 | 0.59 - 0.71 | 0.72 - 0.79 | 0.80 - 0.85 | 0.86 - 1.00 | 1.01 - 1.03 |
|-----------------------------|-----------------|-------|-----------------------------|----------------------------|----------------------------|----------------------------|----------------------------|----------------------------|
| Stainless Steel and Karbate | 100 | F | 9.91 - 7.72 (251 - 196) | 9.19 - 6.62 (233 - 168) | 8.44 - 7.16 (214 - 181) | 7.66 - 6.86 (194 - 174) | 6.71 - 4.93 (170 - 125) | 4.82 - 4.61 (122 - 117) |
| | | G | 3.46 - 2.16 (86 - 54) | 3.72 - 2.08 (94 - 52) | 3.96 - 3.07 (100 - 77) | 3.63 - 3.07 (92 - 77) | 2.96 - 1.71 (75 - 43) | 1.63 - 1.48 (41 - 37) |
| | | H | 2.51 - 2.16 (63 - 54) | 2.13 - 1.77 (54 - 44) | 1.74 - 1.59 (44 - 40) | 1.57 - 1.48 (39 - 37) | 1.46 - 1.25 (37 - 31) | 1.24 - 1.22 (31 - 30) |
| | 200 | F | 10.22 - 7.98 (259 - 202) | 7.74 - 7.44 (196 - 188) | 7.50 - 6.30 (190 - 160) | 6.15 - 5.44 (156 - 138) | 6.97 - 5.15 (177 - 130) | — |
| | | G | 3.76 - 2.42 (95 - 61) | 2.27 - 1.89 (57 - 48) | 3.02 - 2.22 (76 - 56) | 2.12 - 1.64 (53 - 41) | 3.22 - 1.93 (81 - 49) | — |
| | | H | 3.67 - 3.16 (93 - 80) | 3.11 - 2.58 (78 - 65) | 2.55 - 2.32 (64 - 58) | 2.29 - 2.16 (58 - 54) | 2.13 - 1.84 (54 - 46) | — |
| | 300 | F | — | 9.68 - 7.25 (245 - 184) | 8.31 - 7.04 (211 - 178) | 6.88 - 6.12 (174 - 155) | 7.65 - 5.73 (194 - 145) | — |
| | | G | — | 4.30 - 2.70 (109 - 68) | 3.83 - 2.96 (97 - 75) | 2.84 - 2.32 (72 - 58) | 3.89 - 2.51 (98 - 63) | — |
| | | H | — | 4.03 - 3.40 (102 - 86) | 3.36 - 3.06 (85 - 77) | 3.02 - 2.84 (76 - 72) | 2.81 - 2.42 (71 - 61) | — |
| Stainless Steel | 400 | F | — | — | 9.11 - 7.77 (231 - 197) | 7.60 - 6.80 (193 - 172) | 8.32 - 6.32 (211 - 160) | — |
| | | G | — | — | 4.63 - 3.69 (117 - 93) | 3.57 - 3.01 (90 - 76) | 4.57 - 3.09 (116 - 78) | — |
| | | H | — | — | 4.16 - 3.79 (105 - 96) | 3.75 - 3.53 (95 - 89) | 3.48 - 3.00 (88 - 76) | — |
| | 500 | F | — | — | — | — | 9.00 - 6.90 (228 - 175) | — |
| | | G | — | — | — | — | 5.24 - 3.67 (133 - 93) | — |
| | | H | — | — | — | — | 4.16 - 3.58 (105 - 90) | — |

Note: All levels $\pm 0.25"$ (6).

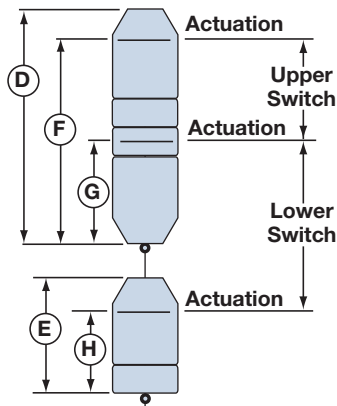

Model B10
Displacer Arrangement 1

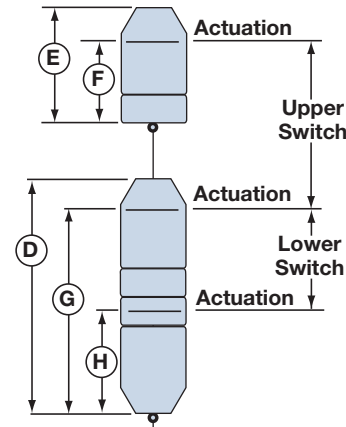

Model B10
Displacer Arrangement 2

SPECIFICATIONS

MODEL B10 ACTUATION LEVELS (cont.)

INCHES (MM)

B10 STANDARD ACTUATING LEVELS AND LIQUID SPECIFIC GRAVITY WITH DISPLACER ARRANGEMENT 2

| Displacer Type | Liquid Temp. °F | Level | 0.60 - 0.64 | 0.65 - 0.71 | 0.72 - 0.73 | 0.74 - 0.82 | 0.83 - 0.92 | 0.93 - 1.00 | 1.01 - 1.07 |
|----------------|-----------------|-------|----------------------------|----------------------------|----------------------------|----------------------------|----------------------------|----------------------------|----------------------------|
| Porcelain | 100 | F | 2.77 - 2.01 (70 - 51) | 2.63 - 1.62 (66 - 41) | 2.67 - 2.51 (67 - 63) | 2.58 - 1.42 (65 - 36) | 3.16 - 1.94 (80 - 49) | 1.82 - 1.04 (45 - 26) | 1.69 - 1.23 (42 - 31) |
| | | G | 7.27 - 6.84 (184 - 173) | 7.54 - 6.93 (191 - 176) | 7.56 - 7.46 (192 - 189) | 7.36 - 6.68 (186 - 169) | 7.64 - 6.93 (194 - 176) | 6.86 - 6.41 (174 - 162) | 5.15 - 4.89 (130 - 124) |
| | | H | 2.67 - 2.53 (67 - 64) | 3.29 - 3.05 (83 - 77) | 3.73 - 3.68 (94 - 93) | 3.64 - 3.32 (92 - 84) | 4.32 - 3.93 (109 - 99) | 3.90 - 3.65 (99 - 92) | 2.42 - 2.31 (61 - 58) |
| | 200 | F | 3.15 (80) | 2.96 - 1.93 (75 - 49) | 1.77 - 1.62 (44 - 41) | 2.64 - 1.47 (67 - 37) | 2.79 - 1.61 (70 - 40) | 2.79 - 1.94 (70 - 49) | 1.56 - 1.11 (39 - 28) |
| | | G | 7.71 (195) | 7.60 - 6.99 (193 - 177) | 6.90 - 6.81 (175 - 172) | 7.19 - 6.52 (182 - 165) | 7.28 - 6.60 (184 - 167) | 7.46 - 6.97 (189 - 177) | 5.19 - 4.92 (131 - 124) |
| | | H | 3.40 (86) | 3.36 - 3.10 (85 - 78) | 3.07 - 3.03 (77 - 76) | 3.46 - 3.16 (87 - 80) | 3.96 - 3.61 (100 - 91) | 4.50 - 4.21 (114 - 106) | 2.46 - 2.35 (62 - 59) |
| | 300 | F | — | — | — | 3.39 - 2.15 (86 - 54) | 3.47 - 2.22 (88 - 56) | 3.39 - 2.50 (86 - 63) | 2.11 - 1.63 (53 - 41) |
| | | G | — | — | — | 7.94 - 7.20 (201 - 182) | 7.95 - 7.21 (201 - 183) | 8.06 - 7.53 (204 - 191) | 5.75 - 5.45 (146 - 138) |
| | | H | — | — | — | 4.21 - 3.84 (106 - 97) | 4.63 - 4.21 (117 - 106) | 5.10 - 4.77 (129 - 121) | 3.02 - 2.87 (76 - 72) |
| | 400 | F | — | — | — | — | — | — | 2.67 - 2.15 (67 - 54) |
| | | G | — | — | — | — | — | — | 6.30 - 5.97 (160 - 151) |
| | | H | — | — | — | — | — | — | 3.57 - 3.39 (90 - 86) |

Note: All levels ±0.25" (6).

| Displacer Type | Liquid Temp. °F | Level | 1.08 - 1.12 | 1.13 - 1.17 | 1.18 - 1.27 | 1.28 - 1.30 | 1.31 - 1.39 | 1.40 - 1.50 |
|----------------|-----------------|-------|----------------------------|----------------------------|----------------------------|----------------------------|----------------------------|----------------------------|
| Porcelain | 100 | F | 1.16 - 0.89 (29 - 22) | 2.04 - 1.75 (51 - 44) | 1.68 - 1.10 (42 - 27) | 1.04 - 0.92 (26 - 23) | 2.05 - 1.56 (52 - 39) | 1.50 - 0.97 (38 - 24) |
| | | G | 4.84 - 4.68 (122 - 118) | 5.41 - 5.24 (137 - 133) | 5.20 - 4.85 (132 - 123) | 4.82 - 4.75 (122 - 120) | 5.11 - 4.84 (129 - 122) | 4.81 - 4.51 (122 - 114) |
| | | H | 2.29 - 2.22 (58 - 56) | 2.97 - 2.88 (75 - 73) | 2.86 - 2.68 (72 - 68) | 2.66 - 2.63 (67 - 66) | 3.01 - 2.85 (76 - 72) | 2.84 - 2.67 (72 - 67) |
| | 200 | F | 1.68 - 1.38 (42 - 35) | 1.31 - 1.05 (33 - 26) | 1.71 - 1.13 (43 - 28) | 1.75 - 1.62 (44 - 41) | 1.56 - 1.09 (39 - 27) | 1.53 - 1.00 (38 - 25) |
| | | G | 5.04 - 4.88 (128 - 123) | 4.84 - 4.68 (122 - 118) | 4.94 - 4.62 (125 - 117) | 5.12 - 5.05 (130 - 128) | 5.01 - 4.75 (127 - 120) | 4.96 - 4.65 (125 - 118) |
| | | H | 2.49 - 2.41 (63 - 61) | 2.39 - 2.33 (60 - 59) | 2.60 - 2.44 (66 - 61) | 2.97 - 2.93 (73 - 70) | 2.91 - 2.76 (73 - 70) | 2.99 - 2.82 (75 - 77) |
| | 300 | F | 2.19 - 1.88 (55 - 47) | 1.81 - 1.52 (45 - 38) | 2.19 - 1.57 (55 - 39) | 2.18 - 2.05 (50 - 37) | 1.98 - 1.49 (50 - 37) | 1.93 - 1.37 (49 - 34) |
| | | G | 5.56 - 5.37 (141 - 136) | 5.33 - 5.16 (135 - 131) | 5.41 - 5.06 (137 - 128) | 5.56 - 5.48 (138 - 130) | 5.44 - 5.15 (138 - 130) | 5.36 - 5.03 (136 - 127) |
| | | H | 3.01 - 2.91 (76 - 73) | 2.89 - 2.80 (73 - 71) | 3.07 - 2.88 (77 - 73) | 3.40 - 3.36 (84 - 80) | 3.33 - 3.16 (84 - 80) | 3.39 - 3.19 (86 - 81) |
| | 400 | F | 2.71 - 2.38 (68 - 60) | 2.30 - 2.00 (58 - 50) | 2.66 - 2.01 (67 - 51) | 2.62 - 2.48 (61 - 48) | 2.41 - 1.90 (61 - 48) | 2.33 - 1.74 (59 - 44) |
| | | G | 6.08 - 5.87 (154 - 149) | 5.82 - 5.64 (147 - 143) | 5.89 - 5.49 (149 - 139) | 5.99 - 5.91 (152 - 150) | 5.87 - 5.55 (149 - 140) | 5.76 - 5.40 (146 - 137) |
| | | H | 3.52 - 3.41 (89 - 86) | 3.38 - 3.28 (85 - 83) | 3.55 - 3.32 (90 - 84) | 3.84 - 3.79 (97 - 96) | 3.76 - 3.56 (95 - 90) | 3.79 - 3.56 (96 - 90) |
| | 500 | F | 3.23 - 2.88 (82 - 73) | 2.80 - 2.48 (71 - 62) | 3.13 - 2.45 (79 - 62) | 3.05 - 2.91 (77 - 73) | 2.84 - 2.30 (72 - 58) | 2.73 - 2.11 (69 - 53) |
| | | G | 6.59 - 6.37 (167 - 161) | 6.32 - 6.12 (160 - 155) | 6.36 - 5.93 (161 - 150) | 6.43 - 6.34 (163 - 161) | 6.29 - 5.95 (159 - 151) | 6.16 - 5.77 (156 - 146) |
| | | H | 4.04 - 3.91 (102 - 99) | 3.88 - 3.76 (98 - 95) | 4.02 - 3.76 (102 - 95) | 4.28 - 4.21 (108 - 106) | 4.19 - 3.97 (106 - 100) | 4.19 - 3.93 (106 - 99) |

Note: All levels ±0.25" (6).

SPECIFICATIONS

MODEL B10 ACTUATION LEVELS (cont.)

INCHES (MM)

B10 STANDARD ACTUATING LEVELS AND LIQUID SPECIFIC GRAVITY WITH DISPLACER ARRANGEMENT 2 (cont.)

| Displacer Type | Liquid Temp. °F | Level | 0.50 - 0.58 | 0.59 - 0.71 | 0.72 - 0.79 | 0.80 - 0.85 | 0.86 - 1.00 | 1.01 - 1.03 |
|-----------------------------|-----------------|-------|----------------------------|-----------------------------|-----------------------------|----------------------------|-----------------------------|----------------------------|
| Stainless Steel and Karbate | 100 | F | 3.77 - 1.60 (95 - 40) | 4.10 - 1.38 (104 - 35) | 4.43 - 2.97 (112 - 75) | 4.58 - 3.60 (24 - 91) | 3.42 - 1.26 (86 - 31) | 1.13 - 0.88 (28 - 22) |
| | | G | 9.46 - 8.16 (240 - 207) | 9.72 - 8.08 (246 - 205) | 9.96 - 9.07 (252 - 230) | 9.63 - 9.07 (244 - 230) | 8.96 - 7.71 (227 - 195) | 7.63 - 7.48 (193 - 189) |
| | | H | 3.73 - 3.21 (94 - 81) | 4.86 - 4.04 (123 - 102) | 5.97 - 5.44 (151 - 138) | 6.05 - 5.69 (153 - 144) | 5.63 - 4.84 (143 - 122) | 4.79 - 4.70 (121 - 119) |
| | 200 | F | 4.22 - 1.98 (107 - 50) | 1.74 - 1.44 (44 - 36) | 3.74 - 2.35 (94 - 59) | 2.17 - 1.33 (55 - 33) | 3.89 - 1.66 (98 - 42) | — |
| | | G | 9.76 - 8.42 (247 - 213) | 8.27 - 6.88 (210 - 174) | 9.02 - 8.22 (229 - 208) | 8.12 - 7.64 (206 - 194) | 9.22 - 7.93 (234 - 201) | — |
| | | H | 4.03 - 3.47 (102 - 88) | 3.41 - 2.84 (86 - 62) | 5.04 - 4.59 (128 - 116) | 4.53 - 4.27 (115 - 108) | 5.88 - 5.06 (149 - 128) | — |
| | 300 | F | — | 4.87 - 2.26 (123 - 57) | 4.55 - 3.08 (115 - 78) | 2.89 - 2.02 (73 - 51) | 4.56 - 2.24 (115 - 56) | — |
| | | G | — | 10.30 - 8.70 (261 - 220) | 9.83 - 8.96 (249 - 227) | 8.84 - 8.32 (224 - 211) | 9.89 - 8.51 (251 - 216) | — |
| | | H | — | 5.52 - 4.66 (140 - 118) | 5.84 - 5.33 (148 - 135) | 5.26 - 4.95 (133 - 125) | 6.56 - 5.64 (166 - 131) | — |
| Stainless Steel | 400 | F | — | — | 5.35 - 3.82 (135 - 97) | 3.62 - 2.70 (91 - 68) | 5.24 - 2.82 (133 - 71) | — |
| | | G | — | — | 10.63 - 9.69 (270 - 246) | 9.57 - 9.01 (243 - 228) | 10.57 - 9.09 (183 - 157) | — |
| | | H | — | — | 6.65 - 6.06 (168 - 153) | 5.99 - 5.63 (152 - 143) | 7.24 - 6.22 (183 - 157) | — |
| | 500 | F | — | — | — | — | 5.91 - 3.41 (150 - 86) | — |
| | | G | — | — | — | — | 11.24 - 9.67 (285 - 245) | — |
| | | H | — | — | — | — | 7.91 - 6.80 (200 - 172) | — |

Note: All levels ±0.25" (6).

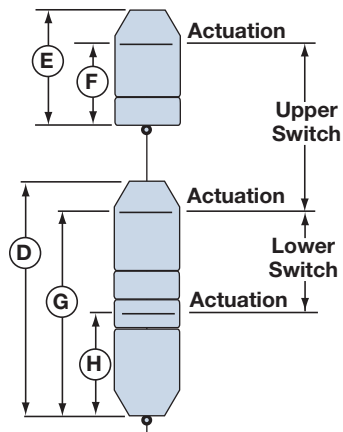

Model B10
Displacer Arrangement 2

SPECIFICATIONS

MODEL B10 ACTUATION LEVELS (cont.)

INCHES (MM)

B10 STANDARD ACTUATING LEVELS AND LIQUID SPECIFIC GRAVITY WITH DISPLACER ARRANGEMENTS 3, 4, AND 5

| Displacer Type | Liquid Temp. °F | Level | 0.60 - 0.64 | 0.65 - 0.71 | 0.72 - 0.73 | 0.74 - 0.82 | 0.83 - 0.92 | 0.93 - 1.00 | 1.01 - 1.07 |
|----------------|-----------------|-------|--------------------------|---------------------------|--------------------------|--------------------------|--------------------------|--------------------------|--------------------------|
| | | | | | | | | | |
| Porcelain | 100 | G | 2.77 - 2.01 (70 - 51) | 2.63 - 1.62 (66 - 41) | 2.67 - 2.51 (67 - 63) | 2.58 - 1.42 (65 - 36) | 3.16 - 1.94 (80 - 49) | 1.82 - 1.04 (45 - 26) | 1.69 - 1.23 (42 - 31) |
| | | H | 2.24 - 1.81 (56 - 45) | 2.51 - 1.90 (63 - 48) | 2.53 - 2.43 (64 - 61) | 2.34 - 1.66 (59 - 42) | 2.62 - 1.91 (66 - 48) | 1.84 - 1.38 (46 - 35) | 1.53 - 1.26 (38 - 32) |
| | | J | 2.01 - 1.89 (51 - 48) | 1.86 - 1.70 (47 - 43) | 1.68 - 1.65 (42 - 41) | 1.63 - 1.47 (41 - 37) | 1.45 - 1.31 (36 - 33) | 1.30 - 1.21 (33 - 30) | 1.02 - .097 (25 - 24) |
| | 200 | G | 3.15 (80) | 2.96 - 1.93 (75 - 49) | 1.77 - 1.62 (44 - 41) | 2.64 - 1.47 (67 - 37) | 2.79 - 1.61 (70 - 40) | 2.79 - 1.94 (70 - 49) | 1.56 - 1.11 (39 - 28) |
| | | H | 2.69 (68) | 2.57 - 1.96 (965 - 49) | 1.87 - 1.78 (47 - 45) | 2.16 - 1.50 (54 - 38) | 2.25 - 1.58 (57 - 40) | 2.44 - 1.94 (61 - 49) | 1.40 - 1.14 (35 - 28) |
| | | J | 2.76 (70) | 2.72 - 2.49 (69 - 63) | 2.45 - 2.42 (62 - 61) | 2.39 - 2.15 (60 - 54) | 2.13 - 1.92 (54 - 48) | 1.90 - 1.77 (48 - 44) | 1.58 - 1.49 (40 - 37) |
| | 300 | G | — | — | — | 3.39 - 2.15 (86 - 54) | 3.47 - 2.22 (88 - 56) | 3.39 - 2.50 (86 - 63) | 2.11 - 1.63 (53 - 41) |
| | | H | — | — | — | 2.92 - 2.18 (74 - 55) | 2.93 - 2.18 (74 - 55) | 3.04 - 2.50 (77 - 63) | 1.95 - 1.66 (49 - 42) |
| | | J | — | — | — | 3.14 - 2.83 (79 - 71) | 2.80 - 2.53 (71 - 64) | 2.50 - 2.32 (63 - 58) | 2.13 - 2.01 (54 - 51) |
| | 400 | G | — | — | — | — | — | — | 2.67 - 2.15 (67 - 54) |
| | | H | — | — | — | — | — | — | 2.68 - 2.34 (68 - 59) |
| | | J | — | — | — | — | — | — | 2.68 - 2.53 (68 - 64) |

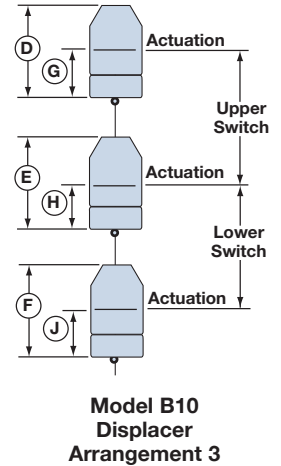

Note: All levels ±0.25" (6).

| Displacer Type | Liquid Temp. °F | Level | 1.08 - 1.12 | 1.13 - 1.17 | 1.18 - 1.27 | 1.28 - 1.30 | 1.31 - 1.39 | 1.40 - 1.50 |
|----------------|-----------------|--------------------------|--------------------------|--------------------------|--------------------------|--------------------------|--------------------------|--------------------------|
| | | | | | | | | |
| Porcelain | 100 | G | 1.16 - 0.89 (29 - 22) | 2.04 - 1.75 (51 - 44) | 1.68 - 1.10 (42 - 27) | 1.04 - 0.92 (26 - 23) | 2.05 - 1.56 (52 - 39) | 1.50 - 0.97 (38 - 24) |
| | | H | 1.22 - 1.06 (30 - 26) | 1.78 - 1.61 (45 - 40) | 1.57 - 1.23 (39 - 31) | 1.19 - 1.12 (30 - 28) | 1.49 - 1.21 (37 - 30) | 1.18 - 0.89 (29 - 22) |
| | | J | 0.96 - 0.92 (24 - 23) | 0.92 - 0.88 (23 - 22) | 0.88 - 0.81 (22 - 20) | 0.81 - 0.80 (20 - 20) | 0.79 - 0.74 (20 - 18) | 0.74 - 0.69 (18 - 17) |
| | 200 | G | 1.68 - 1.38 (42 - 35) | 1.31 - 1.05 (33 - 26) | 1.71 - 1.13 (43 - 28) | 1.75 - 1.62 (44 - 41) | 1.56 - 1.09 (39 - 27) | 1.53 - 1.00 (38 - 25) |
| | | H | 1.42 - 1.25 (36 - 31) | 1.21 - 1.06 (30 - 26) | 1.31 - 0.99 (33 - 25) | 1.50 - 1.42 (38 - 36) | 1.39 - 1.12 (35 - 28) | 1.33 - 1.03 (33 - 26) |
| | | J | 1.48 - 1.42 (37 - 36) | 1.41 - 1.36 (35 - 34) | 1.35 - 1.25 (34 - 31) | 1.24 - 1.23 (31 - 31) | 1.22 - 1.15 (30 - 29) | 1.14 - 1.06 (28 - 26) |
| | 300 | G | 2.19 - 1.88 (55 - 47) | 1.81 - 1.52 (45 - 38) | 2.19 - 1.57 (55 - 39) | 2.18 - 2.05 (50 - 37) | 1.98 - 1.49 (50 - 37) | 1.93 - 1.37 (49 - 34) |
| | | H | 1.93 - 1.75 (49 - 44) | 1.70 - 1.53 (43 - 38) | 1.79 - 1.43 (45 - 36) | 1.93 - 1.85 (49 - 46) | 1.81 - 1.52 (45 - 38) | 1.73 - 1.40 (43 - 35) |
| | | J | 1.99 - 1.92 (50 - 48) | 1.90 - 1.84 (48 - 46) | 1.82 - 1.69 (45 - 42) | 1.68 - 1.66 (42 - 42) | 1.64 - 1.55 (41 - 39) | 1.54 - 1.43 (39 - 36) |
| | 400 | G | 2.71 - 2.38 (68 - 60) | 2.30 - 2.00 (58 - 50) | 2.66 - 2.01 (67 - 51) | 2.62 - 2.48 (61 - 48) | 2.41 - 1.90 (61 - 48) | 2.33 - 1.74 (59 - 44) |
| | | H | 2.45 - 2.25 (62 - 57) | 2.20 - 2.01 (55 - 51) | 2.26 - 1.87 (57 - 47) | 2.37 - 2.28 (60 - 57) | 2.24 - 1.92 (56 - 23) | 2.13 - 1.77 (54 - 44) |
| | | J | 2.51 - 2.42 (63 - 61) | 2.40 - 2.32 (60 - 58) | 2.30 - 2.13 (58 - 54) | 2.12 - 2.08 (53 - 52) | 2.07 - 1.95 (52 - 49) | 1.94 - 1.81 (49 - 45) |
| 500 | G | 3.23 - 2.88 (82 - 73) | 2.80 - 2.48 (71 - 62) | 3.13 - 2.45 (79 - 62) | 3.05 - 2.91 (77 - 73) | 2.84 - 2.30 (72 - 58) | 2.73 - 2.11 (69 - 53) | |
| | H | 2.97 - 2.75 (75 - 69) | 2.69 - 2.49 (68 - 63) | 2.73 - 2.31 (69 - 58) | 2.80 - 2.71 (71 - 68) | 2.67 - 2.33 (67 - 59) | 2.53 - 2.15 (64 - 54) | |
| | J | 3.03 - 2.92 (76 - 74) | 2.89 - 2.79 (73 - 70) | 2.77 - 2.57 (70 - 65) | 2.55 - 2.51 (64 - 63) | 2.50 - 2.35 (63 - 59) | 2.33 - 2.18 (59 - 55) | |

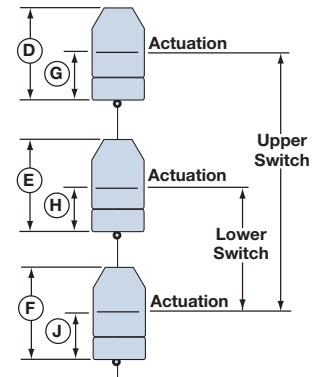

Model B10 Displacer Arrangement 4

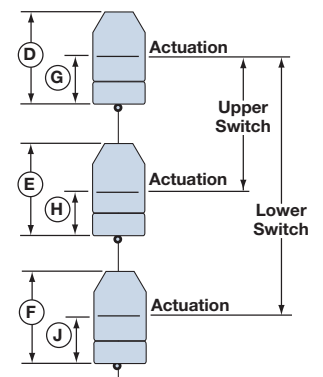

Model B10 Displacer Arrangement 5

Note: All levels ±0.25" (6).

SPECIFICATIONS

MODEL B10 ACTUATION LEVELS (cont.)

INCHES (MM)

B10 STANDARD ACTUATING LEVELS AND LIQUID SPECIFIC GRAVITY WITH DISPLACER ARRANGEMENTS 3, 4, AND 5

| Displacer Type | Liquid Temp. °F | Level | 0.50 - 0.58 | 0.59 - 0.71 | 0.72 - 0.79 | 0.80 - 0.85 | 0.86 - 1.00 | 1.01 - 1.03 |
|-----------------------------|-----------------|-------|---------------------------|---------------------------|---------------------------|--------------------------|---------------------------|--------------------------|
| Stainless Steel and Karbate | 100 | G | 3.77 - 1.60 (95 - 40) | 4.10 - 1.38 (104 - 35) | 4.43 - 2.97 (112 - 75) | 4.58 - 3.60 (24 - 91) | 3.42 - 1.26 (86 - 31) | 1.13 - 0.88 (28 - 22) |
| | | H | 3.46 - 2.16 (87 - 54) | 3.72 - 2.08 (94 - 52) | 3.96 - 3.07 (100 - 77) | 3.63 - 3.07 (92 - 77) | 2.96 - 1.71 (75 - 43) | 1.45 - 1.31 (36 - 33) |
| | | J | 2.51 - 2.16 (63 - 54) | 2.13 - 1.77 (54 - 44) | 1.74 - 1.59 (44 - 40) | 1.57 - 1.48 (39 - 37) | 1.46 - 1.25 (37 - 31) | 1.24 - 1.22 (31 - 30) |
| | 200 | G | 4.22 - 1.98 (107 - 50) | 1.74 - 1.44 (44 - 36) | 3.74 - 2.35 (94 - 59) | 2.17 - 1.33 (55 - 33) | 3.89 - 1.66 (98 - 42) | — |
| | | H | 3.76 - 2.42 (95 - 61) | 2.27 - 1.89 (57 - 48) | 3.02 - 2.22 (76 - 56) | 2.12 - 1.64 (53 - 41) | 3.22 - 1.93 (81 - 49) | — |
| | | J | 3.67 - 3.16 (93 - 80) | 3.11 - 2.58 (78 - 65) | 2.55 - 2.32 (64 - 58) | 2.29 - 2.16 (58 - 54) | 2.13 - 1.84 (54 - 46) | — |
| | 300 | G | — | 4.87 - 2.26 (123 - 57) | 4.55 - 3.08 (115 - 78) | 2.89 - 2.02 (73 - 51) | 4.56 - 2.24 (115 - 56) | — |
| | | H | — | 4.30 - 2.70 (109 - 68) | 3.83 - 2.96 (97 - 75) | 2.84 - 2.32 (72 - 58) | 3.89 - 2.51 (98 - 63) | — |
| | | J | — | 4.03 - 3.40 (102 - 86) | 3.36 - 3.06 (85 - 77) | 3.02 - 2.84 (76 - 72) | 2.81 - 2.42 (71 - 61) | — |
| Stainless Steel | 400 | G | — | — | 5.35 - 3.82 (135 - 97) | 3.62 - 2.70 (91 - 68) | 5.24 - 2.82 (133 - 71) | — |
| | | H | — | — | 4.63 - 3.69 (117 - 93) | 3.57 - 3.01 (90 - 76) | 4.57 - 3.09 (116 - 78) | — |
| | | J | — | — | 4.16 - 3.79 (105 - 96) | 3.75 - 3.53 (95 - 89) | 3.48 - 3.00 (88 - 76) | — |
| | 500 | G | — | — | — | — | 5.91 - 3.41 (150 - 86) | — |
| | | H | — | — | — | — | 5.24 - 3.67 (133 - 93) | — |
| | | J | — | — | — | — | 4.16 - 3.58 (105 - 90) | — |

Note: All levels $\pm 0.25"$ (6).

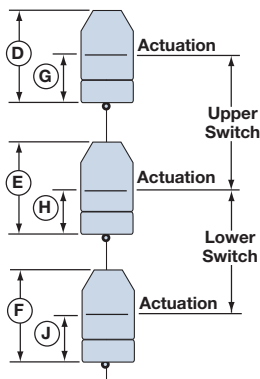

**Model B10
Displacer
Arrangement 3**

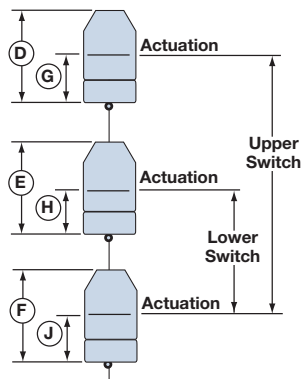

**Model B10
Displacer
Arrangement 4**

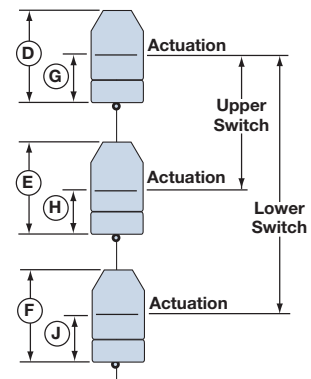

**Model B10
Displacer
Arrangement 5**

SPECIFICATIONS

MODEL B15 DIMENSIONAL DATA AND ACTUATION LEVELS*

INCHES (MM)

| Outline Dimensions | | | | |
|----------------------------|-------------------|---------------|------------------|---------------|
| Displacer Type | Threaded Mounting | | Flanged Mounting | |
| | A | B | A | B |
| Porcelain | 5.50 (139) | 243.00 (6172) | 7.50 (190) | 245.00 (6223) |
| Stainless Steel or Karbate | 5.88 (149) | 243.00 (6172) | 7.88 (200) | 245.00 (6223) |

| Displacer Type | C | D | E |
|----------------------------|-----------|-------------|------------|
| Porcelain | 2.56 (65) | 7.25 (184) | 5.02 (127) |
| Stainless Steel or Karbate | 2.50 (63) | 10.50 (266) | 6.00 (152) |

| Electrical Connections |
|------------------------------|
| TYPE 4X/7/9, Group B: 1" NPT |

B15 STANDARD ACTUATING LEVELS AND LIQUID SPECIFIC GRAVITY

| Displacer Type | Liquid Temp. °F | 0.70 | | | | 0.80 | | | |
|----------------------------|-----------------|------------|------------|------------|-----------|------------|------------|------------|-----------|
| | | F | G | H | J | F | G | H | J |
| Stainless Steel or Karbate | 100 | 9.50 (241) | 5.00 (127) | 4.90 (124) | 1.30 (33) | 7.60 (193) | 3.70 (93) | 4.30 (109) | 1.10 (27) |
| | 200 | — | — | — | — | 8.20 (208) | 4.30 (109) | 5.00 (127) | 1.80 (45) |

Note: All levels ±0.25" (6).

*See page 21 for PROOF-ER and/or floating rooftop switch dimensions.

| Displacer Type | Liquid Temp. °F | 0.95 | | | | 1.00 | | | |
|-----------------|-----------------|------------|-----------|------------|-----------|------------|-----------|------------|-----------|
| | | F | G | H | J | F | G | H | J |
| Porcelain | 100 | 5.50 (139) | 2.00 (50) | 3.70 (93) | 1.00 (25) | 5.00 (127) | 1.70 (43) | 3.50 (88) | 0.80 (20) |
| Stainless Steel | 100 | 5.50 (139) | 2.00 (50) | 3.70 (93) | 1.00 (25) | 4.90 (124) | 1.70 (43) | 3.40 (86) | 0.90 (22) |
| | 200 | 6.00 (152) | 2.70 (68) | 4.20 (106) | 1.50 (38) | 5.40 (137) | 2.20 (55) | 4.00 (101) | 1.50 (38) |
| | 300 | 6.40 (162) | 3.10 (78) | 4.70 (119) | 2.00 (50) | 5.70 (144) | 2.50 (63) | 4.40 (111) | 1.90 (48) |
| Karbate | 100 | 5.50 (139) | 2.00 (50) | 3.70 (93) | 1.00 (25) | 4.90 (124) | 1.70 (43) | 3.40 (86) | 0.90 (22) |
| | 200 | 6.00 (152) | 2.70 (68) | 4.20 (106) | 1.50 (38) | 5.40 (137) | 2.20 (55) | 4.00 (101) | 1.50 (38) |
| | 300 | 6.40 (162) | 3.10 (78) | 4.70 (119) | 2.00 (50) | 5.70 (144) | 2.50 (63) | 4.40 (111) | 1.90 (48) |

Note: All levels ±0.25" (6).

*See page 21 for PROOF-ER and/or floating rooftop switch dimensions.

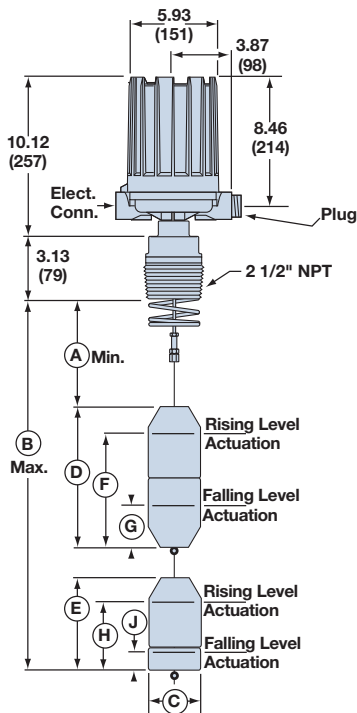

Model B15
with Threaded Mounting

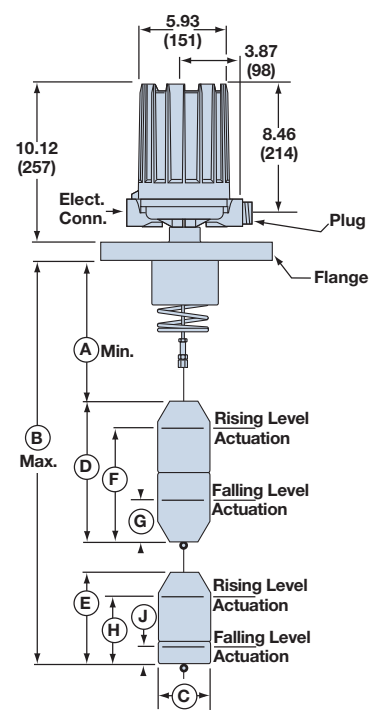

Model B15
with Flanged Mounting

SPECIFICATIONS

MODEL C10 DIMENSIONAL DATA

INCHES (MM)

MODEL C10 WITH ALL DISPLACER ARRANGEMENTS

| Outline Dimensions | | | | |
|----------------------------|-------------------|------------------|------------------|------------------|
| Displacer Type | Threaded Mounting | | Flanged Mounting | |
| | A | B | A | B |
| Porcelain | 6.38 (965) | 243.00 (6172) | 8.38 (212) | 245.00 (6223) |
| Stainless Steel or Karbate | 5.75 (146) | 243.00 (6172) | 7.75 (196) | 245.00 (6223) |

MODEL C10 WITH DISPLACER ARRANGEMENTS A, B, AND C

| Displacer Type | C | D | E | F | G |
|----------------------------|--------------|---------------|---------------|---------------|---------------|
| Porcelain | 2.56 (65) | 6.42 (163) | 5.02 (127) | 5.02 (127) | 3.62 (91) |
| Stainless Steel or Karbate | 2.50 (63) | 6.00 (152) | 6.00 (152) | 4.50 (114) | 4.50 (114) |

MODEL C10 WITH DISPLACER ARRANGEMENTS D AND F

| Displacer Type | C | D | E | F |
|----------------------------|--------------|----------------|---------------|---------------|
| Porcelain | 2.56 (65) | 14.44 (367) | 5.02 (127) | 3.62 (91) |
| Stainless Steel or Karbate | 2.50 (63) | 12.00 (304) | 4.50 (114) | 4.50 (114) |

MODEL C10 WITH DISPLACER ARRANGEMENTS E AND G

| Displacer Type | C | D | E | F |
|----------------------------|--------------|---------------|---------------|---------------|
| Porcelain | 2.56 (65) | 6.42 (153) | 5.02 (127) | 8.65 (219) |
| Stainless Steel or Karbate | 2.50 (63) | 6.00 (152) | 6.00 (152) | 9.00 (228) |

| Electrical Connections | |
|------------------------|--------|
| TYPE 4X/7/9, Group B: | 1" NPT |

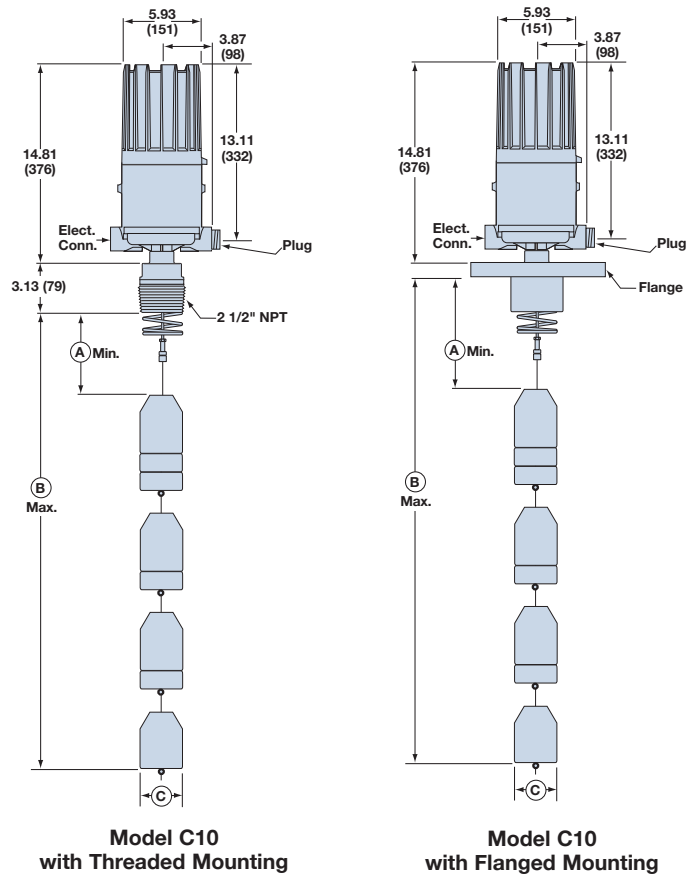

SPECIFICATIONS

MODEL C10 ACTUATION LEVELS

C10 STANDARD ACTUATING LEVELS AND LIQUID SPECIFIC GRAVITY WITH DISPLACER ARRANGEMENTS A, B, AND C

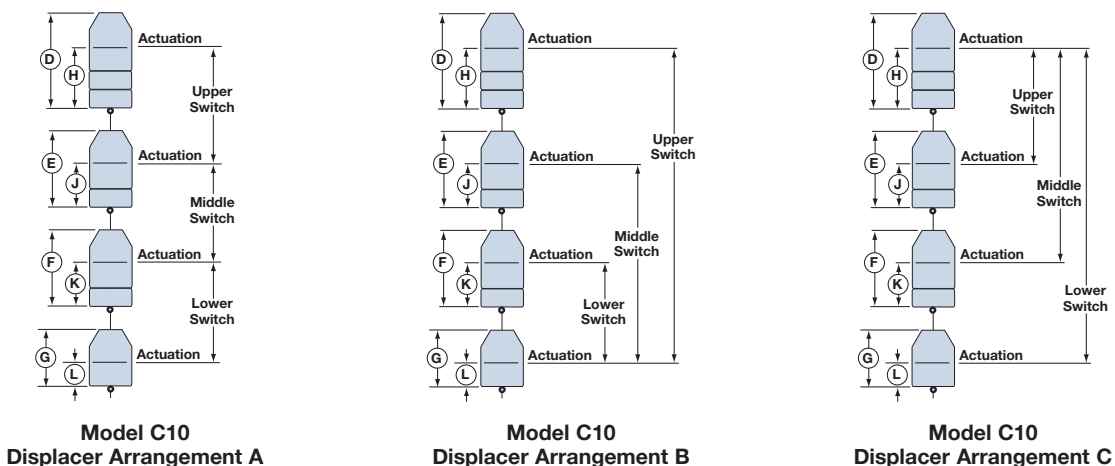

SPECIFICATIONS

MODEL C10 ACTUATION LEVELS (cont.)

C10 STANDARD ACTUATING LEVELS AND LIQUID SPECIFIC GRAVITY WITH DISPLACER ARRANGEMENTS A, B, AND C

PLEASE REFER TO
PAGE 16 FOR
DISPLACER
ARRANGEMENTS
A, B, AND C.

| Displacer Type | Liquid Temp. °F (°C) | 0.58 | | | | 0.60 | | | | 0.70 | | | | 0.80 | | | |
|----------------------------|----------------------|-----------|----------|----------|----------|----------|----------|----------|----------|-----------|----------|----------|----------|----------|----------|----------|----------|
| | | H | J | K | L | H | J | K | L | H | J | K | L | H | J | K | L |
| Porcelain | 100 (37.8) | — | — | — | — | — | — | — | — | 2.5 (64) | 2.2 (56) | 2.2 (56) | 2.0 (51) | 2.3 (58) | 2.0 (51) | 1.9 (48) | 1.7 (43) |
| | 200 (93) | — | — | — | — | — | — | — | — | — | — | — | — | — | — | — | — |
| Stainless Steel or Karbate | 100 (37.8) | 4.5 (114) | 3.7 (94) | 3.2 (81) | 2.3 (58) | 3.8 (97) | 3.2 (81) | 3.0 (76) | 2.2 (56) | 4.2 (107) | 3.8 (97) | 2.1 (53) | 1.9 (48) | 1.8 (46) | 2.2 (56) | 1.3 (33) | 1.7 (43) |
| | 200 (93) | — | — | — | — | — | — | — | — | — | — | — | — | 3.2 (81) | 2.9 (74) | 2.5 (64) | 2.3 (58) |
| | 300 (149) | — | — | — | — | — | — | — | — | — | — | — | — | — | — | — | — |

Note: All levels ±0.25" (6).

PLEASE REFER TO
PAGE 16 FOR
DISPLACER
ARRANGEMENTS
A, B, AND C.

| Displacer Type | Liquid Temp. °F (°C) | 0.90 | | | | 1.00 | | | | 1.10 | | | | 1.20 | | | |
|----------------------------|----------------------|----------|----------|----------|----------|-----------|----------|----------|----------|-----------|----------|----------|----------|----------|----------|----------|----------|
| | | H | J | K | L | H | J | K | L | H | J | K | L | H | J | K | L |
| Porcelain | 100 (37.8) | 3.0 (76) | 2.4 (61) | 2.7 (69) | 1.5 (38) | 1.4 (36) | 1.4 (36) | 2.1 (53) | 1.4 (36) | 3.0 (76) | 2.6 (66) | 2.5 (64) | 1.2 (30) | 1.7 (43) | 1.7 (43) | 2.1 (53) | 1.1 (28) |
| | 200 (93) | — | — | — | — | 3.2 (157) | 2.7 (78) | 2.8 (71) | 1.7 (43) | 1.7 (132) | 1.7 (53) | 2.3 (58) | 1.6 (40) | — | — | — | — |
| Stainless Steel or Karbate | 100 (37.8) | 3.1 (79) | 3.2 (81) | 2.5 (64) | 1.5 (38) | 1.3 (33) | 1.9 (48) | 1.8 (45) | 1.3 (33) | 3.1 (79) | 3.2 (81) | 2.5 (64) | 1.3 (33) | 1.6 (41) | 2.2 (56) | 1.9 (48) | 1.2 (30) |
| | 200 (93) | 3.6 (91) | 3.6 (91) | 1.7 (43) | 2.0 (51) | 1.7 (43) | 2.3 (58) | 1.1 (27) | 1.8 (46) | — | — | — | — | — | — | — | — |
| | 300 (149) | 3.4 (86) | 3.0 (76) | 2.4 (61) | 2.7 (69) | 1.6 (41) | 1.8 (46) | 1.7 (43) | 2.4 (61) | — | — | — | — | — | — | — | — |

Note: All levels ±0.25" (6).

C10 STANDARD ACTUATING LEVELS AND LIQUID SPECIFIC GRAVITY WITH DISPLACER ARRANGEMENTS D AND F

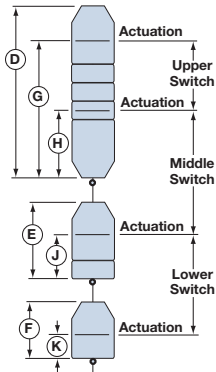

Model C10
Displacer
Arrangement D

| Displacer Type | Liquid Temp. °F | 0.58 | | | | 0.60 | | | | 0.70 | | | | 0.80 | | | |
|----------------------------|-----------------|------------|-----------|-----------|-----------|------------|-----------|-----------|-----------|------------|-----------|-----------|-----------|------------|-----------|-----------|-----------|
| | | G | H | J | K | G | H | J | K | G | H | J | K | G | H | J | K |
| Porcelain | 100 | — | — | — | — | — | — | — | — | 7.50 (190) | 2.60 (66) | 2.20 (55) | 2.00 (50) | 6.90 (175) | 2.40 (60) | 1.90 (48) | 1.70 (43) |
| Stainless Steel or Karbate | 100 | 9.90 (251) | 3.70 (93) | 3.20 (81) | 2.30 (58) | 9.20 (233) | 3.20 (81) | 3.00 (76) | 2.20 (55) | 8.90 (226) | 3.80 (96) | 2.10 (53) | 1.90 (48) | 6.70 (170) | 2.20 (55) | 1.30 (33) | 1.70 (43) |
| | 200 | — | — | — | — | — | — | — | — | — | — | — | — | 7.40 (187) | 2.90 (73) | 2.50 (63) | 2.30 (58) |

Note: All levels ±0.25" (6).

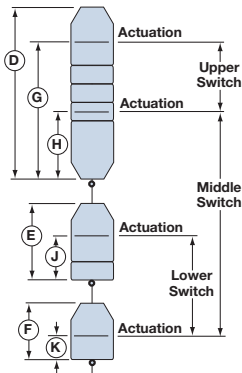

Model C10
Displacer
Arrangement F

| Displacer Type | Liquid Temp. °F | 0.90 | | | | 1.00 | | | | 1.10 | | | | 1.20 | | | |
|----------------------------|-----------------|------------|-----------|-----------|-----------|------------|-----------|-----------|-----------|------------|-----------|-----------|-----------|------------|-----------|-----------|-----------|
| | | G | H | J | K | G | H | J | K | G | H | J | K | G | H | J | K |
| Porcelain | 100 | 6.60 (167) | 2.80 (71) | 2.70 (68) | 1.50 (38) | 5.20 (132) | 1.80 (45) | 2.10 (53) | 1.40 (35) | 6.10 (154) | 3.00 (76) | 2.50 (63) | 1.20 (30) | 5.00 (127) | 2.10 (53) | 2.10 (53) | 1.10 (27) |
| | 200 | — | — | — | — | 6.20 (157) | 3.10 (78) | 2.80 (71) | 1.70 (43) | 5.20 (132) | 2.10 (53) | 2.30 (58) | 1.60 (40) | — | — | — | — |
| Stainless Steel or Karbate | 100 | 7.20 (182) | 3.20 (81) | 2.50 (63) | 1.50 (38) | 5.50 (139) | 1.90 (48) | 1.80 (45) | 1.30 (33) | 6.40 (162) | 3.20 (81) | 2.50 (63) | 1.30 (33) | 5.20 (132) | 2.20 (55) | 1.90 (48) | 1.20 (30) |
| | 200 | 7.60 (193) | 3.60 (91) | 1.70 (43) | 2.00 (50) | 5.90 (149) | 2.30 (58) | 1.10 (27) | 1.80 (45) | — | — | — | — | — | — | — | — |
| | 300 | 7.00 (177) | 3.00 (76) | 2.40 (60) | 2.70 (68) | 5.40 (137) | 1.80 (45) | 1.70 (43) | 2.40 (60) | — | — | — | — | — | — | — | — |

Note: All levels ±0.25" (6).

SPECIFICATIONS

MODEL C10 ACTUATION LEVELS (cont.)

INCHES (MM)

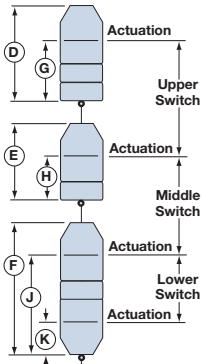

**Model C10
Displacer Arrangement E**

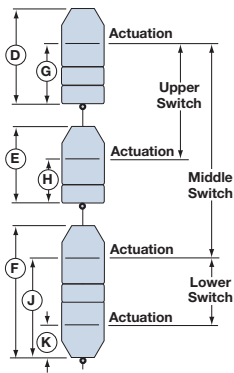

**Model C10
Displacer Arrangement G**

C10 STANDARD ACTUATING LEVELS AND LIQUID SPECIFIC GRAVITY WITH DISPLACER ARRANGEMENTS E AND G

| Displacer Type | Liquid Temp. °F | 0.58 | | | | 0.60 | | | | 0.70 | | | | 0.80 | | | |
|----------------------------|-----------------|---------------|--------------|---------------|--------------|--------------|--------------|---------------|--------------|---------------|--------------|---------------|--------------|--------------|--------------|---------------|--------------|
| | | G | H | J | K | G | H | J | K | G | H | J | K | G | H | J | K |
| Porcelain | 100 | — | — | — | — | — | — | — | — | 2.50 (63) | 2.20 (55) | 5.80 (147) | 1.90 (48) | 2.30 (58) | 2.00 (50) | 5.50 (139) | 2.10 (53) |
| Stainless Steel or Karbate | 100 | 4.50 (114) | 3.70 (93) | 7.70 (195) | 2.80 (71) | 3.80 (96) | 3.20 (81) | 7.50 (190) | 2.70 (68) | 4.20 (106) | 3.80 (96) | 6.60 (167) | 2.50 (63) | 1.80 (45) | 2.20 (55) | 5.80 (147) | 2.20 (55) |
| | 200 | — | — | — | — | — | — | — | — | — | — | — | — | 3.20 (81) | 2.90 (73) | 7.00 (177) | 3.40 (86) |

Note: All levels ±0.25" (6).

| Displacer Type | Liquid Temp. °F | 0.90 | | | | 1.00 | | | | 1.10 | | | | 1.20 | | | |
|----------------------------|-----------------|--------------|--------------|---------------|--------------|--------------|--------------|---------------|--------------|--------------|--------------|---------------|---------------|--------------|--------------|---------------|---------------|
| | | G | H | J | K | G | H | J | K | G | H | J | K | G | H | J | K |
| Porcelain | 100 | 3.00 (76) | 2.40 (60) | 6.30 (160) | 3.20 (81) | 1.40 (35) | 1.40 (35) | 5.70 (144) | 1.90 (48) | 3.00 (76) | 2.60 (66) | 6.10 (154) | 3.60 (91) | 1.70 (43) | 1.70 (43) | 5.70 (144) | 3.40 (86) |
| | 200 | — | — | — | — | 3.20 (81) | 2.70 (68) | 6.40 (162) | 3.60 (91) | 1.70 (43) | 1.70 (43) | 5.90 (149) | 3.40 (86) | — | — | — | — |
| Stainless Steel or Karbate | 100 | 3.10 (78) | 3.20 (81) | 7.00 (177) | 3.80 (96) | 1.30 (33) | 1.90 (48) | 6.30 (160) | 3.40 (86) | 3.10 (78) | 3.20 (81) | 7.00 (177) | 4.40 (111) | 1.60 (40) | 2.20 (55) | 6.40 (162) | 4.00 (101) |
| | 200 | 3.60 (91) | 3.60 (91) | 6.20 (157) | 3.00 (76) | 1.70 (43) | 2.30 (58) | 5.60 (142) | 2.70 (68) | — | — | — | — | — | — | — | — |
| | 300 | 3.40 (86) | 3.00 (76) | 6.90 (175) | 3.70 (93) | 1.60 (40) | 1.80 (45) | 6.20 (157) | 3.30 (83) | — | — | — | — | — | — | — | — |

Note: All levels ±0.25" (6).

SPECIFICATIONS

MODEL C15 ACTUATION LEVELS

INCHES (MM)

C15 STANDARD ACTUATING LEVELS AND LIQUID SPECIFIC GRAVITY

| Displacer Type | Liquid Temp. °F | 0.65 | | | | | | 0.70 | | | | | | 0.80 | | | | | |
|----------------------------|-----------------|---------------|--------------|---------------|--------------|---------------|--------------|---------------|--------------|---------------|--------------|---------------|--------------|---------------|--------------|---------------|--------------|---------------|--------------|
| | | G | H | J | K | L | M | G | H | J | K | L | M | G | H | J | K | L | M |
| Porcelain | 0 to +130 | — | — | — | — | — | — | — | — | — | — | — | — | 6.20 (157) | 1.40 (35) | 5.30 (134) | 1.00 (25) | 3.80 (96) | 0.90 (22) |
| Stainless Steel or Karbate | 0 to +130 | 7.70 (195) | 2.20 (55) | 6.10 (154) | 2.00 (50) | 4.90 (124) | 1.40 (35) | 6.70 (170) | 1.60 (40) | 5.50 (139) | 1.60 (40) | 4.60 (116) | 1.30 (33) | 6.50 (165) | 2.00 (50) | 5.20 (132) | 1.60 (40) | 4.30 (109) | 1.10 (27) |

Note: All levels ±0.25" (6).

| Displacer Type | Liquid Temp. °F | 0.90 | | | | | | 1.00 | | | | | | 1.10 | | | | | |
|----------------------------|-----------------|---------------|--------------|---------------|--------------|---------------|--------------|---------------|--------------|---------------|--------------|--------------|--------------|---------------|--------------|--------------|--------------|--------------|--------------|
| | | G | H | J | K | L | M | G | H | J | K | L | M | G | H | J | K | L | M |
| Porcelain | 0 to +130 | 6.20 (157) | 1.90 (48) | 5.00 (127) | 1.40 (35) | 3.60 (91) | 1.00 (25) | 4.60 (116) | 0.70 (17) | 4.00 (101) | 0.80 (20) | 3.30 (83) | 0.90 (22) | 4.20 (106) | 1.10 (27) | 3.80 (96) | 1.00 (25) | 3.10 (78) | 0.90 (22) |
| Stainless Steel or Karbate | 0 to +130 | 6.60 (167) | 2.60 (66) | 5.20 (132) | 1.80 (45) | 4.00 (101) | 1.20 (30) | 4.60 (116) | 1.00 (25) | 4.00 (101) | 1.00 (25) | 3.60 (91) | 1.10 (27) | — | — | — | — | — | — |

Note: All levels ±0.25" (6).

| Displacer Type | Liquid Temp. °F | 1.20 | | | | | | 1.25 | | | | | |
|----------------|-----------------|---------------|--------------|--------------|--------------|--------------|--------------|--------------|--------------|--------------|--------------|--------------|--------------|
| | | G | H | J | K | L | M | G | H | J | K | L | M |
| Porcelain | 0 to +130 | 4.50 (114) | 1.60 (40) | 3.70 (93) | 1.10 (27) | 2.90 (73) | 0.90 (22) | 3.90 (99) | 1.10 (27) | 3.30 (83) | 0.90 (22) | 2.80 (71) | 0.80 (20) |

Note: All levels ±0.25" (6).

SPECIFICATIONS

MODEL C15 DIMENSIONAL DATA AND ACTUATION LEVELS

INCHES (MM)

| OUTLINE DIMENSIONS | | | | |
|-------------------------------|-------------------|------------------|------------------|------------------|
| Displacer Type | Threaded Mounting | | Flanged Mounting | |
| | A | B | A | B |
| Porcelain | 7.75 (196) | 245.00 (6223) | 9.75 (247) | 247.00 (6273) |
| Stainless Steel or Karbate | 7.25 (184) | 244.00 (6197) | 9.25 (234) | 246.00 (6248) |

| Displacer Type | C | D | E | F |
|-------------------------------|--------------|---------------|---------------|---------------|
| Porcelain | 2.56 (65) | 7.25 (184) | 6.42 (163) | 5.02 (127) |
| Stainless Steel or Karbate | 2.50 (63) | 9.00 (228) | 7.50 (190) | 6.00 (152) |

| Electrical Connections | |
|------------------------|--------|
| TYPE 4X/7/9, Group B: | 1" NPT |

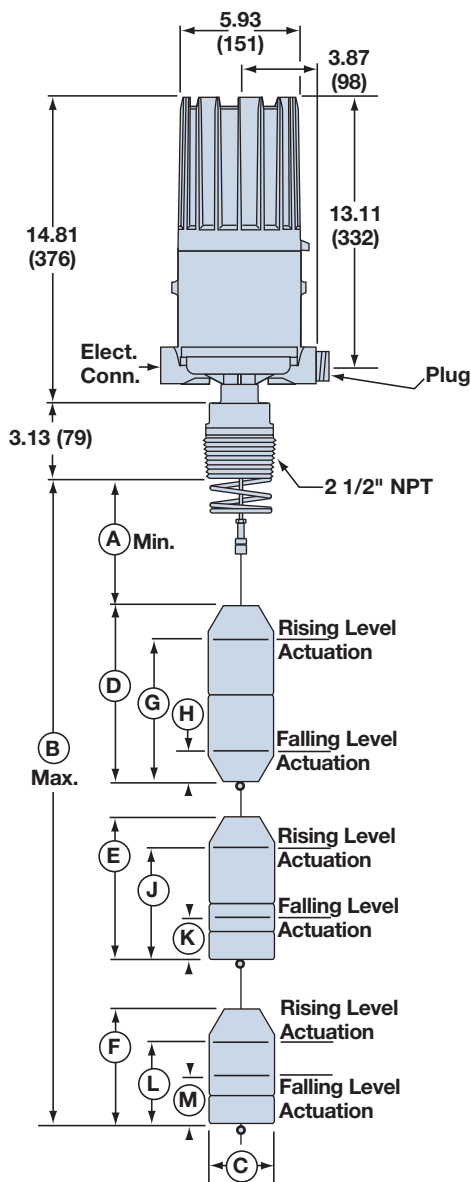

Model C15
with Threaded Mounting

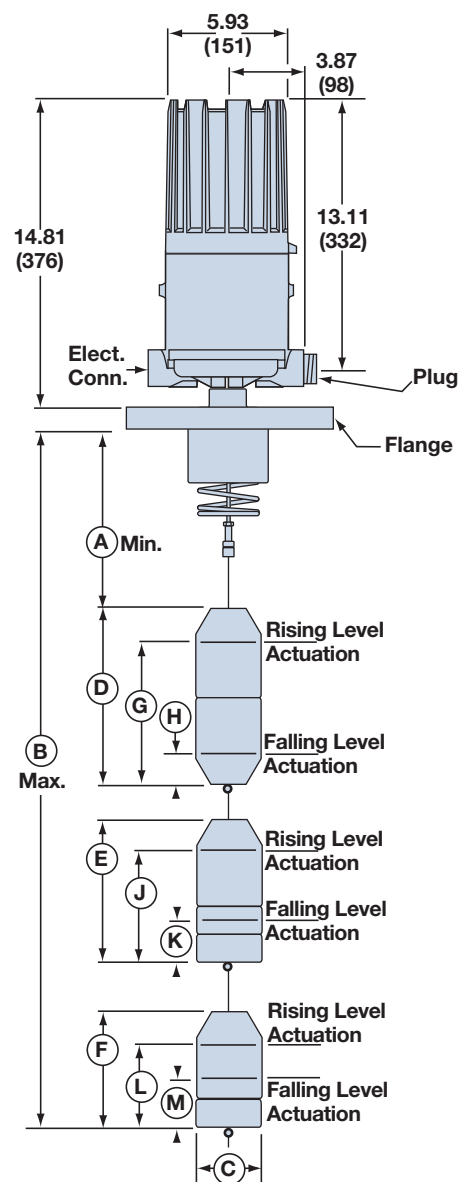

Model C15
with Flanged Mounting

MODEL NUMBER

SERIES A15 AND B15 FOR FLOATING ROOF DETECTION

PART NUMBER CODE

| Part Number Code | Function |
|------------------|-----------------------------------|
| A15 | Narrow differential, Single Stage |
| B15 | Narrow differential, Dual Stage |

MATERIALS OF CONSTRUCTION

| Code | Support Spring | Trim | E-Tube Mtg. Nut | Displacer Clamps/ Susp. Cable | Magnetic Sleeve | Process Connection |
|------|----------------|---------------|-----------------|-------------------------------|-----------------|--------------------|
| 1 | Inconel 600 | 300 Series SS | Carbon Steel | 316 SS | 400 Series SS | Carbon Steel |
| 2 | Inconel 600 | 316 SS | 316 SS | 316 SS | 316 SS | Carbon Steel |

TANK CONNECTION

| Tank Connection Code | Connection Type |
|----------------------|-------------------------------|
| E2 | 2½" NPT Threaded |
| G2 ①② | 3" 150 lb. Flat Face Flange |
| G3 ② | 3" 150 lb. Raised Face Flange |
| H2 ① | 4" 150 lb. Flat Face Flange |
| H3 | 4" 150 lb. Raised Face Flange |
| K2 ① | 6" 150 lb. Flat Face Flange |
| K3 | 6" 150 lb. Raised Face Flange |

DISPLACER MATERIAL AND PROOF-ER OPTION

| Displacer Type and Material Code | | |
|----------------------------------|------------------------|-----------------------|
| Floating Roof Only | Liquid & Floating Roof | PROOF-ER Type |
| Brass | Hollow Brass ③ | |
| P | R | Without PROOF-ER |
| Q | T | Low Pressure PROOF-ER |

MODEL SELECTION CHART

| Switch Description | Process Temp. Range °F (°C) | CONTACTS | Model A15 Codes Single Set Point | | | Model B15 Codes Dual Set Points | | |
|--|------------------------------|----------|-------------------------------------|----------------------|-----------------------------|------------------------------------|----------------------|-----------------------------|
| | | | TYPE 4X/7/9 Aluminum Enclosure | | | | | |
| | | | Cl. I, Div 1 Groups C & D | Cl. I, Div 1 Group B | ATEX Ex II 2 G EEx d IIC T6 | Cl. I, Div 1 Groups C & D | Cl. I, Div 1 Group B | ATEX Ex II 2 G EEx d IIC T6 |
| Series B Snap Switch | -40 to +250 (-40 to +121) | SPDT | BKQ | BKS | BA9 | BLB | BLK | BD9 |
| | | | DPDT | BNQ | BNS | BB9 | BOB | BOK |
| Series C Snap Switch | -40 to +450 (-40 to +232) | SPDT | CKQ | CKS | CA9 | CLB | CLK | CD9 |
| | | | DPDT | CNQ | CNS | CB9 | COB | COK |
| Series D DC Current Snap Switch | -40 to +250 (-40 to +121) | SPDT | DKQ | DKS | DA9 | DLB | DLK | DD9 |
| | | | DPDT | DNQ | DNS | DB9 | DOB | DOK |
| Series F Herm. Sealed Snap Switch | -50 to +500 (-46 to +260) | SPDT | FKQ | FKS | FA9 | FLB | FLK | FD9 |
| | | | DPDT | FNQ | FNS | FB9 | FOB | FOK |
| Series HS Herm. Sealed 5 Amp Snap Switch with Wiring Leads | -50 to +500 (-46 to +260) | SPDT | HMC | HEK | N/A | N/A | | |
| | | | DPDT | HMF | | | | |
| Series HS Herm. Sealed 5 Amp Snap Switch with Terminal Block | -50 to +500 (-46 to +260) | SPDT | HM3 | HM4 | HA9 | | | |
| | | | DPDT | HM7 | HM8 | | | |
| Series 8 Herm. Sealed Snap Switch | -50 to +500 (-46 to +260) | SPDT | 8KQ | 8KS | 8A9 | 8LB | 8LK | 8D9 |
| | | | DPDT | 8NQ | 8NS | 8B9 | 8OB | N/A |

- ① ASME B16.5 150# FF flanges are compatible with ASME B16.1 125# flanges.
- ② 3-inch process flanges available only with 7th digit R or T and with maximum nozzle schedule of 3" Sch 40.
- ③ Available on model A15 only. Suitable for process liquids with SG greater than or equal to 0.40.



SPECIFICATIONS

PROOF-ER AND FLOATING ROOFTOP DIMENSIONAL DATA

INCHES (MM)

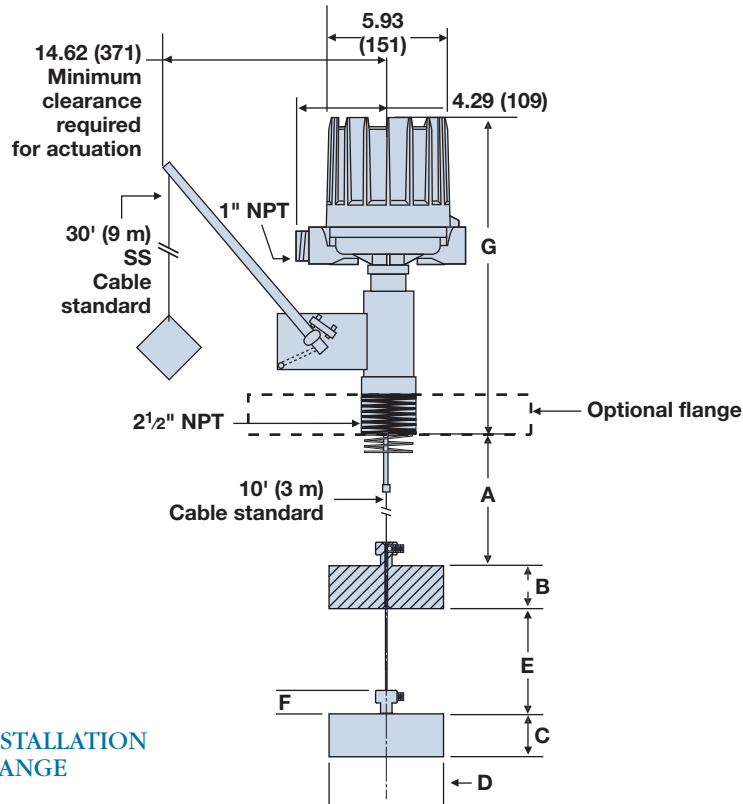

HOLLOW BRASS DISPLACER

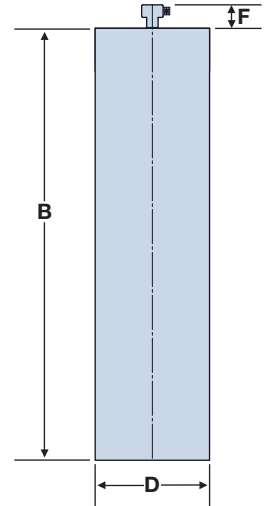

TYPICAL PROOF-ER INSTALLATION WITH VERSA FLANGE

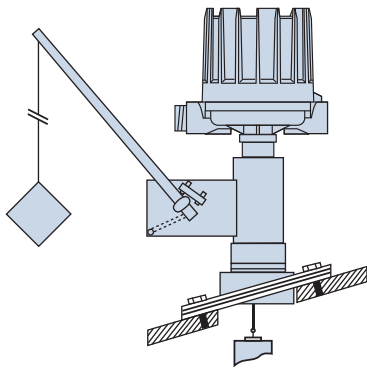

VERSA FLANGE ASSEMBLY
PART NUMBER
089-5207-001
MAX ANGLE = 15°

VERSA FLANGE BOLT CIRCLE

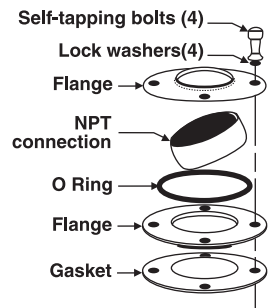
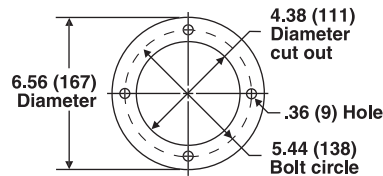

DIMENSIONAL CHART

| | | A | B | C | D | E min | F | G |
|-----|--------------|------------|------------|-----------|-----------|------------|-----------|-------------|
| A15 | Threaded | 5.62 (143) | n/a | | | | | 15.93 (405) |
| | Flanged | 7.62 (194) | n/a | | | | | 17.62 (448) |
| | SS Chunk | n/a | 2.16 (55) | n/a | 2.50 (64) | n/a | 0.82 (21) | n/a |
| | Brass Chunk | | 2.00 (51) | | 2.50 (64) | | 0.82 (21) | |
| | Hollow Brass | | 9.00 (229) | | 2.50 (64) | | 0.92 (23) | |
| B15 | Threaded | 5.88 (149) | n/a | | | | | 18.12 (460) |
| | Flanged | 7.88 (200) | n/a | | | | | 19.81 (503) |
| | SS Chunk | n/a | 2.16 (55) | 1.08 (27) | 2.50 (64) | 4.00 (102) | 0.82 (21) | n/a |
| | Brass Chunk | | 1.50 (38) | 1.00 (25) | 2.50 (64) | | 0.82 (21) | |
| | Hollow Brass | | n/a | | | | | |

MODEL NUMBER

SERIES A10 AND A15 SINGLE SWITCH MODELS

Models available for quick shipment, usually within one week after factory receipt of a complete purchase order, through the Expedite Ship Plan (ESP)

PART NUMBER CODE AND SPECIFIC GRAVITY LIMITS*

| Part Number Code | Function | Liquid Temp. | | Displacer Type | | |
|------------------|-----------------------------------|--------------|-----|----------------|-----------------|--------------|
| | | °F | °C | Porcelain | Stainless Steel | Karbate |
| A10 | Wide Differential, Single Stage | 100 | 38 | 0.60 to 1.20 | 0.60 to 1.20 | 0.60 to 1.20 |
| | | 200 | 93 | 0.70 to 1.20 | 0.70 to 1.20 | 0.70 to 1.20 |
| | | 300 | 149 | 0.80 to 1.20 | 0.80 to 1.20 | 0.80 to 1.20 |
| | | 400 | 204 | 1.00 to 1.20 | 0.90 to 1.20 | — |
| | | 500 | 260 | 1.10 to 1.20 | 1.00 to 1.20 | — |
| A15 | Narrow Differential, Single Stage | 100 | 38 | 0.60 to 2.40 | 0.40 to 1.65 | 0.40 to 1.65 |
| | | 200 | 93 | 0.62 to 2.40 | 0.40 to 1.65 | 0.45 to 1.65 |
| | | 300 | 149 | 0.65 to 2.40 | 0.50 to 1.65 | 0.50 to 1.65 |
| | | 400 | 204 | 0.70 to 2.40 | 0.55 to 1.65 | — |
| | | 500 | 260 | 0.75 to 2.40 | 0.60 to 1.65 | — |

MATERIALS OF CONSTRUCTION

| Code | Support Spring | Trim | E-Tube Mtg. Nut | Displacer Clamps/ Susp. Cable | Magnetic Sleeve | Process Connection |
|--------------------|----------------|---------------|-----------------|-------------------------------|-----------------|--------------------|
| 1 | Inconel 600 | 300 Series SS | Carbon Steel | 316 SS | 400 Series SS | Carbon Steel |
| 2 | Inconel 600 | 316 SS | 316 SS | 316 SS | 316 SS | Carbon Steel |
| 4 | | | | | | 316 SS |
| 5 | Inconel 600 | 300 Series SS | Carbon Steel | Monel | 400 Series SS | Carbon Steel |
| 6 | | | | Hastelloy | | |
| M ① NACE Const. | Inconel X750 | 316 SS | 316 SS | 316 SS | 316 SS | 316 SS |
| N ① NACE Const. | Inconel X750 | 300 Series SS | 316 SS | 316 SS | 316 SS | Carbon Steel |

TANK CONNECTION

| Tank Connection | Code |
|---------------------------------|------|
| 2½" NPT Threaded ② | E2 |
| 3" 150 lb. Flat Face Flange ③④⑤ | G2 |
| 3" 150 lb. Raised Face Flange ⑤ | G3 |
| 4" 150 lb. Flat Face Flange ③④⑤ | H2 |
| 4" 150 lb. Raised Face Flange ⑤ | H3 |
| 4" 300 lb. Raised Face Flange ⑤ | H4 |
| 6" 150 lb. Flat Face Flange ③④⑤ | K2 |
| 6" 150 lb. Raised Face Flange ⑤ | K3 |
| 6" 300 lb. Raised Face Flange ⑤ | K4 |

DISPLACER MATERIAL AND PROOF-ER OPTION

| Proof-er** Type | Displacer Material | | | Floating Roof Weight ④ | Liquid & Floating Roof Displacer |
|-------------------|--------------------|--------|---------|------------------------|----------------------------------|
| | Porcelain | 316 SS | Karbate | Brass | Hollow Brass ③ |
| Without Proof-er | A | B | C | P ③ | R ③ |
| Low Pressure ② | D ③ | E ③ | F ③ | Q ③ | T ③ |
| Medium Pressure ② | G ③ | H ③ | J ③ | — | — |

* Specific gravity limits do not apply to floating roof top units not to be used in liquid.

** Proof-er option constructed of carbon steel material.

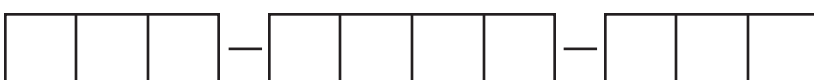

MODEL NUMBER

SERIES A10 AND A15 SINGLE SWITCH MODELS (cont.)

ELECTRIC SWITCH MECHANISM AND ENCLOSURE ⑥

| Switch Description | Max. ^⑦ Process Temp. °F (°C) | One Set Point | A10 Codes | | | A15 Codes | | |
|--|---|---------------|---------------------------------------|--------------------------|------|-------------------------------|--------------------------|------|
| | | | Aluminum Polymer Coated NEMA 4X/7/9 ⑧ | | | | | |
| | | | Class I, Div. 1, Groups C & D | Class I, Div. 1, Group B | ATEX | Class I, Div. 1, Groups C & D | Class I, Div. 1, Group B | ATEX |
| Series B Snap Switch | 250 (121) | SPDT | BKB | BKK | BC9 | BKQ | BKS | BA9 |
| | | DPDT | BNB | BNK | BF9 | BNQ | BNS | BB9 |
| Series C Snap Switch | 450 (232) | SPDT | CKB | CKK | CC9 | CKQ | CKS | CA9 |
| | | DPDT | CNB | CNK | CF9 | CNQ | CNS | CB9 |
| Series D Snap Switch For DC Current Applications | 250 (121) | SPDT | DKB | DKK | DC9 | DKQ | DKS | DA9 |
| | | DPDT | DNB | DNK | DF9 | DNQ | DNS | DB9 |
| Series F Hermetically Sealed Snap Switch | 500 (260) | SPDT | FKB | FKK | FC9 | FKQ | FKS | FA9 |
| | | DPDT | FNB | FNK | FF9 | FNQ | FNS | FB9 |
| Series HS Hermetically Sealed Snap Switch w/Wiring Leads | 500 ⑨ (260) | SPDT | HMJ | HMK | — | HMC | HEK ⑩ | — |
| | | DPDT | HMS | HMT | — | HMF | HET ⑩ | — |
| Series HS Hermetically Sealed Snap Switch w/Terminal Block | 500 ⑨ (260) | SPDT | HM3 | HM4 | HA9 | HM3 ⑪ | HM4 ⑪ | HA9 |
| | | DPDT | HM7 | HM8 | HB9 | HM7 ⑪ | HM8 ⑪ | HB9 |
| Series 8 Hermetically Sealed Snap Switch | 500 (260) | SPDT | 8KB | 8KK | 8C9 | 8KQ | 8KS | 8A9 |
| | | DPDT | 8NB | 8NK | 8F9 | 8NQ | 8NS | 8B9 |

PNEUMATIC SWITCH MECHANISM AND ENCLOSURE

| Switch Description | Maximum Supply Pressure | | Maximum Process Temperature ⑦ | | Bleed Orifice Diameter | | A10 Codes | A15 Codes |
|--------------------------------------|-------------------------|-----|-------------------------------|-----|------------------------|-----|-----------|-----------|
| | psig | bar | °F | °C | Inches | mm | NEMA 1 | NEMA 1 |
| Series J Bleed Type Pneumatic Switch | 100 | 7 | 400 | 204 | .063 | 1.6 | JGF | JDE |
| | 60 | 4 | 400 | 204 | .094 | 2.3 | JHF | JEE |
| Series K Non-Bleed Pneumatic Switch | 100 | 7 | 400 | 204 | — | — | KOF | KOE |

- ① Not available with displacer material and proof-er option codes D, E, F, G, H, J, P, Q, R or T.
- ② Pressure/temperature ratings on page 4. Flanges are ASME type.
- ③ Not available with material of construction codes M and N.
- ④ Not available with material of construction code 4.
- ⑤ 316 SS flange is provided with material of construction code 4 and M.
- ⑥ Consult factory for NEMA 4X/7/9 cast iron housings.
- ⑦ Process temperature based on +100 °F (+38 °C) ambient.
- ⑧ Uncontrolled housing heater or drain available in NEMA 4X/7/9 enclosures. Consult factory for standard part numbers.

- ⑨ On steam applications, temperature down rated to +400 °F (+204 °C) process at +100 °F (+38 °C) ambient. Available with a 6" tall cover only.
- ⑩ CSA approval does not apply to these switch designations.
- ⑪ Available with a 6" tall cover only.
- ⑫ ASME B16.5 150# FF flanges are compatible with ASME B16.1 125# flanges.
- ⑬ Use on model A15 only. Minimum SG = 0.40@ +100 °F (+38 °C).
- ⑭ Model A15 only.



MODEL NUMBER

SERIES B10 AND B15 DUAL SWITCH MODELS

Models available for quick shipment, usually within one week after factory receipt of a complete purchase order, through the Expedite Ship Plan (ESP)

Note: Each B10 instrument is factory calibrated to operate on a given specific gravity within the minimum and maximum values listed.

PART NUMBER CODE AND SPECIFIC GRAVITY LIMITS *

| Part Number Code | Function | Liquid Temp. | | Displacer Type | | |
|------------------|---------------------------------|--------------|-----|----------------|-----------------|--------------|
| | | °F | °C | Porcelain | Stainless Steel | Karbate |
| B10† | Wide Differential, Dual Stage | 100 | 38 | 0.60 to 1.20 | 0.50 to 1.00 | 0.50 to 1.00 |
| | | 200 | 93 | 0.64 to 1.50 | 0.50 to 1.00 | 0.50 to 1.00 |
| | | 300 | 149 | 0.80 to 1.50 | 0.60 to 1.00 | 0.60 to 1.00 |
| | | 400 | 204 | 1.00 to 1.50 | 0.72 to 1.00 | — |
| | | 500 | 260 | 1.10 to 1.50 | 0.84 to 1.00 | — |
| B15 | Narrow Differential, Dual Stage | 100 | 38 | 0.95 to 1.20 | 0.70 to 1.20 | 0.70 to 1.20 |
| | | 200 | 93 | 1.10 to 1.20 | 0.80 to 1.20 | 0.80 to 1.20 |
| | | 300 | 149 | — | 0.90 to 1.20 | 0.90 to 1.20 |
| | | 400 | 204 | — | 1.00 to 1.20 | — |
| | | 500 | 260 | — | 1.04 to 1.20 | — |

† When ordering B10 units, an operating sequence and operating specific gravity must be provided.

MATERIALS OF CONSTRUCTION

| Code | Support Spring | Trim | E-Tube Mtg. Nut | Displacer Clamps/ Susp. Cable | Magnetic Sleeve | Process Connection |
|-------------------------------|----------------|---------------|-----------------|-------------------------------|-----------------|--------------------|
| 1 | Inconel 600 | 300 Series SS | Carbon Steel | 316 SS | 400 Series SS | Carbon Steel |
| 2 | Inconel 600 | 316 SS | 316 SS | 316 SS | 316 SS | Carbon Steel |
| 4 | | | | | | 316 SS |
| 5 | Inconel 600 | 300 Series SS | Carbon Steel | Monel | 400 Series SS | Carbon Steel |
| 6 | | | | Hastelloy | | |
| M ^① NACE Const. | Inconel X750 | 316 SS | 316 SS | 316 SS | 316 SS | 316 SS |
| N ^① NACE Const. | Inconel X750 | 300 Series SS | 316 SS | 316 SS | 316 SS | Carbon Steel |

TANK CONSTRUCTION

| Tank Connection | Code |
|---------------------------------|------|
| 2½" NPT Threaded ② | E2 |
| 3" 150 lb. Flat Face Flange ③④⑩ | G2 |
| 3" 150 lb. Raised Face Flange ⑤ | G3 |
| 4" 150 lb. Flat Face Flange ③⑤⑩ | H2 |
| 4" 150 lb. Raised Face Flange ⑤ | H3 |
| 4" 300 lb. Raised Face Flange ⑤ | H4 |
| 6" 150 lb. Flat Face Flange ③④⑩ | K2 |
| 6" 150 lb. Raised Face Flange ⑤ | K3 |
| 6" 300 lb. Raised Face Flange ⑤ | K4 |

DISPLACER MATERIAL AND PROOF-ER OPTION

| Proof-er** Type | Displacer Material | | | Floating Roof Weight Mat'l Model B15 Only |
|------------------|--------------------|--------|---------|---|
| | Porcelain | 316 SS | Karbate | Brass |
| Without Proof-er | A | B | C | P ③ |
| Low Pressure ② | D ③ | E ③ | F ③ | Q ③ |

* Specific gravity limits do not apply to floating roof top units not to be used in liquid.

** Proof-er option constructed of carbon steel material.

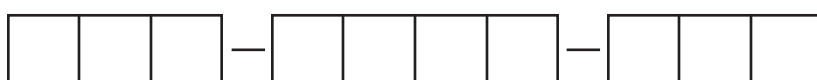

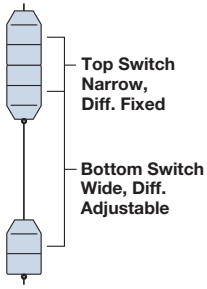

**PLUS ALARM
ARRANGEMENT NO. 1 - FILL WITH
HIGH LEVEL ALARM**

The bottom switch starts the drain cycle when the level reaches the upper displacer. The drain cycle stops when the level falls to the bottom displacer. If level rises above the “drain start” level, the top switch will activate an alarm.

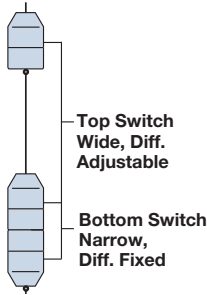

**PLUS ALARM
ARRANGEMENT NO. 2 - DRAIN
WITH LOW LEVEL ALARM**

The top switch starts the fill cycle when level drops to the lower displacer. The fill cycle stops when level rises to the top displacer. If level falls below the “fill start,” the bottom switch will activate an alarm.

**CONTROL OF TWO PUMPS OF DIFFERENT CAPACITY
ARRANGEMENT NO. 3 - TWO SWITCH, WIDE
DIFFERENTIAL OR DRAIN**

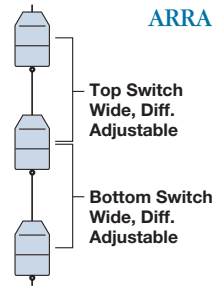

The top switch cycles with level between the top and middle displacer. The bottom switch cycles with level between the middle and bottom displacer.

**CONTROL OF TWO PUMPS - DRAIN
ARRANGEMENT NO. 4**

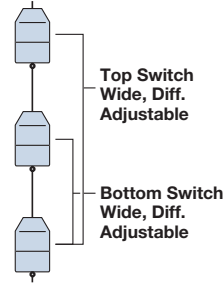

In this sequence No. 1 pump starts as the level rises to the middle displacer. Should the level continue to rise to the upper displacer, No. 2 pump is actuated. Both pumps operate until the level is dropped to the lower displacer.

**CONTROL OF TWO PUMPS - FILL
ARRANGEMENT NO. 5**

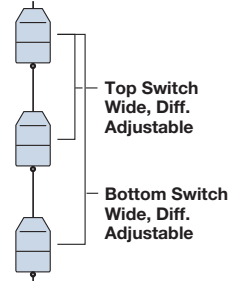

The pumping sequence of Arrangement No. 4 can be reversed for a pump “fill” application.

ELECTRIC SWITCH MECHANISM AND ENCLOSURE ⑦

| Switch Description ⑦ | Max. ⑧ Process Temp. °F (°C) | Two Set Points | Switch Enclosure | | |
|---|------------------------------------|-------------------|----------------------------------|-----------------------------|------------------------------------|
| | | | NEMA 4X/7/9 ⑨ | | |
| | | | Class I, Div. 1, Groups C & D | Class I, Div. 1, Group B | ATEX Ex II, 2G EEEx d IIC T6 |
| Series B Snap Switch | 250 (121) | SPDT | BLB | BLK | BD9 |
| | | DPDT | BOB | BOK | BG9 |
| Series C Snap Switch | 450 (232) | SPDT | CLB | CLK | CD9 |
| | | DPDT | COB | COK | CG9 |
| Series D Snap Switch For DC Current Applications | 250 (121) | SPDT | DLB | DLK | DD9 |
| | | DPDT | DOB | DOK | DG9 |
| Series F Hermetically Sealed Snap Switch | 500 (260) | SPDT | FLB | FLK | FD9 |
| | | DPDT | FOB | FOK | FG9 |
| Series 8 Hermetically Sealed Snap Switch | 500 (260) | SPDT | 8LB | 8LK | 8D9 |
| | | DPDT | 8OB | N/A | 8G9 |

- ① Not available with displacer material and proof-er option codes D, E, F, P and Q.
- ② Pressure/temperature ratings on page 4. Flanges are ASME type.
- ③ Not available with material of construction codes M and N.
- ④ Not available with material of construction code 4.
- ⑤ 316 SS flange is provided with material of construction code 4 and M.
- ⑥ Consult factory for NEMA 4X/7/9 cast iron housings.

- ⑦ Pneumatic switch mechanisms and enclosures are unavailable for Models B10 and B15 switches.
- ⑧ Process temperature based on +100 °F (+38 °C) ambient.
- ⑨ Uncontrolled housing heater or drain available in NEMA 4X/7/9 enclosures. Consult factory for standard part numbers.
- ⑩ ASME B16.5 150# FF flanges are compatible with ASME B16.1 125# flanges.

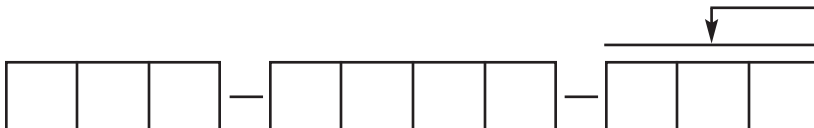

MODEL NUMBER

SERIES C10 AND C15 TRI-SWITCH MODELS

Note: Each C10 and C15 instrument is factory calibrated to operate for a given specific gravity within the minimum and maximum values listed.

PART NUMBER CODE AND SPECIFIC GRAVITY LIMITS

| Part Number Code | Function | Liquid Temp. | | Displacer Type | | |
|------------------|---------------------------------|--------------|-----|----------------|-----------------|--------------|
| | | °F | °C | Porcelain | Stainless Steel | Karbate |
| C10† | Wide Differential, 3 switches | 100 | 38 | 0.65 to 1.20 | 0.58 to 1.20 | 0.58 to 1.20 |
| | | 200 | 93 | 0.95 to 1.10 | 0.76 to 1.00 | 0.76 to 1.00 |
| | | 300 | 149 | — | 0.820 to 1.00 | 0.82 to 1.00 |
| C15†† | Narrow Differential, 3 switches | 130 | 54 | 0.80 to 1.25 | 0.65 to 1.00 | 0.65 to 1.00 |

† When ordering C10 units, an operating sequence and operating specific gravity must be provided.

†† When ordering C15 units, an operating specific gravity must be provided.

MATERIALS OF CONSTRUCTION

| Code | Support Spring | Trim | E-Tube Mtg. Nut | Displacer Clamps/ Susp. Cable | Magnetic Sleeve | Process Connection |
|------------------|----------------|---------------|-----------------|-------------------------------|-----------------|--------------------|
| 1 | Inconel 600 | 300 Series SS | Carbon Steel | 316 SS | 400 Series SS | Carbon Steel |
| 2 | Inconel 600 | 316 SS | 316 SS | 316 SS | 316 SS | Carbon Steel |
| 4 | | | | | | 316 SS |
| 5 | Inconel 600 | 300 Series SS | Carbon Steel | Monel | 400 Series SS | Carbon Steel |
| 6 | | | | Hastelloy | | |
| M NACE Const. | Inconel X750 | 316 SS | 316 SS | 316 SS | 316 SS | 316 SS |
| N NACE Const. | Inconel X750 | 300 Series SS | 316 SS | 316 SS | 316 SS | Carbon Steel |

TANK CONNECTION AND DISPLACERS

| Tank Connection ^① | Displacer Material | | |
|--|--------------------|--------|---------|
| | Porcelain | 316 SS | Karbate |
| 2½" NPT Threaded | E2A | E2B | E2C |
| 3" 150 lb. Flat Face Flange ^{②⑥} | G2A | G2B | G2C |
| 3" 150 lb. Raised Face Flange ^③ | G3A | G3B | G3C |
| 4" 150 lb. Flat Face Flange ^{②⑥} | H2A | H2B | H2C |
| 4" 150 lb. Raised Face Flange ^③ | H3A | H3B | H3C |
| 4" 300 lb. Raised Face Flange | H4A | H4B | H4C |
| 6" 150 lb. Flat Face Flange ^{②⑥} | K2A | K2B | K2C |
| 6" 150 lb. Raised Face Flange ^③ | K3A | K3B | K3C |
| 6" 300 lb. Raised Face Flange ^③ | K4A | K4B | K4C |

ELECTRIC SWITCH MECHANISM AND ENCLOSURE ^④

| Switch Description | Process ^⑤ Temp. Range °F (°C) | Three Set Points | Switch Enclosure | |
|-------------------------|--|---------------------|---|-----------------------------|
| | | | TYPE 4X/7/9 Aluminum Enclosure ^⑦ | |
| | | | Class I, Div. 1, Groups C & D | Class I, Div. 1, Group B |
| Series O Snap Switch | -40 to +300 (-40 to +149) | SPDT | OMB | OMN |
| | | DPDT | OKB | OKN |
| Series Q Snap Switch | -40 to +250 (-40 to +121) | SPDT | QMB | QMN |
| | | DPDT | QKB | QKN |

- ① Pressure/temperature ratings on page 4. Flanges are ASME type.
- ② Not available with material of construction codes M, N and 4.
- ③ 316 SS flange is provided with material of construction code 4 and M.
- ④ Pneumatic switch mechanisms and enclosures are unavailable for Series C10 and C15 switches.
- ⑤ Process temperature based on +100 °F (+38 °C) ambient.
- ⑥ ASME B16.5 150# FF flanges are compatible with ASME B16.1 125# flanges.
- ⑦ Consult factory for TYPE 4X/7/9 cast iron housings.



SPECIFICATIONS

MODEL C10 DISPLACER ARRANGEMENTS

INCHES (MM)

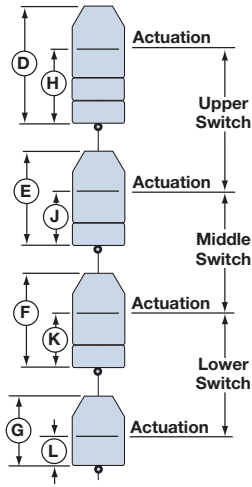

**Model C10
Displacer Arrangement A**

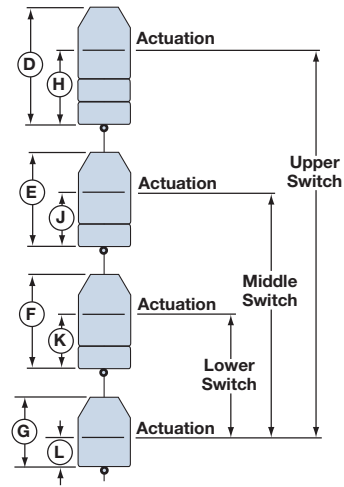

**Model C10
Displacer Arrangement B**

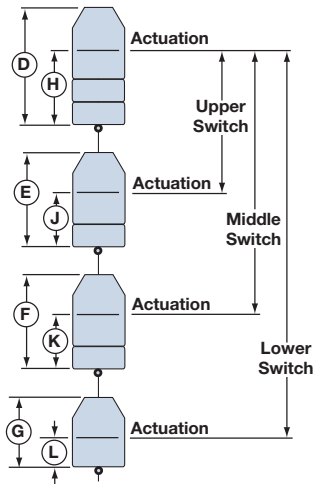

**Model C10
Displacer Arrangement C**

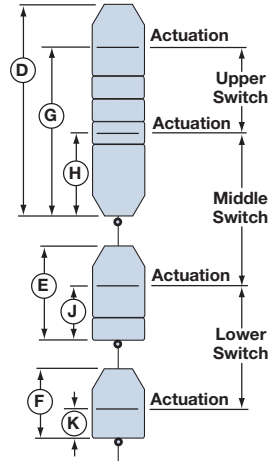

**Model C10
Displacer Arrangement D**

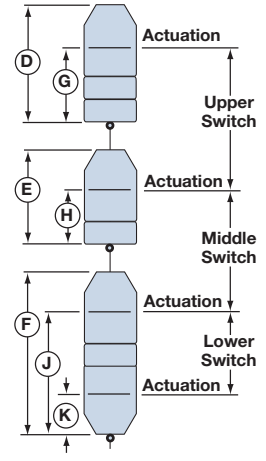

**Model C10
Displacer Arrangement E**

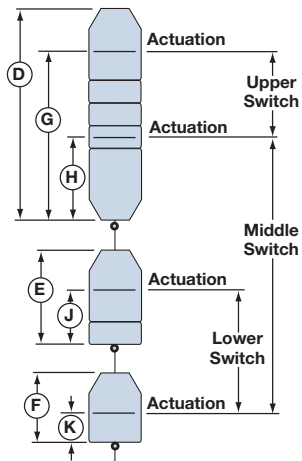

**Model C10
Displacer Arrangement F**

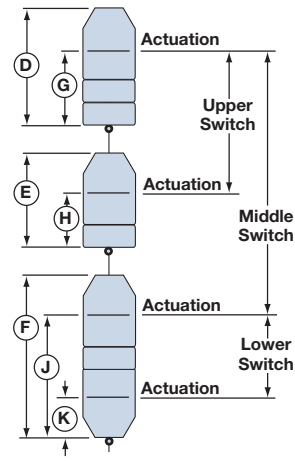

**Model C10
Displacer Arrangement G**

QUALITY



The quality assurance system in place at Magnetrol guarantees the highest level of quality throughout the company. Magnetrol is committed to providing full customer satisfaction both in quality products and quality service.

The Magnetrol quality assurance system is registered to ISO 9001 affirming its commitment to known international quality standards providing the strongest assurance of product/service quality available.

ESP

Expedite **S**hip **P**lan

Several Displacer Type Liquid Level Switches are available for quick shipment, usually within one week after factory receipt of a purchase order, through the Expedite Ship Plan (ESP).

Models covered by ESP service are conveniently color coded in the selection data charts.

To take advantage of ESP, simply match the color coded model number codes (standard dimensions apply).

ESP service may not apply to orders of ten units or more. Contact your local representative for lead times on larger volume orders, as well as other products and options.

WARRANTY



All Magnetrol mechanical level and flow controls are warranted free of defects in materials or workmanship for three full years from the date of original factory shipment.

If returned within the warranty period; and, upon factory inspection of the control, the cause of the claim is determined to be covered under the warranty; then, Magnetrol will repair

or replace the control at no cost to the purchaser (or owner) other than transportation.

Magnetrol shall not be liable for misapplication, labor claims, direct or consequential damage or expense arising from the installation or use of equipment. There are no other warranties expressed or implied, except special written warranties covering some Magnetrol products.

For additional information, see Instruction Manual, 45-610.



magnetrol.com

Copyright © 2022 AMETEK Magnetrol USA, LLC

Performance specifications are effective with date of issue and are subject to change without notice.

BULLETIN: 45-115.30

EFFECTIVE: September 2019

SUPERSEDES: February 2018