



MAGNETROL®

AMETEK®

**LEVEL MEASUREMENT
SOLUTIONS**

Thermatel® Model TD1/TD2 Thermal Dispersion Flow/Level/Interface Switch

DESCRIPTION

Thermatel® Model TD1 and TD2 Thermal Dispersion flow/level/interface switches provide continuous diagnostics with fault indication, temperature compensation, narrow hysteresis and fast response time.

TD1 is a basic switch with 24 VDC power and an 8-amp DPDT relay. The TD2 adds LED indication through a glass window, ability to electrically measure the set point, mA output for diagnostics and trending, optional hermetically sealed relay, plus time delay. A universal AC power supply simplifies installation.

Thermatel probes are available in 316 Stainless Steel, Hastelloy® C, or Monel® with all welded construction.

FEATURES

- Temperature compensated to provide repeatable alarm under varying process temperatures
- Continuous diagnostics detect sensor fault
- Non-linear mA output signal can be used for trending, diagnostics and repeatable flow/level indication (TD2)
- Detects minimum flow or presence/absence of flow
- Easy/fast calibration
- Excellent low flow sensitivity
- Optional hot tap available (see bulletin 41-103)
- NACE construction available
- Process temperatures from -100 to +400 °F (-73 to +204 °C)—High temp. version to +850 °F (+454 °C)



Model TD2
with spherical probe



Model TD1
with twin-tip probe



Model TD2
with low flow body

TECHNOLOGY

The Thermatel TD1 and TD2 switches utilize the proven thermal dispersion technology. The sensor consists of two RTD elements. One is the reference and the second is heated to a temperature above the process temperature. The electronics detect the temperature difference between the two elements. The temperature difference is greatest in air, then decreases when cooling occurs due to a change in media. An increase in the flow rate further decreases the temperature difference.

The set point is adjusted for the switch to alarm at the desired temperature difference. Once the set point is reached, the relay will change state.

ADVANCED FEATURES - TD1 & TD2

TEMPERATURE COMPENSATION

No Temperature Compensation

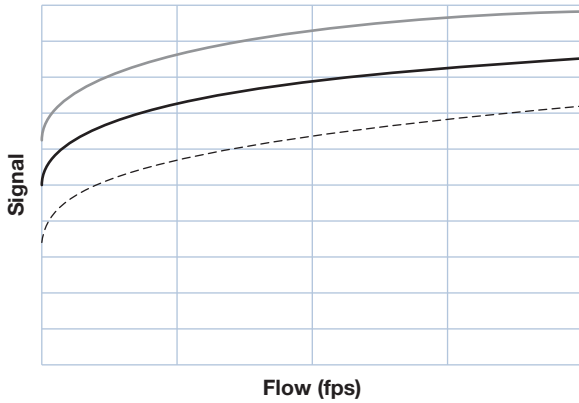

With Temperature Compensation

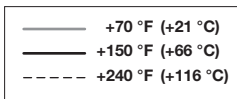
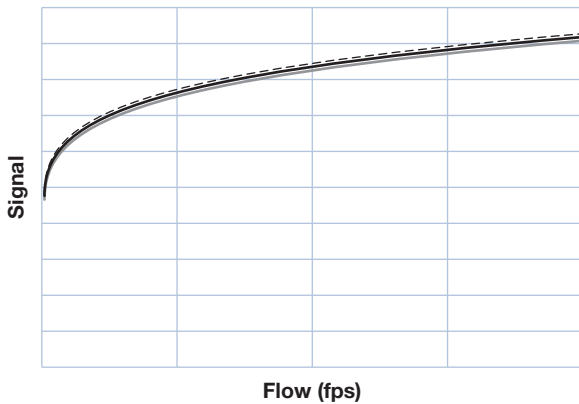

FACTORY CALIBRATION

The Thermatel flow switch can be ordered factory calibrated to alarm at a specified flow rate. A complete calibration curve can also be provided for the TD2. Using this curve the user can determine the desired set point. Consult factory for calibration options.

HOT TAP

Hot tap retractable probe assemblies for Thermatel probes are available. See Bulletin 41-103.

FAULT DETECTION

The TD1/TD2 is equipped with advanced diagnostics which continuously monitor the signal from the sensor and indicate if the signal has gone out of range. In the event of a fault, the alarm relay will de-energize and the red LED will blink. In the TD2 the mA output will change to 3.6 mA (Low Level Fail-safe) or 22 mA (High Level Fail-safe) to indicate a fault.

ADVANCED FEATURES - TD2 ONLY

Current (mA) output

The TD2 has a mA output signal can be used for diagnostics, fault detection and trending. While this mA signal is not scalable by the user, it can provide important process information. The mA signal will increase with the sensor cooling – mA will be greater in a wet condition than in a dry condition and will further increase as the flow rate increases.

The mA output can also be used for fault detection. In the event of a fault, the mA output will follow NAMUR NE 43 and go to less than 3.6 mA for Low Level Fail-safe and greater than 22 mA for High Level Fail-safe selection. Due to ATEX requirements the mA output is not available on units for Zone 0 service.

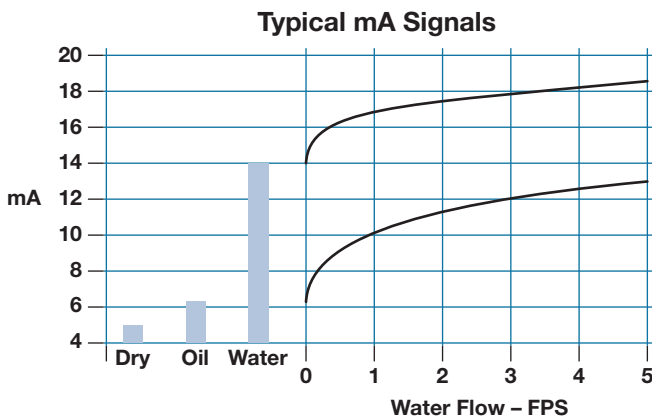

Measure the set point

With the TD2 the user can obtain an electrical measurement of the set point. This permits the user to periodically check the calibration point and verify that the set point has not changed. Due to ATEX requirements, this feature is not available on units for Zone 0 service.

Remote Electronics

The TD2 can be provided with remote electronics with up to 500 feet (150 meters) separation between the probe and electronics.

Hermetically sealed relay

The TD2 provides an optional hermetically sealed relay for the most demanding applications.



Model TD2 with Window

APPLICATIONS

Thermatel has demonstrated reliable performance as a flow or level switch. For use as a flow switch, Thermatel can be used to detect either a high flow or a low flow condition for both gases and liquids. As a level switch, Thermatel can be used to detect difference in thermal conductivity of various media. This includes interface detection between media such as liquid/foam, and oil/water.

LEVEL SWITCH

Level or Interface can be detected due to differences in thermal conductivity. High or low level alarm applications may be installed either vertically or horizontally.

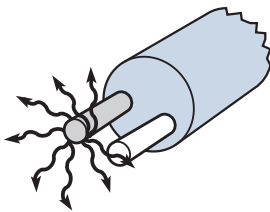

Low Level

In the absence of media, the self-heated sensor tip creates a temperature difference between the two sensors.

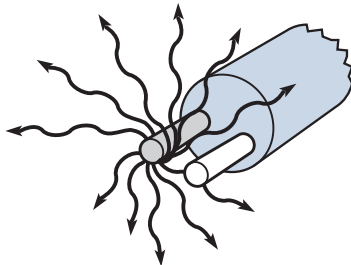

High Level

As media contacts the sensor tip, heat is absorbed by the fluid, decreasing the temperature difference.

FLOW SWITCH

Flow is detected by an increase in heat transfer that occurs as the flow rate increases. Exceptional low flow sensitivity is obtained with no moving parts. The same unit can be used for both liquid and gas flow detection.

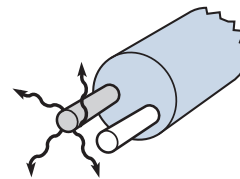

No Flow

In a low flow condition, the self-heated sensor tip creates a temperature differential between the two sensors.

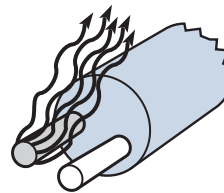

Flow

As flow increases, heat is dissipated and temperature difference decreases.

PROBE DESIGNS

Thermatel offers two sensor tip designs—the original twin tip and the unique spherical tip. Both designs have similar operating ranges.

The sensors in the twin tip are mounted at the end of each tip. In the spherical tip, the sensors are bonded directly to the wall of the tip, providing protection of the sensors.

The spherical tip is recommended for all types of applications—general purpose, high viscosity, full vacuum, and applications where buildup can occur.

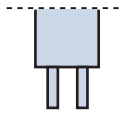

Twin tip

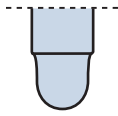

Spherical tip

Typical Air Flow

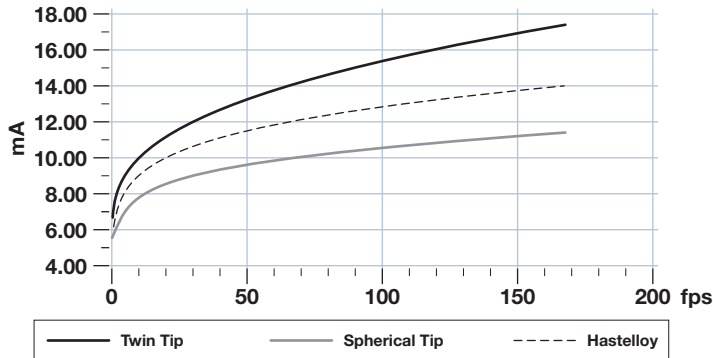

Typical Water Flow

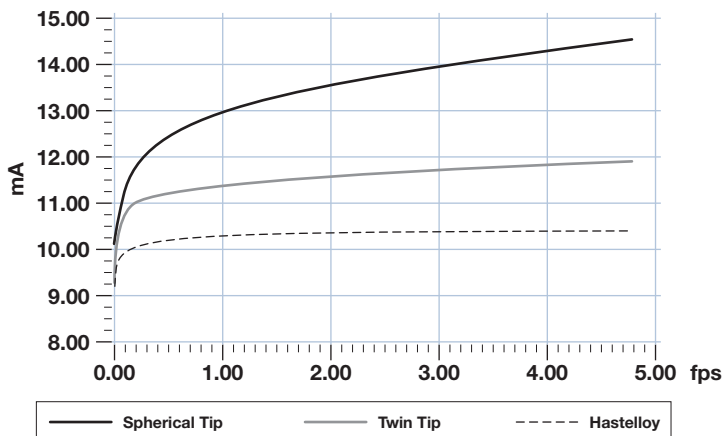

Spherical Tip

For general purpose use, liquid flow applications, and buildup. Suitable for gas flow applications. Maximum temperature of +400 °F (+204 °C).

Twin Tip

Twin tip probes are preferred for higher pressures up to 3000 psig, corrosion resistant materials including Monel and Hastelloy C, and gas flow applications. Maximum temperature of +400 °F (+204 °C).

High Temperature/High Pressure (HTHP)

Suitable for temperatures up to +850 °F (+454 °C) and pressures up to 6000 psi (410 bar). Available in both 316/316L stainless steel and Hastelloy C construction.

Mini Sensor

This twin tip sensor is suitable for installing into a Tee in smaller pipe sizes. Available with ½", ¾" and 1" NPT connections for use with appropriate tee connection. The twin tip design provides minimal blockage of the pipe.

Low Flow Body

Used for even lower flow rates with ¾" and ½" threaded connections.

Recommended set point ranges for various size tees

Size	Water	Air
¼" Flow body	0.0055 – 1.5 GPH (0.02 – 5.7 l/h)	2.5 to 200 SCFH ① (1180 sccm to 5.75 Nm³/h)
½" Flow body	0.01 to 3 GPH (0.04 to 11.5 l/h)	2.5 to 400 SCFH (1180 sccm to 11.5 Nm³/h)
½" Tee	0.2 to 180 GPH (0.75 to 680 l/h)	0.5 to 70 SCFM (0.85 to 120 Nm³/h)
¾" Tee	0.5 to 240 GPH (2 to 900 l/h)	1.5 to 100 SCFM (2.5 to 170 Nm³/h)
1" Tee	1 to 420 GPH (3.8 to 1600 l/h)	3 to 170 SCFM (5 to 290 Nm³/h)

① For 30 SCCM to 2.5 SCFH, use high sensitivity low flow body.

APPLICATIONS

PUMP PROTECTION

Installed on the suction or discharge of a pump, a Thermanel switch provides rapid indication of a low flow or no flow condition to prevent pump damage. No moving parts, excellent low flow sensitivity, and low hysteresis between alarm and reset points are all important features in this application. Enhanced temperature compensation minimizes set point drift due to varying process temperatures.

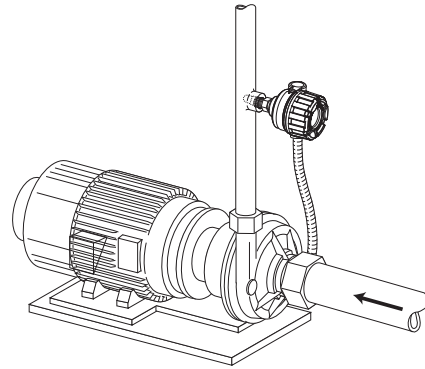

Pump Protection

COOLING WATER/COOLING AIR

Maintaining the flow of cooling air or water is essential to protect heat generating equipment. A reliable flow switch will ensure that sufficient cooling media is flowing in the pipe. A low flow alarm will provide indication of inadequate cooling prior to overheating of the device being protected.

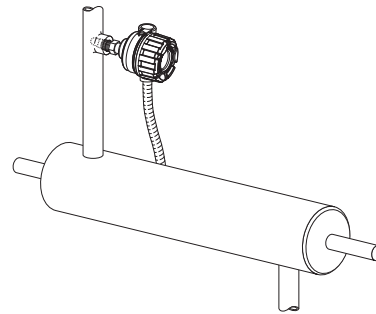

Cooling Water/Cooling Air

LEVEL

A Thermanel switch can be calibrated to detect the difference between two media based upon the difference in thermal conductivity. This can include wet/dry, oil/water interface, air/foam and foam/liquid. The sensitivity of the switch can easily be adjusted for a wide range of conditions. Probes can be mounted from the top or side of the tank.

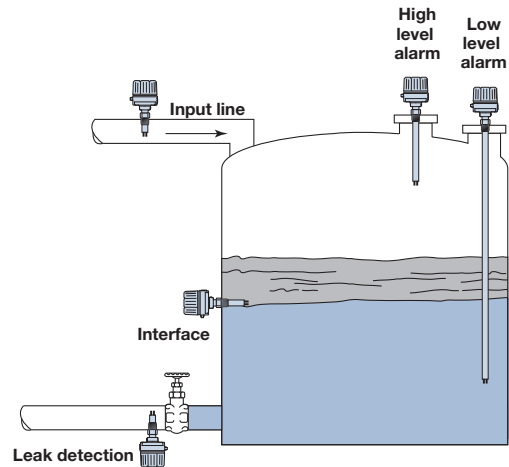

Level

CHEMICAL FEED PUMPS

Monitoring the addition of chemicals into a process is vital for good performance. The TD1/TD2 with the low flow body can handle extremely low flow rates of both liquids and gases. With the TD2, time delay can be added.

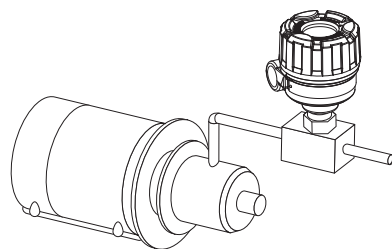

Chemical Feed Pump

APPLICATIONS

RELIEF VALVE MONITORING

When installed downstream of a relief valve, the switch can detect when flow occurs. The low flow sensitivity of the sensor permits the switches to be calibrated to detect minor valve leakage.

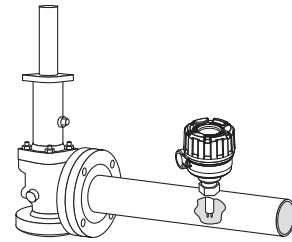

Relief Valve Monitoring

LUBRICATION SYSTEMS

The flow switch with the low flow body can be used to ensure that sufficient quantities of lubrication oil are flowing throughout the entire lubrication system. No moving parts and large openings prevent buildup or plugging which can occur with mechanical switches.

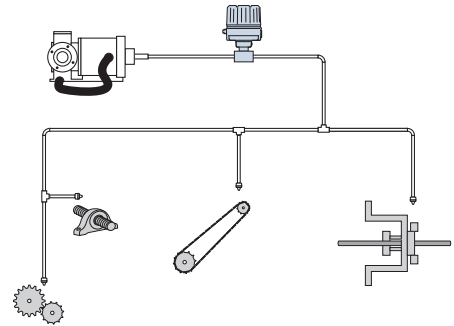

Lubrication Systems

OTHER APPLICATIONS

- Exhaust Flow Monitoring
- Seal Leakage
- Safety Showers/ Eyewash Stations
- Leak Detection
- Vacuum Pumps Seal Fluid
- Paint Flow
- Sampling Systems
- Analyzer Flow

SPECIFICATIONS

Supply Voltage	TD1 19.2 to 28.8 VDC --- TD2 19.2 to 28.8 VDC --- or 100 to 264 VAC \sim , 50–60 Hz
Power Consumption	TD1: 3.5 Watts at 24 VDC 4.5 Watts at 28.8 VDC TD2: 4 Watts at 24 VDC 4.5 Watts at 28.8 VDC 5 Watts at 100 to 264 VAC
Power to Probe	Less than 1 Watt
Output Relay (gold flashed)	TD1: DPDT, 8 amp at 120 VAC, 250 VAC 8 amp at 28.8 VDC, 0.5 amp at 125 VDC TD2: DPDT, 8 amp at 120 VAC, 250 VAC 8 amp at 28.8 VDC, 0.5 amp at 125 VDC or Hermetically Sealed DPDT 1 amp at 28 VDC, 0.2 amp at 125 VDC
Ambient Temperature	Electronics: -40 to +158 °F (-40 to +70 °C)
Storage Temperature	Electronics: -58 to +170 °F (-50 to +76 °C)
Operating Temperature	Sensor: -100 to +400 °F (-73 to +204 °C) ① High Temperature Sensor: -100 to +850 °F (-73 to +454 °C)
Response Time	1–10 seconds (typical – dependent upon sensor type, application, and set point adjustment)
Set Point Range	Water: 0.01 to 5.0 FPS (0.003 to 1.5 m/s) (spherical tip and twin tip sensors) 0.01 to 1.0 FPS (0.003 to 0.3 m/s) (HTHP, Hastelloy, Monel sensors) Air: 0.1 to 500 SFPS (0.03 to 150 Nm/s)
Time Delay (TD2 only)	0–100 seconds adjustable (time delay in addition to sensor response)

① Use a probe with heat extension or remote electronics for process temperatures greater than +250 °F (+120 °C)

SPECIFICATIONS (cont.)



Repeatability	<1% at constant temperature
Enclosure Material	Cast aluminum A356 containing less than 0.2% copper 316 stainless steel or 304 stainless steel
SIL	Safe Failure Fraction (SFF) TD1=69.3% TD2=73%
Probes:	
Probe Materials of Construction	Twin Tip: All wetted parts of 316/316L stainless steel, Hastelloy C, or Monel HTHP Sensor: 316/316L stainless steel, Hastelloy C Mini Sensor: 316/316L stainless steel Spherical Tip: 316/316L stainless steel Low Flow Body: 316/316L stainless steel
Process Connection	Refer to part number construction
Probe Insertion Length: Spherical Tip Probe, TXA, TXB Twin Tip Probe, TXC, TXD	Available in lengths from 2 to 130" in 1" increments (5 to 330 cm in 1 cm increments)
Mini Sensor, TXM	Available insertion lengths 1 to 130" (3 to 330 cm)
High Temperature Sensor, TXH	Available in lengths from 2 to 36" in 1" increments (5 to 91 cm in 1 cm increments); Consult factory for longer lengths.
Low Flow Body, TEL	¼" and ½" NPT and G (BSP) threads.
Cable Length	500 feet (150 meters) maximum

PRESSURE / TEMPERATURE RATING

(DEPENDENT ON PROCESS CONNECTION)

Probe Style	Insertion Length	Process/Temperature Rating			
		+100 °F (+38 °C)	+250 °F (+121 °C)	+400 °F (+204 °C)	+850 °F (+454 °C)
Twin Tip (TXC, TXD) (stainless steel)	2" (5 cm)	3000 psig (206 bar)	2460 psig (169 bar)	2140 psig (147 bar)	—
	3–130" (7–330 cm)	1850 psig (127 bar)	1517 psig (104 bar)	1320 psig (91 bar)	—
Twin Tip (TXC, TXD) (Hastelloy C)	2" (5 cm)	3000 psig (206 bar)	2627 psig (181 bar)	2340 psig (161 bar)	—
	3–130" (7–330 cm)	1500 psig (103 bar)	1313 psig (90 bar)	1170 psig (80 bar)	—
Twin Tip (TXC, TXD) (Monel)	2" (5 cm)	2500 psig (172 bar)	2125 psig (146 bar)	1980 psig (136 bar)	—
	3–130" (7–330 cm)	1200 psig (82 bar)	1020 psig (70 bar)	950 psig (65 bar)	—
Spherical Tip (TXA, TXB)	2–130" (5–330 cm)	600 psig (41 bar)	490 psig (34 bar)	415 psig (28 bar)	—
Spherical Tip (TXA, TXB) (NACE/ASME)	2–130" (5–330 cm)	400 psig (27 bar)	325 psig (22 bar)	275 psig (19 bar)	—
Mini Sensor (TXM)	1" (2.5 cm)	3000 psig (206 bar)	2460 psig (169 bar)	2140 psig (147 bar)	—
	2–130" (5–330 cm)	1850 psig (127 bar)	1517 psig (104 bar)	1320 psig (91 bar)	—
Low Flow Body (TEL)	—	7500 psig (517 bar)	7500 psig (517 bar)	7250 psig (500 bar)	—
High Sensitivity Low Flow Body (TEL)	—	5800 psig (400 bar)	4760 psig (328 bar)	4100 psig (282 bar)	—
High Temperature/ High Pressure (TXH)	2–36" (5–90 cm)	6000 psig (413 bar)	4920 psig (339 bar)	4280 psig (295 bar)	3380 psig (233 bar)

AGENCY APPROVALS

AGENCY	MODEL APPROVED	APPROVAL CATEGORY	APPROVAL CLASSES
FM/FMc 	TD1-2D00-0XX TD2-XX0X-Xab a = 3, C, G b = 0, 1, 2, 3	Explosion Proof	FM19US0169/FM19CA0128X Class I, Div 1; Groups B, C, D TD1=T5 TD2=T5 Class II & III, Div 1; Groups E, F, G Type 4X, $-40^{\circ}\text{C} \leq \text{Ta} \leq +70^{\circ}\text{C}$
	TD1-2D00-0X0 TD2-XX0X-Xab a = 3, C, G b = 0, 1, 2, 3	Flame Proof <input type="checkbox"/> indicates probe	CI I, Zn 0, 1, AEx/Ex db+ib/db, Grp IIC T5...T4 Ga/Gb <input type="checkbox"/> CI I, Zn 1, AEx/Ex db IIC T5 Gb <input type="checkbox"/> CI I, Zn 0,1 AEx/Ex db IIC T5 Ga/Gb <input type="checkbox"/> CI I, Zn 0, 1, AEx/Ex db+ib, Grp IIC T5...T4 Ga/Gb Type 4X and IP66, $-40^{\circ}\text{C} \leq \text{Ta} \leq +70^{\circ}\text{C}$
	TD1-2D00-0XX TD2-XX0X-XXX	Non-Incendive	Class I, Div 2; Groups A, B, C, D Class II & III, Div 2; Groups E, F, G T4 Type 4X, $-40^{\circ}\text{C} \leq \text{Ta} \leq +70^{\circ}\text{C}$
	PROBE MODEL TXX-XXXX-XXX	Explosion Proof <input type="checkbox"/> indicates probe	<input type="checkbox"/> Class I, Div 1; Groups B, C, D T4 <input type="checkbox"/> Class II & III, Div 1; Groups E, F, G Type 4X, $-40^{\circ}\text{C} \leq \text{Ta} \leq +70^{\circ}\text{C}$
For probe rating: Select the type of protection and mark one of the boxes. Once the type of protection is selected, it shall not be changed			
ATEX/IEC 	Zone 0 Service TXX-XDXX-XXC	Ex db Flame Proof <input type="checkbox"/> indicates probe	FM 19ATEX0203X/IECEx FMG 19.0047X Ⓢ II 1/2 G Ex db+ ib/db IIC T5...T4 Ga/Gb II 2(1) G Ex db [ib] IIC T4 Gb <input type="checkbox"/> II 1/2 G Ex db IIC T5...T4 Ga/Gb <input type="checkbox"/> II 1/2 G Ex db+ib IIC T5...T4 Ga/Gb $-40^{\circ}\text{C} \leq \text{Ta} \leq +70^{\circ}\text{C}$
	TXX-XHXX-XXC	Ex db Flame Proof	IEC Ex db IIC T5...T4 Gb IP66, $-40^{\circ}\text{C} \leq \text{Ta} \leq +70^{\circ}\text{C}$ (Zone 0 in conjunction with hermetically sealed relay: Probe must be twin tip design and made from Hastelloy C, Monel, or 1mm thick stainless steel.)
	Zone 1 Service TXX-XXXX-XGX	Ex db Flame Proof	Ⓢ II 2 G Ex db IIC T5...T4 Gb IEC Ex db IIC T5...T4 Gb IP66 $-40^{\circ}\text{C} \leq \text{Ta} \leq +70^{\circ}\text{C}$
	PROBE MODEL TXX-XXXX-XXX		II 2 G Ex db IIC T5...T4 Gb $-40^{\circ}\text{C} \leq \text{Ta} \leq +70^{\circ}\text{C}$
INMETRO 	Zone 0 Service TD1-2D00-0XX TD2-XD0X-XXC TXX-XHXX-XXC	Ex db Flame Proof w/IS probe circuit Ex db Flame Proof	BR-Ex d[ib] IIC T5/T4 IP66 - Electronics BR-Ex d+ib IIC T5/T4 IP66 - Probe BR-Ex d IIC T5/T4 IP66 (Zone 0 in conjunction with hermetically sealed relay: Probe must be twin tip design and made from Hastelloy C, Monel, or 1mm thick stainless steel.)
	Zone 1 Service TXX-XXXX-XGX	Ex d Flame Proof	BR-Ex d IIC T5/T4 IP66
	EAC TDX-XXXX-XXC TDX-XXXX-XGX		Russian Authorisation Standards Consult MAGNETROL for details.
CCOE TDX-XXXX-XXC TDX-XXXX-XGX		Hazardous Approvals - India Consult MAGNETROL for details.	
KGS TDX-XXXX-XXC TDX-XXXX-XGX		Hazardous Approvals - Korea Consult MAGNETROL for details.	

 These units have been tested to EN 61326 and are in compliance with the EMC Directive 2014/30/EU.

MODEL NUMBER

T D 1

 Models available for quick shipment, usually within one week after factory receipt of a complete purchase order, through the Expedite Ship Plan (ESP)

AGENCY APPROVAL

3	General Purpose, FM/CSA Explosion Proof approved
C	ATEX/IECEX Ex d + ib, Zone 0 – Flameproof

ENCLOSURE TYPE/CONDUIT CONNECTION

0	Aluminum A356 - 3/4" NPT (dual entry)
1	Aluminum A356 - M20 (dual entry)



MODEL NUMBER

T D 2

POWER

7	AC Power
8	DC Power

RELAY OUTPUT

D	DPDT Relay
H	DPDT hermetically sealed relay

GLASS WINDOW IN ENCLOSURE

0	None
1	Window provided (not available on enclosure types 2 & 3)

LOCATION

0	Integral
1	Remote (not available on enclosure code 4 & 5)

AGENCY

3	General Purpose & FM/CSA Class I, Division 1 & 2
C	ATEX/IECEX Ex d + ib - Zone 0
G	ATEX/IECEX Ex d – Zone 1

ENCLOSURE TYPE/CONDUIT CONNECTION

0	Aluminum A356 – 3/4" NPT (dual entry)
1	Aluminum A356 – M20 (dual entry)
2	Cast 316 stainless steel – 3/4" NPT (dual entry)
3	Cast 316 stainless steel – M20 (dual entry)

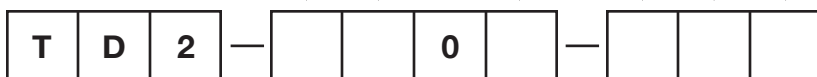

MODEL NUMBER

STANDARD PROBE

MODEL

TE	Probe length in inches
TM	Probe length in centimeters

TIP STYLE

A	Spherical tip ①	max. +250 °F (+121 °C)
B	Spherical tip – with 6-inch (15 cm) heat extension ①	max. +400 °F (+204 °C)
C	Twin tip	max. +250 °F (+121 °C)
D	Twin tip – with 6-inch (15 cm) heat extension	max. +400 °F (+204 °C)

① Available only with stainless steel construction

MATERIAL OF CONSTRUCTION

A	316/316L stainless steel
B	Hastelloy C
C	Monel 400
D	316/316L stainless steel twin tip with 1 mm probe thickness. Available only with TMC or TMD probes.
F	Hastelloy C, NACE
G	Monel 400, NACE
K	316/316L stainless steel, ASME B31.3 (CRN Available)
M	316/316L stainless steel, ASME B31.3 and NACE (CRN Available)
N	316/316L stainless steel, NACE

PROCESS CONNECTION SIZE/TYPE

00	Compression Fitting (customer-supplied)
11	¾" NPT Thread
21	1" NPT Thread
22	G1 (1" BSP) Thread

ASME RAISED FACE FLANGE CONNECTIONS

23	1"	150#	ASME RF Flange	35	1½"	600#	ASME RF Flange
24	1"	300#	ASME RF Flange	43	2"	150#	ASME RF Flange
25	1"	600#	ASME RF Flange	44	2"	300#	ASME RF Flange
33	1½"	150#	ASME RF Flange	45	2"	600#	ASME RF Flange
34	1½"	300#	ASME RF Flange				

EN FLANGED CONNECTIONS ②

BA	DN 25	PN 16	EN 1092-1 Type A	CC	DN 40	PN 63/100	EN 1092-1 Type B2
BB	DN 25	PN 25/40	EN 1092-1 Type A	DA	DN 50	PN 16	EN 1092-1 Type A
BC	DN 25	PN 63/100	EN 1092-1 Type B2	DB	DN 50	PN 25/40	EN 1092-1 Type A
CA	DN 40	PN 16	EN 1092-1 Type A	DD	DN 50	PN 63	EN 1092-1 Type B2
CB	DN 40	PN 25/40	EN 1092-1 Type A	DE	DN 50	PN 100	EN 1092-1 Type B2

② EN flanges only available in metric length (TMX) probes.

INSERTION LENGTH

002	2" to 130" in 1" increments ③ Example: 4 inches = code 004 Note: minimum 3" with flanges, G1 (BSP) threads
-----	--

005	Minimum length 50 mm with NPT Threads
008	Minimum length 80 mm with G1 (BSP) and flange connections
	Extended lengths in 10 mm increments to length 3300 mm ③ Examples: 50 mm = code 005 , 3300 mm = code 330

③ Longer lengths available — consult factory (only 2" model is ESP)



MODEL NUMBER

HIGH TEMPERATURE / HIGH PRESSURE PROBE

MODEL

TE	Probe length in inches
TM	Probe length in centimeters

TIP STYLE

H	High temperature/high pressure twin tip	max. +850 °F (+450 °C)/max. 6000 psi (413 bar)
---	---	--

MATERIAL OF CONSTRUCTION

A	316/316L stainless steel
B	Hastelloy C
D	316/316L stainless steel twin tip with 1 mm probe thickness – Available only with TMH probes.
F	Hastelloy C, NACE
K	316/316L stainless steel, ASME B31.3 (CRN Available)
M	316/316L stainless steel, ASME B31.3 and NACE (CRN Available)
N	316/316L stainless steel, NACE

PROCESS CONNECTION SIZE/TYPE

11	¾" NPT Thread
21	1" NPT Thread
22	G1 (1" BSP) Thread

ASME RAISED FACE FLANGE CONNECTIONS

23	1"	150#	ASME RF Flange	37	1½"	900/1500#	ASME RF Flange
24	1"	300#	ASME RF Flange	38	1½"	2500#	ASME RF Flange
25	1"	600#	ASME RF Flange	43	2"	150#	ASME RF Flange
27	1"	900/1500#	ASME RF Flange	44	2"	300#	ASME RF Flange
33	1½"	150#	ASME RF Flange	45	2"	600#	ASME RF Flange
34	1½"	300#	ASME RF Flange	47	2"	900/1500#	ASME RF Flange
35	1½"	600#	ASME RF Flange	48	2"	2500#	ASME RF Flange

EN FLANGED CONNECTIONS ①

BA	DN 25	PN 16	EN 1092-1 Type A	DA	DN 50	PN 16	EN 1092-1 Type A
BB	DN 25	PN 25/40	EN 1092-1 Type A	DB	DN 50	PN 25/40	EN 1092-1 Type A
BC	DN 25	PN 63/100	EN 1092-1 Type B2	DD	DN 50	PN 63	EN 1092-1 Type B2
BG	DN 25	PN 250	EN 1092-1 Type B2	DE	DN 50	PN 100	EN 1092-1 Type B2
CA	DN 40	PN 16	EN 1092-1 Type A	DG	DN 50	PN 250	EN 1092-1 Type B2
CB	DN 40	PN 25/40	EN 1092-1 Type A	DJ	DN 50	PN 400	EN 1092-1 Type B2
CC	DN 40	PN 63/100	EN 1092-1 Type B2				
CG	DN 40	PN 250	EN 1092-1 Type B2				
CJ	DN 40	PN 400	EN 1092-1 Type B2				

① EN flanges only available on metric length (TMX) probes.

INSERTION LENGTH

2" to 36" in 1" increments ②
 Example: 6-inch probe = **006**
 Note: minimum 3" with Flanges and G1 (BSP) threads

005	Minimum length 50 mm with NPT Threads
007	Minimum length 70 mm with G1 (BSP) or flange connections
Extended lengths in 10 mm increments to 910 mm ②	
Examples: 50 mm = code 005 , 910 mm = code 091	

② Longer lengths available — consult factory

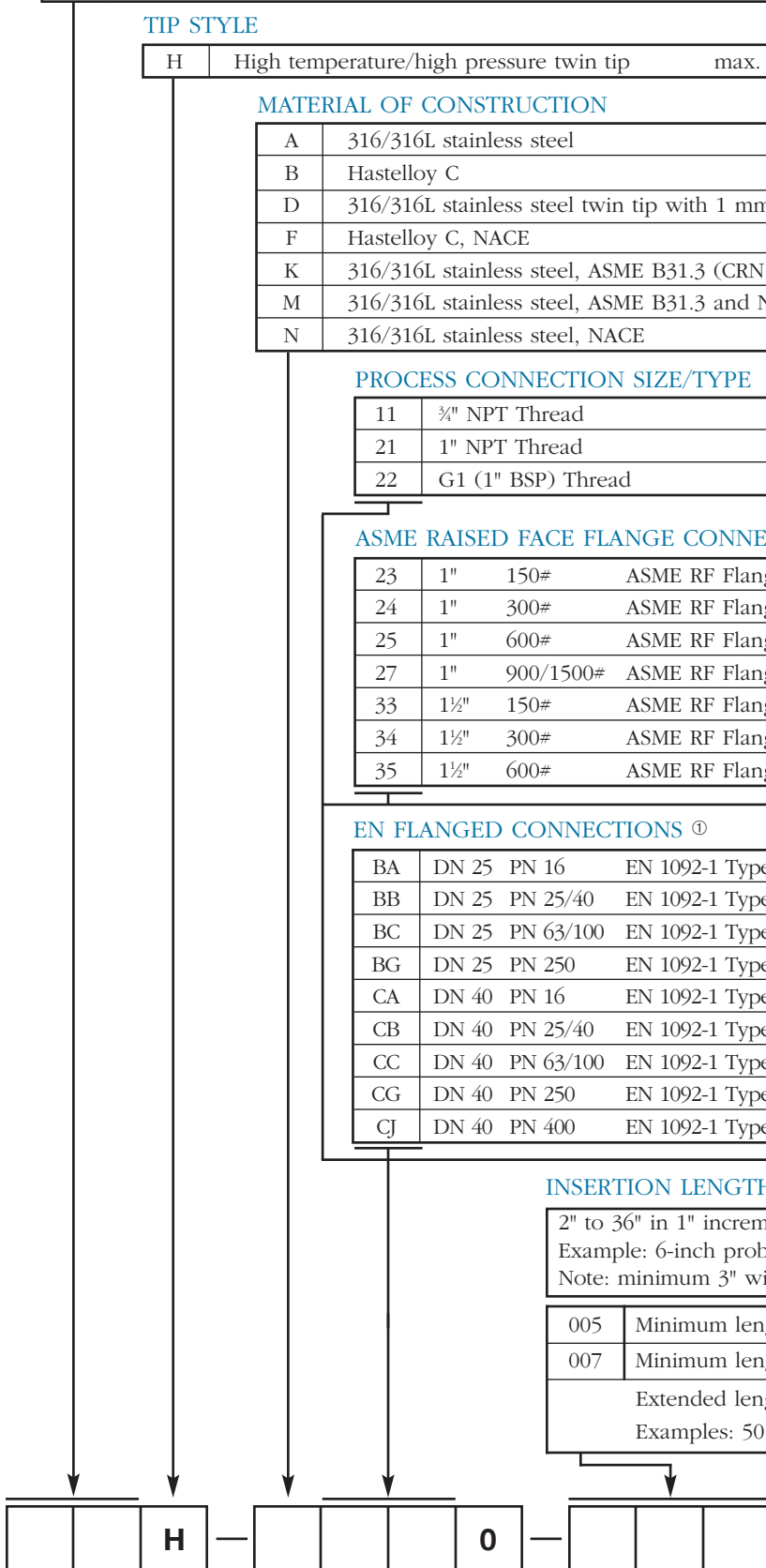

MODEL NUMBER

LOW FLOW BODY

MODEL

TEL	Low Flow Body
-----	---------------

MATERIAL OF CONSTRUCTION

A	316/316L stainless steel
---	--------------------------

PROCESS CONNECTION SIZE/TYPE

T1	¼" NPT Thread (CRN Available)
V1	½" NPT Thread (CRN Available)
T0	G ¼ (¼" BSP) Thread
V0	G ½ (½" BSP) Thread

SENSITIVITY

0	Standard
1	High Sensitivity ①

MOUNTING BRACKET

000	None
100	With mounting bracket

① Available only for gas applications and when digit 5 = T



MINI SENSOR

MODEL

TE	Probe length in inches
TM	Probe length in centimeters

BODY STYLE

M	Mini twin tip	max. +400 °F (+204 °C)/max. 3000 psi (207 bar) for standard sensor length max. +400 °F (+204 °C)/max. 1850 psi (127 bar) for sensors ≥ 2 inches (50 mm)
---	---------------	--

MATERIAL OF CONSTRUCTION

A	316/316L stainless steel (CRN Available)
N	316/316L stainless steel, NACE (CRN Available)

PROCESS CONNECTION SIZE/TYPE

01	½" NPT Thread
11	¾" NPT Thread
21	1" NPT Thread

INSERTION LENGTH

001	1" to 130" in 1" increments Example: 6 inch probe = code 006
-----	--

	50 mm to 3300 mm in 10 mm increments Examples: 50 mm = code 005, 3300 mm = code 330 Note: Use code 003 for minimum length of 25 mm
--	--

Use 1-inch long probe when used with tee.

Example: Model Number of probe to fit in a ¾" tee is TEM-A110-001 or TMM-A110-003.

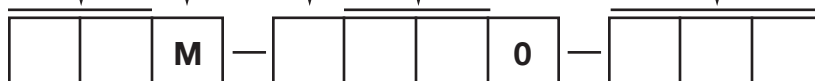

MODEL NUMBER

CONNECTING CABLE (GENERAL PURPOSE, FM/CSA)

CONNECTING CABLE IN FEET

10 feet minimum, 500 feet maximum length
 Example: 12 feet = Code **012**

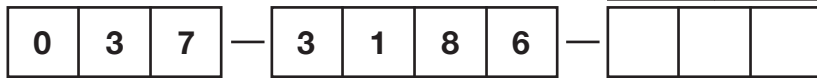

CONNECTING CABLE IN METERS

3 meters minimum, 152 meters maximum length
 Example: 3 meters = Code **003**

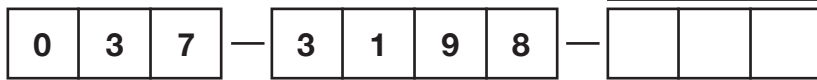

DIMENSIONAL SPECIFICATIONS

INCHES (MM)

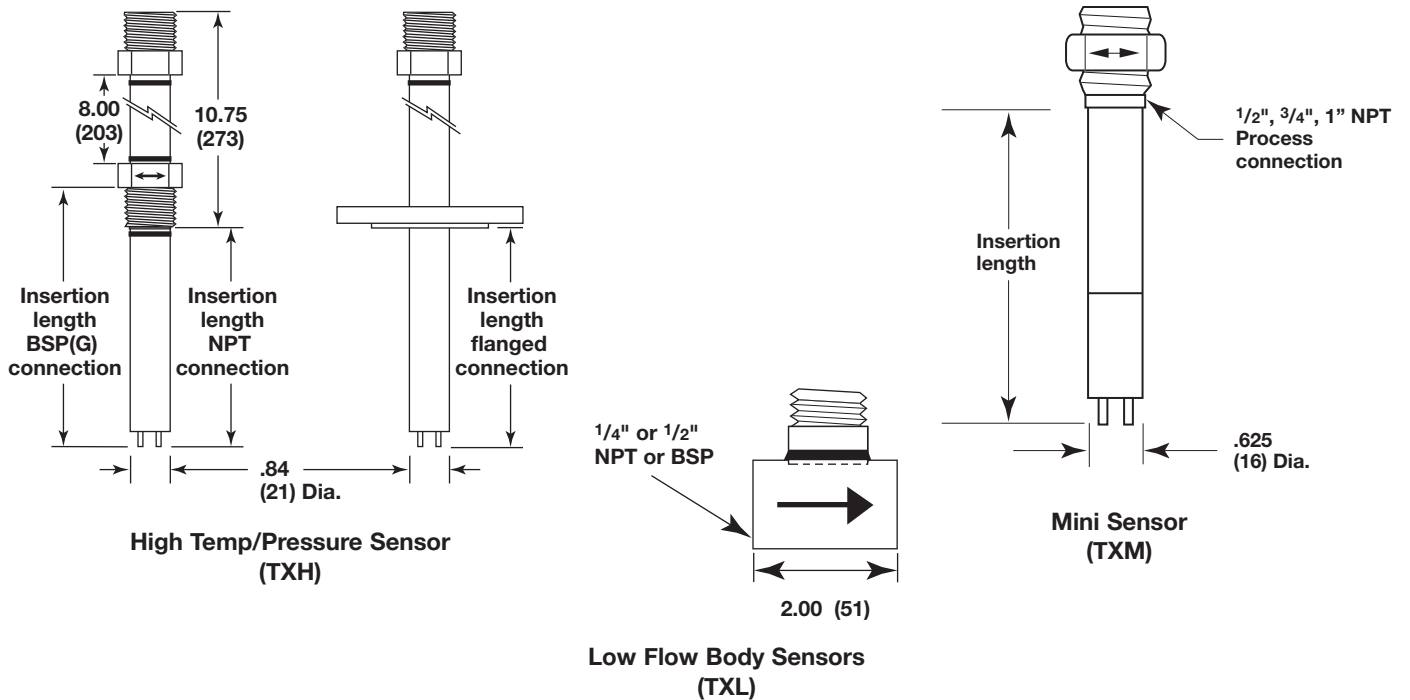

DIMENSIONAL SPECIFICATIONS (cont.)

INCHES (MM)

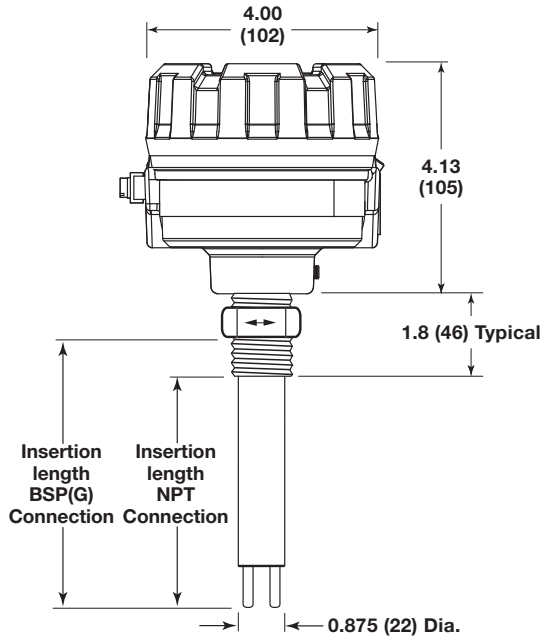

Model TD1
with Twin Tip Sensor

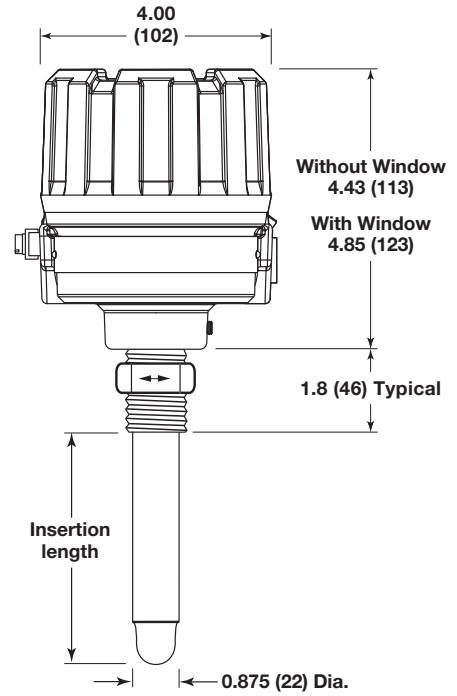

Model TD2
Integral Electronics
with Spherical Tip Sensor

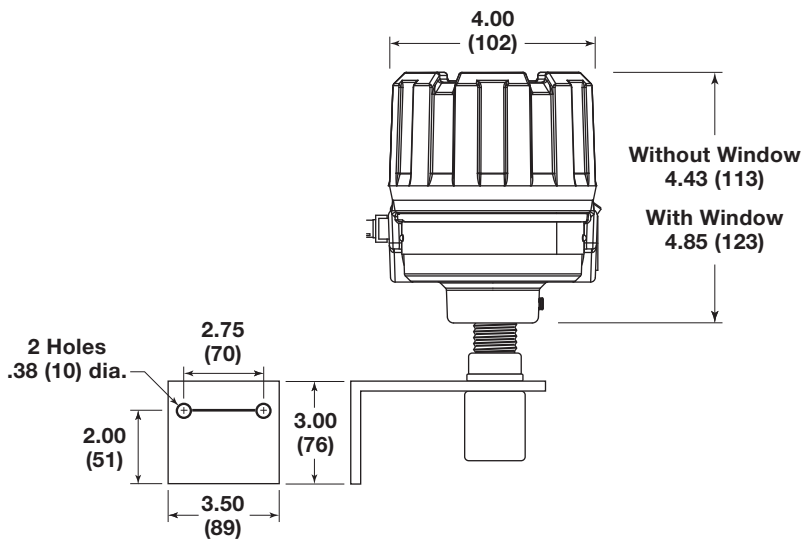

Model TD2 with Remote Electronics

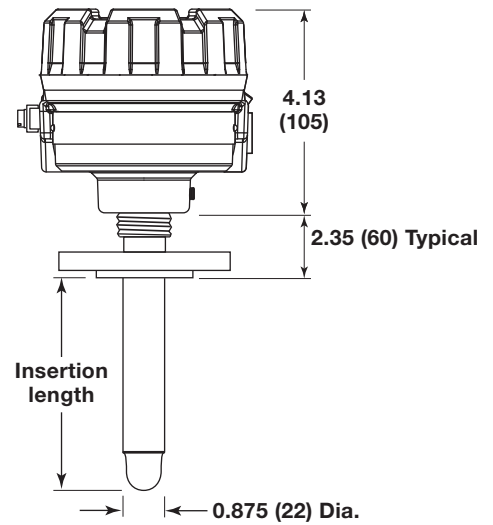

Remote Spherical Tip Probe
with Flange Connection

QUALITY



The quality assurance system in place at Magnetrol guarantees the highest level of quality throughout the company. Magnetrol is committed to providing full customer satisfaction both in quality products and quality service.

The Magnetrol quality assurance system is registered to ISO 9001 affirming its commitment to known international quality standards providing the strongest assurance of product/service quality available.

ESP

Expedite **S**hip **P**lan

Several Thermatel flow and level switches are available for quick shipment, usually within one week after factory receipt of a complete purchase order, through the Expedite Ship Plan (ESP).

Models covered by ESP service are color coded in the selection data charts.

To take advantage of ESP, simply match the color coded model number codes (standard dimensions apply).

ESP service may not apply to orders of ten units or more. Contact your local representative for lead times on larger volume orders, as well as other products and options.

WARRANTY



All Magnetrol electronic level and flow controls are warranted free of defects in materials or workmanship for eighteen months from the date of original factory shipment.

If returned within the warranty period; and, upon factory inspection of the control, the cause of the claim is determined to be covered under the warranty; then, Magnetrol will repair or replace the control

at no cost to the purchaser (or owner) other than transportation.

Magnetrol shall not be liable for misapplication, labor claims, direct or consequential damage or expense arising from the installation or use of equipment. There are no other warranties expressed or implied, except special written warranties covering some Magnetrol products.

For additional information, see:
Thermatel Model DD1/TD2 Instruction Manual 54-610
Hot Tap Retractable Probe Assembly Instruction Manual 41-103



magnetrol.com

Copyright © 2022 AMETEK Magnetrol USA, LLC

Performance specifications are effective with date of issue and are subject to change without notice.

BULLETIN: 54-110.8
EFFECTIVE: August 2020
SUPERSEDES: May 2019