

Dual Modular Safety Shutoff Valves with Two-stage operation

DMV-ZRD/602 Series
DMV-ZRDLE/602 Series

DUNGS[®]
Combustion Controls



Two normally closed automatic shutoff valves in one housing; each with the following approvals.

UL Recognized

- UL 429
- File # MH16727

CSA Certified

- ANSI Z21.21
- CSA 6.5
- Marked C/I
- File # 1074737

FM Approved

- Class 7411
- Report # J.I. 3007653

Commonwealth of Massachusetts Approved Product

- Approval code G1-1107-35
- Gas safety shutoff valve

Codes and Standards

This product is intended for installations covered by but not limited to ANSI Z83.4, ANSI Z83.18, ANSI Z21.13, NFPA 86, NFPA 160, CSD-1, CSA B149.1 and CSA B149.3.

DUNGS is an ISO 9001 manufacturing facility.

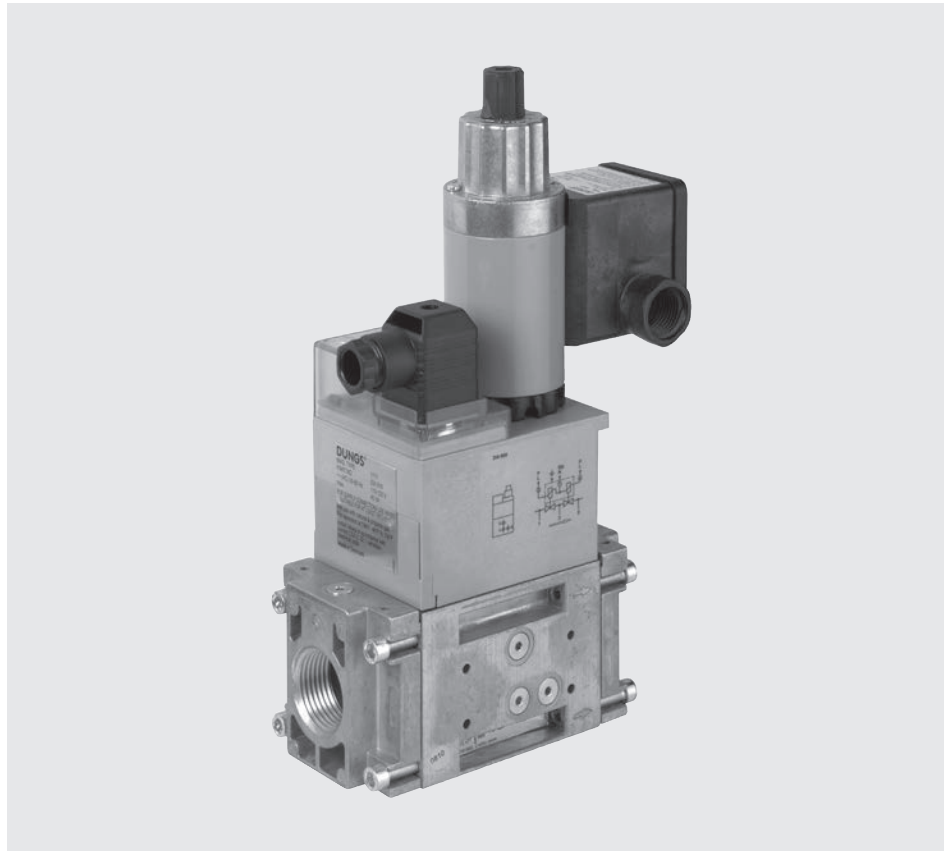

Description

The Two-Stage Dual Modular Valve (DMV-ZR) combines two safety shutoff valves in one compact housing, which can be wired independently or in parallel. Valve 2 incorporates two stages, which can be set at two different firing rates. Both firing rates are field adjustable and can modulate from high to low during burner operation.

Valve 1(V1) of the DMV-ZRD and DMV-ZRDLE series is fast opening and fast closing. Valve 2 (V2) is a two stage valve. V2 of the DMV-ZRD is fast opening, while V2 of the DMV-ZRDLE is slow-opening for smoother light-off. Max. flow adjustment on V2 provides variable main flow on both models.

Internal profiles and compact design optimize flow and provide a low pressure

drop. Three body styles reduce inventory. Directly mounting the following accessories creates a compact valve train without additional piping: pressure regulator, high and low gas pressure switches, valve proving system, and vent line adapter.

Application

The DMV-ZR is recommended for industrial and commercial heating applications, where two automatic shutoff valves and modulating between two firing rates during burner operation are required. The DMV-ZR Dual Modular Valve two stage is suitable for dry natural gas, propane, butane, air and inert gases.

A “dry” gas has a dew point lower than +15 °F and its relative humidity is less than 60 %.

DMV-ZR.../602 Two normally closed safety shutoff valves in one housing. V1 and V2 are fast opening, fast closing. Two stage and adjustable max flow with V2.

DMV-ZRDLE.../602 Two normally closed safety shutoff valves in one housing. V1 fast opening, fast closing. V2 is a two stage, slow opening, fast closing valve. Adjustable max. flow and adjustable initial lift with V2.

Specifications

Body sizes	DMV-ZRD(LE) 701	DMV-ZRD(LE) 702	DMV-ZRD(LE) 703
Pipe size / Thread	1/2" - 1" NPT	1" - 2" NPT	1" - 2" NPT
Max. operating pressure	7 PSI (500 mbar) UL, FM 5 PSI (360 mbar) CSA		
Max. body pressure	15 PSI (1000 mbar)		
Max. close off pressure	10 PSI (750 mbar)		
Electrical ratings (+10 % / -15 %)	110 - 120 VAC @ 50 - 60 Hz		
Power ratings	DMV 701: 70 VA	DMV 702: 85 VA	DMV 703: 115 VA
	Ratings shown are total power consumption for both valves inclusive. Inrush and full load current have the same VA rating.		
Enclosure rating	NEMA Type 12		
Electrical connection	DIN-connector with 1/2" NPT conduit adapter for valve 1 and valve 2, stage one. Screw terminals with 1/2" NPT conduit connection for valve 2, stage two. Use moisture-resistant No. 14 wire suitable for at least 194 °F (90°C)		
Operating time	100 % duty cycle		
Closing time	< 1 s		
Opening time (to max. flow)	DMV-ZRD.../602	V1 & V2 < 1 s	
	DMV-ZRDLE.../602	V1 < 1 s; V2 Adjustable to approx. 10 to 20 s at 70 °F	
Initial lift adjustment	Adjustable on V2 stage one, ZRDLE only; approx. 0 to 70 % of total flow		
Max. flow adjustment	Adjustable on V2, stage one: approx. 5 to 30 % of stroke Adjustable on V2, stage one: approx. 20 to 100 % of stroke		
Materials in contact with gas	Housing: Aluminium, Steel Sealings on valve seats: NBR-based rubber		
Ambient temperature rating	-20 °F to +150 °F (-30 °C to +65 °C)		
Installation position	Safety shutoff valve from vertically upright to horizontal		
Gas filter(optional)	Replaceable integral gas filter (50 micron) in inlet of DMV or Pre-Mount Filter Block for DMV 702 and 703. (Cannot be used with FRI directly mounted to the DMV)		
Gas strainer (standard)	Installed in the housing upstream V1 (23 mesh)		
Position indication (order separately)	CPI 400 with indication lamps and SPDT interlock switch or Visual Indicator (VI) for mechanical indication.		
Test ports / Pressure switch mounting ports	G 1/8 ISO 228 ports available on both sides. Each side has one port upstream V1, one between V1 and V2, one downstream V2 and one on each flange.		
Valve proving system (optional)	VPS 504; mounts directly to either side of DMV-ZRD(LE)		

Electrical connection

Use moisture-resistant No. 14 wire suitable for at least 194 °F (90 °C)

DIN Connector screw terminal connections

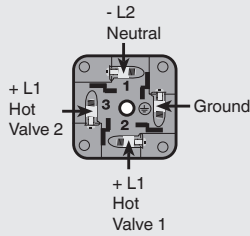

Valves V1 & V2 stage 1

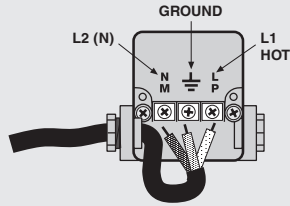

Valve V2 stage 2

Valves V1, V2 stage 1

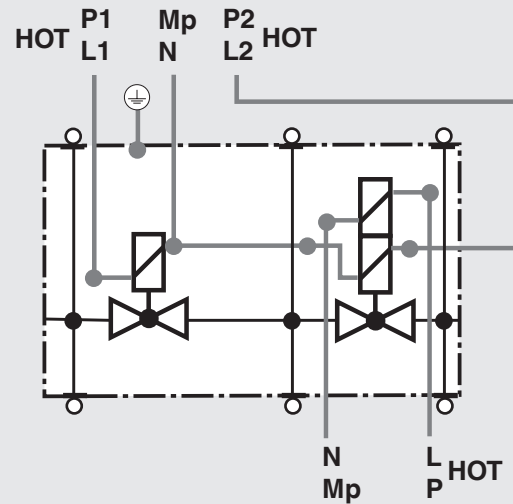

Valve V2 stage 2

Opening behavior DMV-ZRD(LE)/602

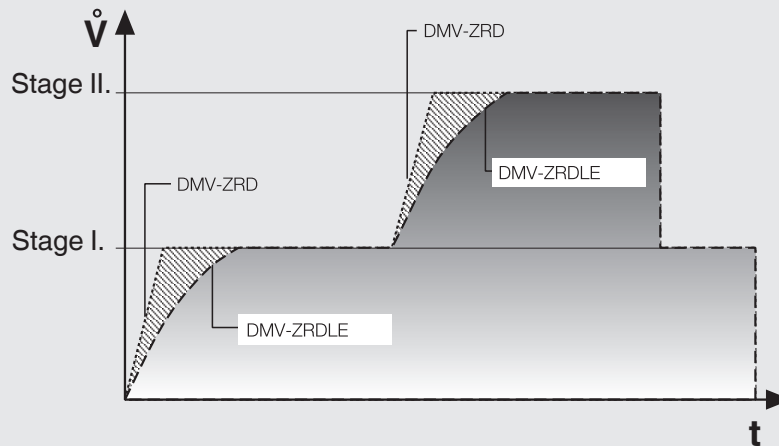

FRI Gas pressure regulator

Mounting the FRI series gas pressure regulator directly to the DMV dual safety shutoff valve is possible with a mounting kit.

The FRI pressure regulator can be installed upstream or downstream of the DMV dual safety shutoff valve depending on application requirements.

FRI mounting kit for DMV ZR

FRI 705 - 707/6 to DMV 701/602
Order No. 219967

FRI 710-712/6 to DMV 702/602 & 703/602

Order No. 219968

Additional Accesories

VPS 504

Valve proving system (approved by some authorities having jurisdiction in lieu of vent valve and "proof of closure" e.g. FM, IRI).

Integral gas filter (optional)

50 micron gas filter

Pre-Mount Filter (optional)

50 micron gas filter

GAO/GMH/GML A2 pressure switch

Valve Position Indication

CPI 400 with light indication lamps and SPDT interlock switch.

Visual Indicator (VI) for

mechanical valve position indication.

Vent Line Adapter

Factory installed vent line adapter which allows the installation of a normally open vent valve and vent line connection between both safety valves.

Other Adapters

- 1/4" NPT adapter (225047)
- 1/2" NPT Pilot gas adapter; Check flow requirements. (225043)
- G 1/8" Test nipple (219008)
- Port 3 Pressure switch mounting adapter (273777)



When an accessory is added to the DMV, it may not be possible to mount other devices.

Dimensions inch (mm)

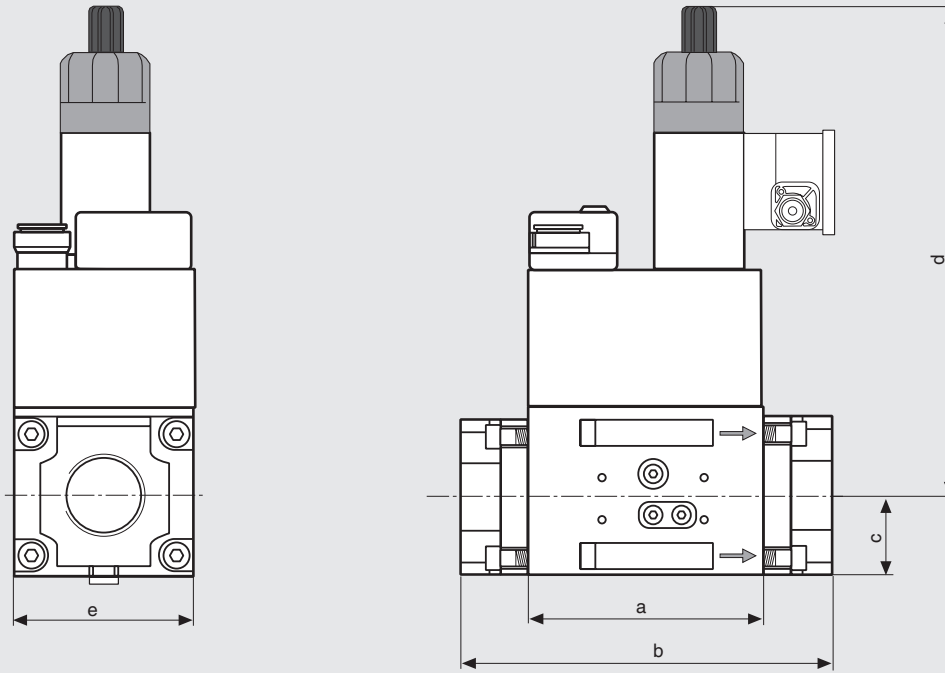

Type	110 - 120 VAC @ 50 - 60 Hz Order No.	Power* [VA]	Dimensions [inch] Dimensions [mm]					Weight [lbs] [kg]
			a	b**	c	d	e	
DMV-ZRD 701/602	231844	70	3.7 93	5.6 141	1.4 35	7.5 190	2.9 73	6.6 3,0
DMV-ZRD 702/602	232025	120	4.9 124	6.9 / 7.9 174 / 201	1.8 45	10.0 255	3.9 101	14.3 6,5
DMV-ZRD 703/602	232079	135	4.9 124	6.9 / 7.9 174 / 201	1.8 45	11.0 280	3.9 101	18.0 8,2
DMV-ZRDLE 701/602	232173	70	3.7 93	5.6 141	1.4 35	8.5 215	2.9 73	6.8 3,1
DMV-ZRDLE 702/602	232214	120	4.9 124	6.9 / 7.9 174 / 201	1.8 45	10.6 270	3.9 101	14.5 6,6
DMV-ZRDLE 703/602	232232	135	4.9 124	6.9 / 7.9 174 / 201	1.8 45	13.0 330	3.9 101	18.3 8,3

* Inrush current and full load current have the same VA rating.

** DMV 702 / 703 with 1" or 1 - 1/4" flange; "b" = 6.9" / DMV 702 / 703 with 1 - 1/2" or 2" flange; "b" = 7.9"

Valve Description	Flange	NPT	Rp
DMV-ZRD(LE) 701	1/2"	222371	222341
DMV-ZRD(LE) 701	3/4"	222368	222342
DMV-ZRD(LE) 701	1"	221999	222001
DMV-ZRD(LE) 702 & 703	1"	222369	222343
DMV-ZRD(LE) 702 & 703	1 1/4"	222370	222344
DMV-ZRD(LE) 702 & 703	1 1/2"	222003	221884
DMV-ZRD(LE) 702 & 703	2"	221997	221926

DIN-Connector	210319
CPI 400	266968
Visual indicator	266949

Integral Filter & Strainer	P/N
DMV-ZR 701	230440
DMV-ZR 702	230441
DMV-ZR 703	230441

 DMV-ZRD(LE)/602 flanges and other accessories are interchangeable

 Please order flanges, position indicators and gas filters separately

DMV-ZRDLE
sectional drawing

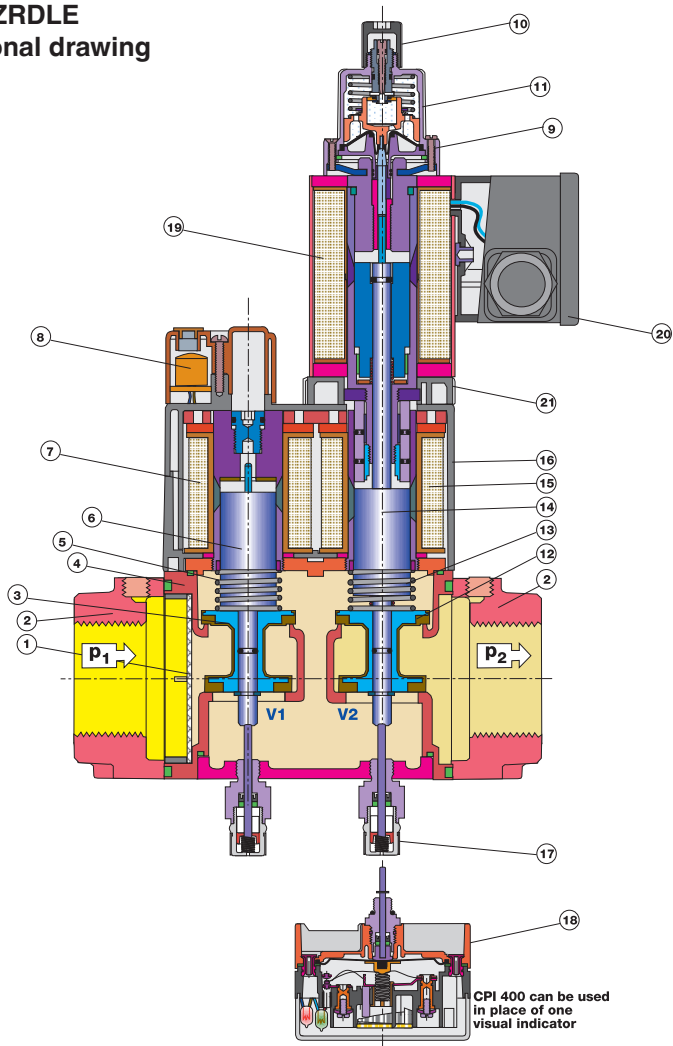

- 1 Strainer
- 2 Flange
- 3 Valve V1
- 4 Housing
- 5 Closing spring V1
- 6 Plunger V1
- 7 Solenoid V1
- 8 Electrical connection (V1 & stage 1 of V2)
- 9 Max flow adjustment (stage 2)
- 10 Initial lift adjustment (DMV-ZRDLE)
- 11 Hydraulic brake (DMV-ZRDLE)
- 12 Valve V2
- 13 Closing spring V2
- 14 Plunger V2
- 15 Solenoid V2 (stage 1)
- 16 Solenoid housing
- 17 Visual indicator (VI)
- 18 CPI 400 interlock switch
- 19 Solenoid V2 (stage 2)
- 20 Electrical connection (stage 2 of V2)
- 21 Main flow adjustment (stage 1)

Pressure drop for other gases

To determine the pressure drop when using a gas other than natural gas, use the flow formula below and f value located in the table below to determine

the “corrected” flow rate in CFH through the valve for the other gas used. For example, when using propane, divide the volume (CFH) of propane required for the application by the calculated value

f (f = 0.66 for propane). Use this “corrected” flow rate and the flow curve on the next page to determine pressure drop for propane.

Determining equivalent flow through valves using another gas

$$\dot{V}_{\text{gas used}} = \dot{V}_{\text{Natural gas}} \times f$$

$$f = \sqrt{\frac{\text{Density of Natural gas}}{\text{Density of gas used}}}$$

Type of gas	Density [kg/m ³]	s.g.	f
Natural gas	0.81	0.65	1.00
Butane	2.39	1.95	0.58
Propane	1.86	1.50	0.66
Air	1.24	1.00	0.80

Flow (CFH) of natural gas, s.g. 0.65 at 60 °F with 1 in. W.C. pressure drop

	1/2"	3/4"	1"	1 - 1/4"	1 - 1/2"	2"
DMV-ZR 701	345	429	457	-	-	-
DMV-ZR 702	-	-	1065	1277	1368	1430
DMV-ZR 703	-	-	1230	1532	1698	1795

Dual Modular Safety
Shutoff Valves with
Two-stage operation

DMV-ZRD/602 Series
DMV-ZRDLE/602 Series



Flow curve

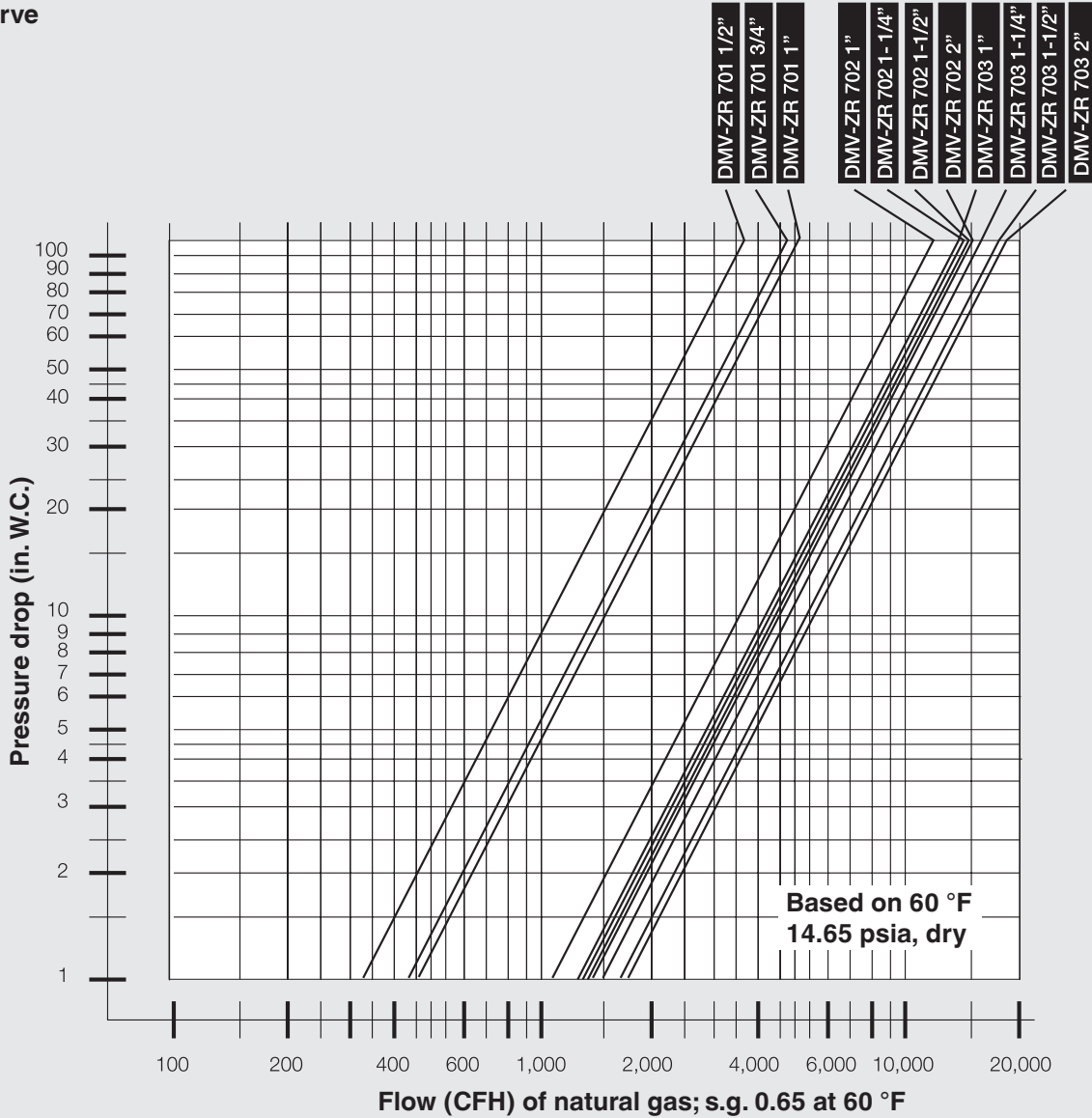

! Size valve for at least 2 in. W.C. of pressure drop or more if the inlet pressure in the application is 1/2 in. W.C. or less. Otherwise, the difference in flow rate between stage 1 and stage 2 will be noticeable.

We reserve the right to make any changes in the interest of technical progress.



Karl Dungs, Inc.
3890 Pheasant Ridge Drive NE
Suite 150
Blaine, MN 55449, U.S.A.
Phone 763 582-1700
Fax 763 582-1799
e-mail info@karldungsusa.com
Internet <http://www.dungs.com/usa/>

Karl Dungs GmbH & Co. KG
P.O. Box 12 29
D-73602 Schorndorf, Germany
Phone +49 (0)7181-804-0
Fax +49 (0)7181-804-166
e-mail info@dungs.com
Internet <http://www.dungs.com>