

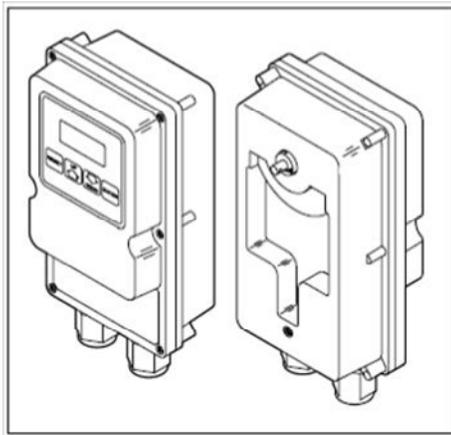

AC-4000
January 20, 2020



Fireeye[®] Actuators AC6Axx and AC6Bxx Servo Motor Installation

DESCRIPTION

This bulletin describes the installation and operating instructions for the AC6A and AC6B servo actuators.

SAFETY INFORMATION



WARNING: Make sure that you understand the structure and contents of this manual. Obey all the safety instructions. Do not deviate from any instructions or application limits in this manual without written consent from Fireeye. If you do not understand any part of the information in this manual, do not continue. Contact your Fireeye sales office or Fireeye.



WARNING: - All installation, service and troubleshooting of Fireeye products must be performed by a qualified technician!

The Fireeye rotary actuator is a keypad programmable, direct coupled, modulating motor for use in burner and valve control systems. It is typically used with an electronic control to regulate a process temperature. The drive shaft of the actuator connects to a butterfly valve stem, which rotates 90 degrees from minimum to maximum position.

Actuator features include: solid state electronics; LED display with membrane keys; 4-20mA, 0-10Vdc and switch inputs for positioning; and two auxiliary contacts for position feedback. Its construction complies with NEMA 4 standards.

The display keypad provides indication of position and direction of travel, and allows local manual positioning control. It also provides access to set the following parameters: minimum and maximum travel positions; actuation position for the auxiliary contacts; and direction of rotation.

The display keypad can be ordered in four positions: upright (standard) for vertical mounting with the wiring connections at the bottom; 90 degrees (RH) for horizontal mounting with the wiring connections to the right; 270 degrees (LH) for horizontal mounting with the wiring connections to the left; or inverted for mounting with the wiring connections at the top.

***Note:** The manufacturer of this equipment has a policy of continual product improvement and reserves the right to change the specification of the equipment and the contents of this manual without notice.*

These mounting and operating instructions are intended to give the knowledge which is necessary to carry out the mounting and adjustment of AC6Axx and AC6Bxx actuators safely and correctly.

***Note:** These instructions apply to heating applications where a maximum output from the temperature controller drives a butterfly valve up to its maximum flow position.*



SPECIFICATION DATA

Power Supply	<ul style="list-style-type: none"> • 120VAC (+10%, -15%), 50/60 Hz or 230VAC (+10%, -15%), 50/60 Hz • Internal power consumption: 5VA
Operating Temperature	<ul style="list-style-type: none"> • -20 to +60°C (0 to 140°F)
Temp. Range (Ambient)	<ul style="list-style-type: none"> • -25 to +65°C (-10 to +150°F)
Humidity	<ul style="list-style-type: none"> • 5 to 95% RH noncondensing
Inputs, Analog	<ul style="list-style-type: none"> • 4-20mA @ 250 impedance; 0-10Vdc @ 200K impedance
Inputs, Digital	<ul style="list-style-type: none"> • Isolated contacts: force to high position; force to low position; disable setting codes
Shaft Rotation	<ul style="list-style-type: none"> • 0 to 90°
Minimum Step	<ul style="list-style-type: none"> • 1°
Shaft Rotation Direction	<ul style="list-style-type: none"> • Selectable: clockwise or counterclockwise
Keypad Settings	<ul style="list-style-type: none"> • 0 to 90°
Keypad Orientation	<ul style="list-style-type: none"> • Four positions
Display Accuracy	<ul style="list-style-type: none"> • ± 1.5°
Position Indicator	<ul style="list-style-type: none"> • Seven segment LED, 0 to 90°
Speed	<ul style="list-style-type: none"> • 18 seconds for 90° @ 60Hz • Model 1ZD1, 18 seconds for 75° @ 60Hz
Torque	<ul style="list-style-type: none"> • 2.3 N-m (20 lb-in) • 3.9 N-m (35 lb-in) @ stall
Stalled Time Detect	<ul style="list-style-type: none"> • 30 seconds
Auxiliary Contact Ratings	<ul style="list-style-type: none"> • 50 VA • 25 VA
Resistive Load:	
Inductive Load:	
Wiring Connectors	<ul style="list-style-type: none"> • Flexible cord connector: 5.8 to 10mm (0.231 to 0.394) OD cable • 3/8" liquid tight conduit • 1/2" Female NPT adapter
Terminal Connections	<ul style="list-style-type: none"> • 0.5 to 2.5mm² (22 to 14 AWG)
Shipping Weight	<ul style="list-style-type: none"> • 1.1 kgs. (2.5 lbs.)

ORDERING INFORMATION

Model Number Configuration

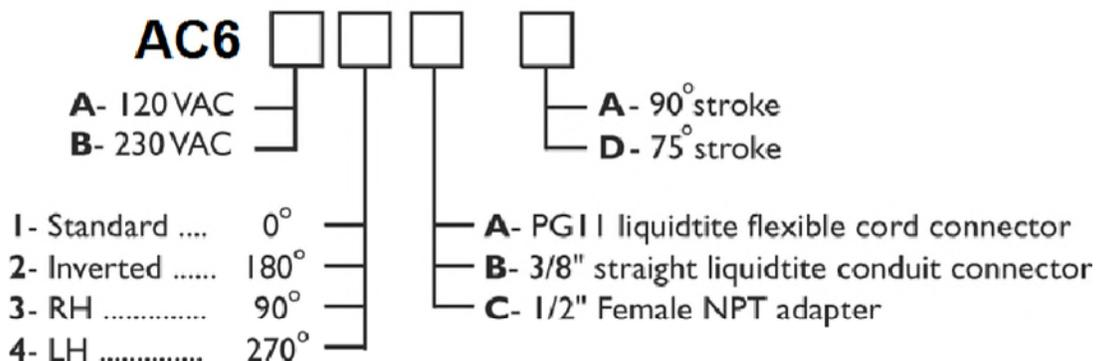



Actuator Dimensions

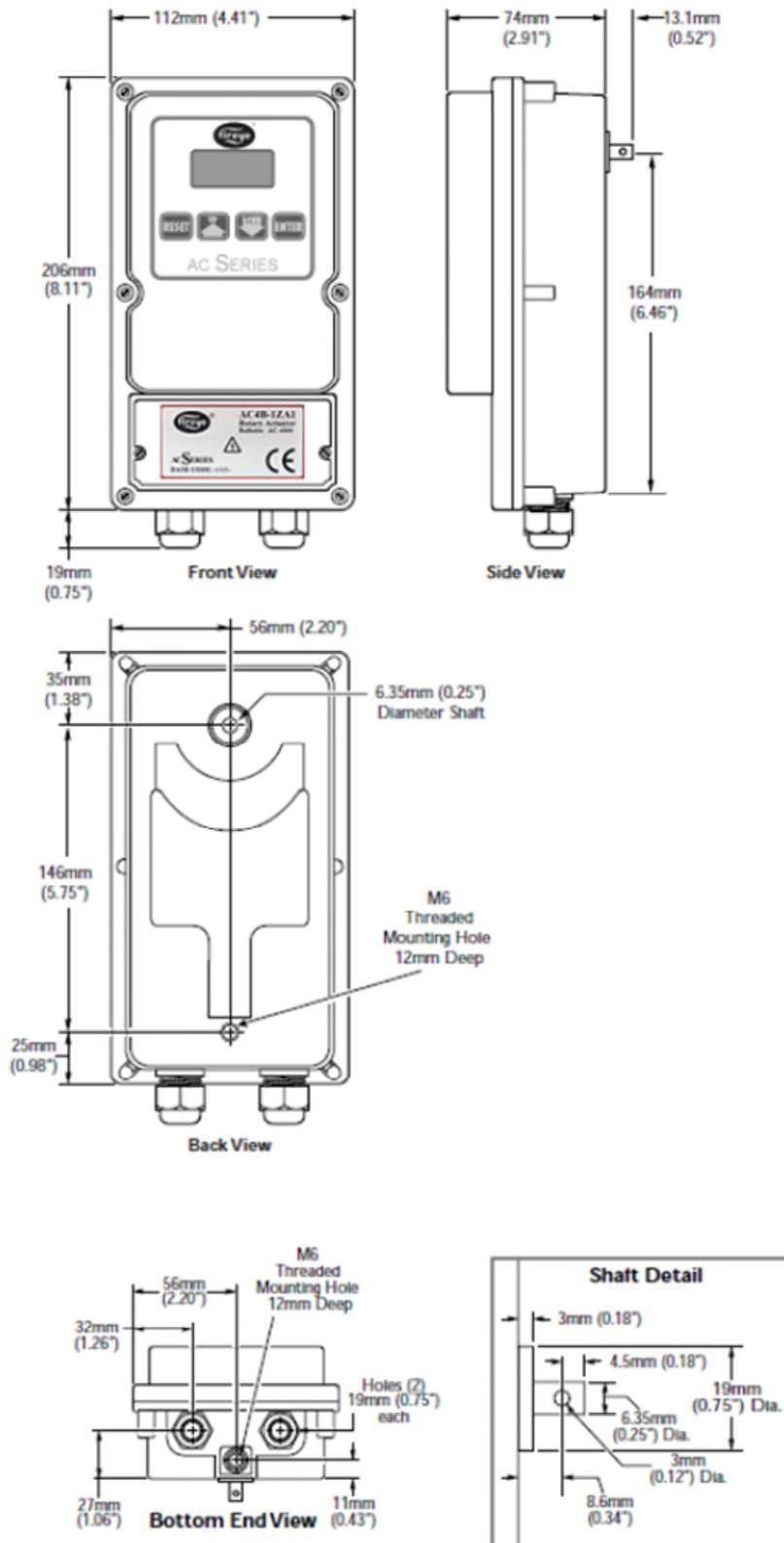

SAFETY ADVICE

Device Safety

Installation and maintenance must conform with the National Electrical Code and all other national and local codes and authorities having jurisdiction. The actuator must be installed by a qualified, licensed technician.

Make sure that the area is clean. Protect the actuator from the weather, damage, dirt and moisture. Protect the actuator from excessive temperatures and humidity. Take care not to hit or drop the actuator. Make sure that the actuator is clean and in good condition. After you have made sure that everything is present and in good condition, keep the actuator in the original package as long as possible. Store the actuator in a cool, clean, dry room.

The actuator must be used only for purposes corresponding to its construction and within the values specified in the technical data.

The installer should be satisfied that, as a result of the mounting, the commissioning or as a result of the test adjustments on the actuator, no potential hazards will be produced for devices/machines/ plant.

Before mounting the actuator, check the free movement of the valve/device.

After completing the mounting and adjustment, check the correct functioning of the actuator.

Safety advice for mounting and adjustments

The installer must be satisfied that, as a result of the commissioning or the test adjustments on the actuator, no potential hazards will be produced for personnel or the environment.

After completing adjustments check the correct functioning of the actuator.

Check the correct functioning of any safety devices.

Carry out adjustments only in accordance with the instructions described in this documentation.

Adjustments must therefore be carried out only by a licensed electrician or a qualified person having adequate training, who is aware of potential hazards.

Wiring

All of the electrical wiring must comply with one of the following standards:

- NFPA Standards 70
- ANSI-C11981
- EN60204-1
- the electrical wiring must be acceptable to the local authority having jurisdiction.

ACTUATOR DESCRIPTION

FIGURE 1. Coupler & Mounting Holes Location

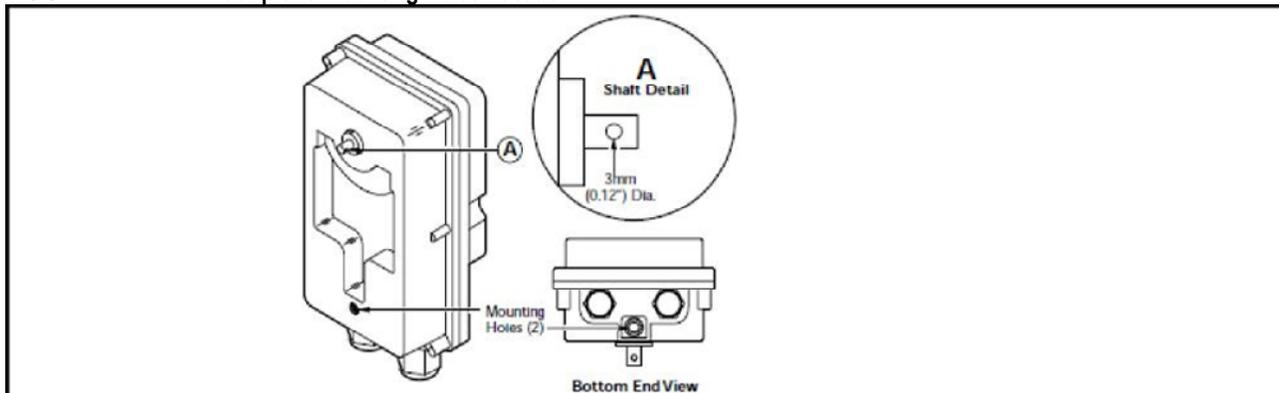



WARNING -

Local regulations may require guards and/or warnings when connecting the actuator to a component with linkage that could cause finger pinching. The actuator torque is: 2.3 N-m (20 lb-in).

INSTALLATION

ACTUATOR MOUNTING

Depending on your application, please keep the following in mind when mounting the actuator:

- The actuator housing has two mounting holes, as shown in Figure 1. Both holes are threaded and use M6 metric screws.
- Mounting this actuator depends on the application; contact Fireye for available mounting kits.
- When mounting the actuator, be certain that the actuator's drive shaft is properly aligned with the other shaft to which it will be coupled to avoid undue lateral stress.
- The actuator's drive shaft has a 3mm through hole for a coupler, as shown in Figure 1.
- Provide support for the weight of conduit or

CAUTION: Prevent water from condensation flowing into the actuator housing through the wiring conduits. Keep conduits oriented such that gravity will cause water to flow away from the actuator or provide a watertight seal in the conduit near the actuator.

ACTUATOR SHAFT TO BUTTERFLY VALVE COUPLING

Provide temporary power to the actuator and drive it to the minimum position (refer to "Power Supply" on the next page). Set the actuator's shaft rotation direction to match that of the butterfly valve; see page 22 to change the actuator's shaft direction if needed. Remove temporary power. Install the coupling to the actuator shaft. For couplings with a 3mm slotted spring pin, insert the coupling onto the shaft and align the coupling's drive hole with the shaft hole. Insert the spring pin through the coupling and shaft, being careful not to exert excessive stress on the shaft. Verify that the rotation direction of the butterfly valve and actuator shaft match (see step 2) while the butterfly valve is in its minimum position. Place the actuator in the orientation by which it will be attached to the mounting bracket. Slide the actuator and coupling assembly onto the butterfly valve shaft and attach carefully, taking precaution not to move the butterfly valve from its minimum position setting. Attach the mounting bolt through the bracket to the actuator; see Figure 1 on page 10 for the mounting hole locations. Confirm the position and tightness of all connections. Make all electrical connections and apply power. Verify that the stroke motion is smooth over its entire range. Refer to Section 3, "Parameter Selection", if adjustments are needed.

ACTUATOR WIRING

Access is through the two electrical connectors at the end of the actuator. Remove the front coverplate to access the terminal strips, as shown in Figure 2. Once the front coverplate is removed, the terminal strip on the left side (P2) is used for the power supply, and low and high fire auxiliary contacts. The terminal strip on the right side (P1) is used for the control signal inputs (4-20mA, 0-10V, etc.). To install a wire into a terminal, first strip the wire insulation back 1/4" (6mm), then press the tab back and hold while inserting the wire. Once the wire is in place, release the tab. Inspect the wire for loose strands and gently pull it to insure a secure connection. Use only one wire per terminal. Figure 3 on page 13 shows the wiring diagram for the actuator, while Figure 4 on page 14 shows a typical application.



FIGURE 2. Coverplate & Terminal Connections

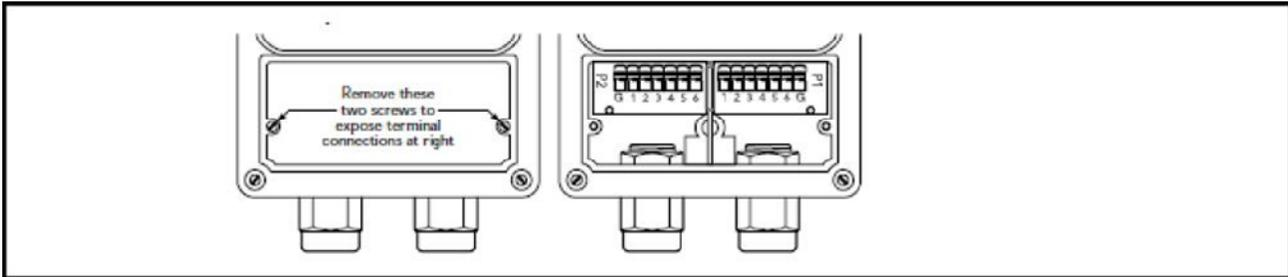

Power Supply

Connect the ground wire to P2-G, the neutral conductor to P2-1, and the “hot” or line voltage conductor to P2-2. Provide proper circuit protection (fuse or circuit breaker).

Auxiliary Contacts

The internal contacts are isolated and voltage free. Take care not to exceed the contact ratings listed in the specifications table on page xx. These contacts can be used for position detection. Connect an external supply to the common terminals, P2-3 and P2-5. Connect the external low position load to P2-6, and the external high position load to P2-4.

Low Fire Wiring

A switch or voltage-free contact can be wired between P1-5 (Low Fire) and P1-1 (GND) to move the actuator to the low fire position.

High Fire Wiring

A switch or voltage-free contact can be wired between P1-4 (High FIRE) and P1-1 (GND) to move the actuator to the high fire position.

Note: These digital signals override the 4-20mA and 0-10Vdc analog positioning signals.

Control Signal Wiring

Connect a 4-20mA signal positive (+) to P1-2 and negative (-) to P1-1 (GND). Or alternately connect a 0-10 Vdc signal positive (+) to P1-3 and negative (-) to P1-1 (GND). If both signals are connected, the greater value signal will determine the actuator’s position.

Disable Settings Wiring

After setting the parameters per Section3, connect P1- 6 (Auto/Man) to P1-1 (GND) to prevent inadvertent parameter changes through the keypad. With this jumper installed, pressing the ENTER key will display "LC" and not allow parameter changes.

FIGURE 3. Wiring Diagram for Actuator

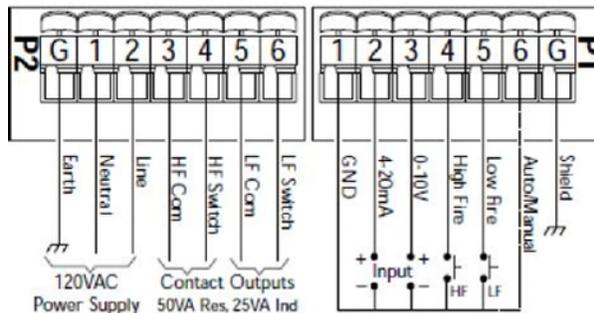



Note:

1. Separate low voltage signal wiring from high voltage signal wiring.
2. Control circuit wires must:
 - a) meet 90°C (194°F) specification minimum;
 - b) range from 22 to 14 AWG (.5 to 2.5mm²), and
 - c) be in accordance with all applicable codes.
3. Neutral must be grounded at its source.
4. Insert only one wire per terminal.
5. Provide power supply circuit protection.

FIGURE 4. Typical Application

Note: The following diagram is an example of how to use the actuator's various inputs and outputs. Some devices shown may be omitted or changed depending on your application.

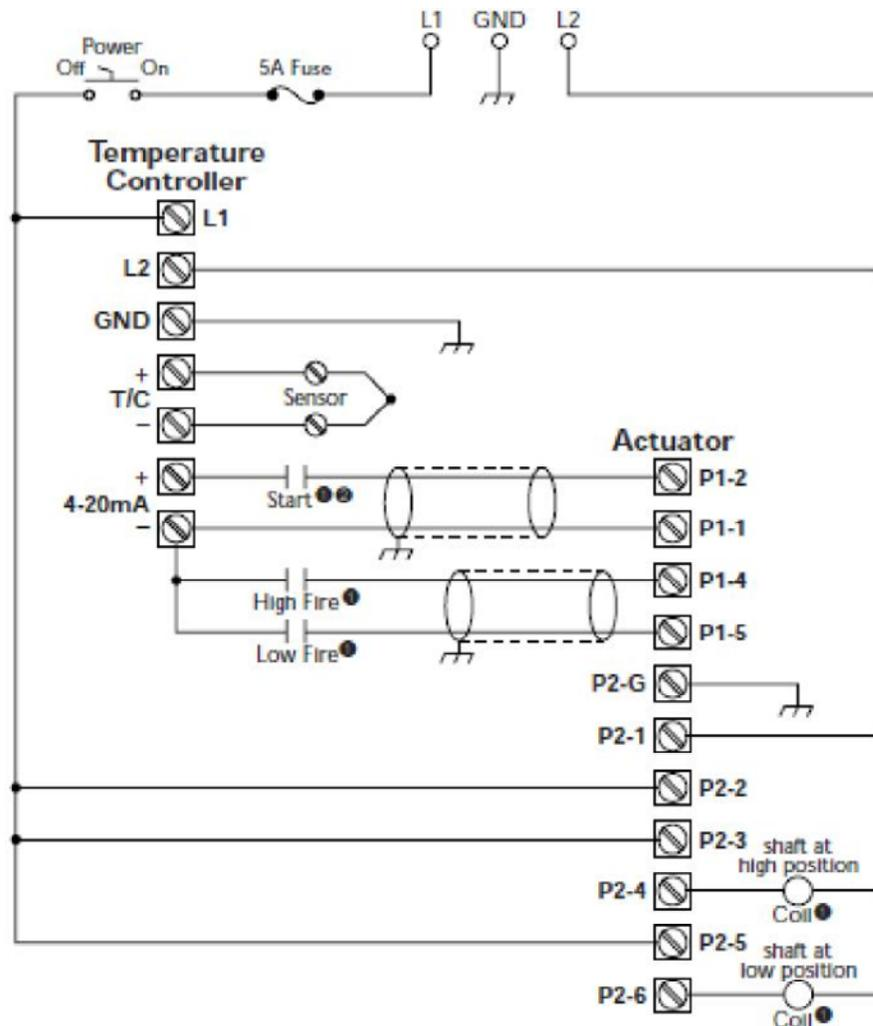

- 1 These components relate to burner sequence (not shown);
- 2 See "Control Signal Loss (LO)" on page 17.

Parameter Selection

In this section you will find the information about the various selectable parameters and how they can be programmed through the actuator's keyboard.

Low Fire Stop (LF)

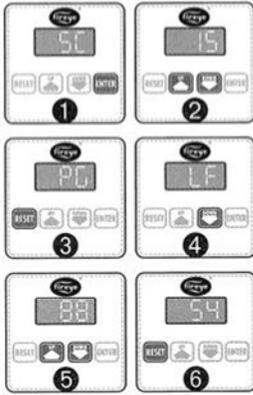

This parameter sets the minimum shaft travel position:

1. Press the ENTER key; the message "SC" will appear on the display.
2. Press either the UP or DOWN key until the number "15" appears on the display.
3. Press the RESET key; the message "LF" will appear on the display.
4. Press the DOWN key; the message "LF" will appear on the display.
5. Press either the UP or DOWN key until your desired number (the desired degree of shaft rotation) appears on the display
6. Press the RESET key to complete the sequence.

High Fire Stop (HF)



This parameter sets the highest shaft travel position:

1. Press the ENTER key; the message "SC" will appear on the display.
2. Press either the UP or DOWN key until the number "15" appears on the display.
3. Press the RESET key; the message "PG" will appear on the display.
4. Press the UP key; the message "HF" will appear on the display.
5. Press either the UP or DOWN key until your desired number (the desired degree of shaft rotation) appears on the display
6. Press the RESET key to complete the sequence.

Control Signal Loss (LO)

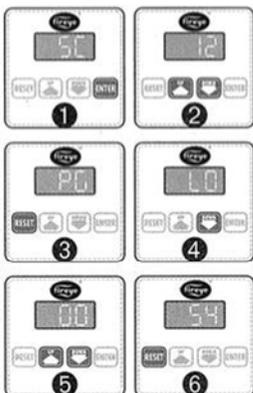

This parameter sets the position when the analog control signal is zero. It can be used to set a control valve at some intermediate position for burner start-up (see figure 4):

Note: Set LO to the same value as LF if you want the actuator to drive to the Low Fire Stop position (LF) when the control signal is zero.

1. Press the ENTER key; the message "SC" will appear on the display.
2. Press either the UP or DOWN key until the number "12" appears on the display.
3. Press the RESET key; the message "PG" will appear on the display.
4. Press the DOWN key; the message "LO" will appear on the display.
5. Press either the UP or DOWN key until your desired number (the desired degree of shaft rotation) appears on the display
6. Press the RESET key to complete the sequence.



Note: Please refer to Figure 5 for an illustration of the next four parameters

Low Fire Contact Release (LL)



This description of the contact state is for the normally open mode. As the shaft travels from high to low, the LL parameter sets where the low fire contact opens back up after having closed at the LS setting. For most applications, this value should be kept at zero (0). Set LF to 0 first if you need to set LL to 0.

1. Press the ENTER key; the message "SC" will appear on the display.
2. Press either the UP or DOWN key until the number "17" appears on the display.
3. Press the RESET key; the message "PG" will appear on the display.
4. Press the DOWN key; the message "LL" will appear on the display.
5. Press either the UP or DOWN key until your desired number (the desired degree of shaft rotation) appears on the display; this number must be of lesser value than the desired low fire contact sense (LS) number.
6. Press the RESET key to complete the sequence.

Low Fire Contact Sense (LS)

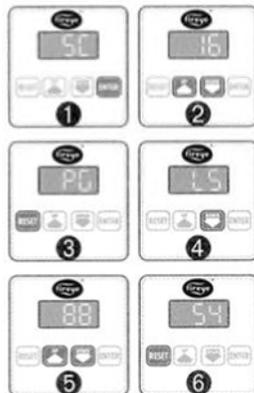

This description of the contact state is for the normally open mode. As the shaft travels from high to low, the LS parameter sets where the low fire contact closes. For most applications, this value should be kept at least five degrees above LF or LO, whichever is higher.

1. Press the ENTER key; the message "SC" will appear on the display.
2. Press either the UP or DOWN key until the number "16" appears on the display.
3. Press the RESET key; the message "PG" will appear on the display.
4. Press the DOWN key; the message "LS" will appear on the display.
5. Press either the UP or DOWN key until your desired number (the desired degree of shaft rotation) appears on the display; this number must be of greater value than the desired low fire contact release (LL) number.
6. Press the RESET key to complete the sequence.

High Fire Contact Sense (HS)



This description of the contact state is for the normally open mode. As the shaft travels from low to high, the HS parameter sets where the high fire contact closes. For most applications, this value should be kept at least five degrees below HF.

1. Press the ENTER key; the message "SC" will appear on the display.
2. Press either the UP or DOWN key until the number "16" appears on the display.
3. Press the RESET key; the message "PG" will appear on the display.
4. Press the DOWN key; the message "HS" will appear on the display.
5. Press either the UP or DOWN key until your desired number (the desired degree of shaft rotation) appears on the display; this number must be of lesser value than the desired high fire contact release (HH) number.
6. Press the RESET key to complete the sequence.



High Fire Contact Release (HH)

This description of the contact state is for the normally open mode. As the shaft travels from low to high, the HH parameter sets where the high fire contact opens back up after having closed at the HS setting. For most applications, this value should be kept at 90. Set HF to 90 first if you need to set HH to 90.



1. Press the ENTER key; the message "SC" will appear on the display.
2. Press either the UP or DOWN key until the number "17" appears on the display.
3. Press the RESET key; the message "PG" will appear on the display.
4. Press the UP key; the message "HH" will appear on the display.
5. Press either the UP or DOWN key until your desired number (the desired degree of shaft rotation) appears on the display; this number must be of greater value than the desired high fire contact sense (HS) number.
6. Press the RESET key to complete the sequence.

Note: In the following examples:

1. 0° and 90° represent the actuator shaft's range of travel rather than the shaft's alignment (therefore, 0° does not equal vertical and 90° does not equal horizontal).
2. The operating mode is normally open, HS and HH have been changed from the default setpoints shown on page xx. The set values are: LL=10, LS=20, HS=75 and HH=85.

FIGURE 5. Auxiliary Contact Positions in Relation to Shaft Rotation

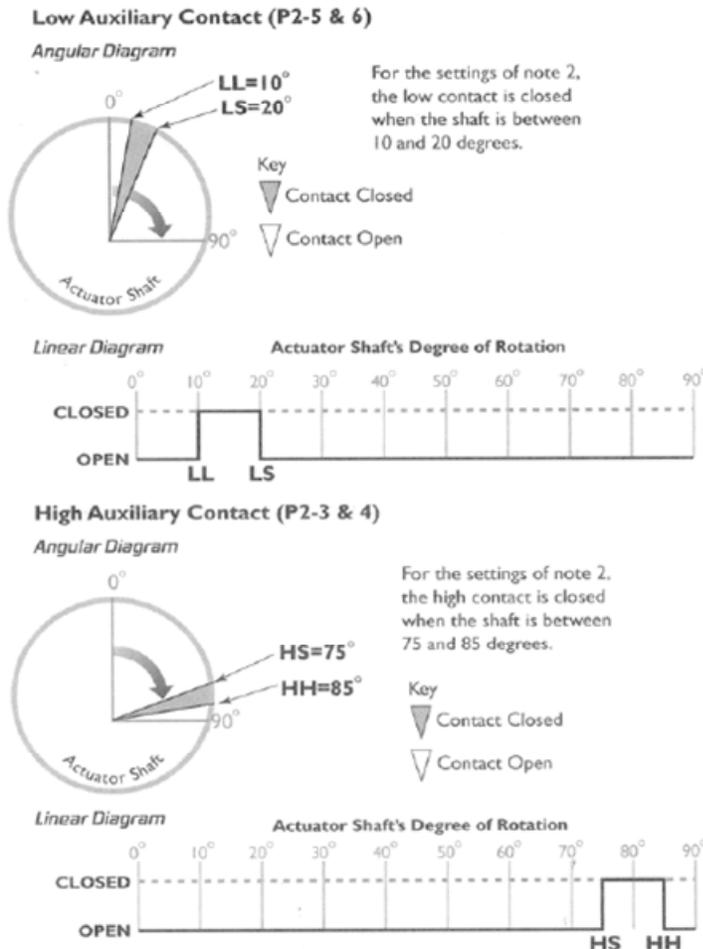

Manual Position Select



This parameter puts the actuator in the manual positioning mode. It allows the operator to manually position the shaft anywhere between low and high fire stop settings with the UP and DOWN keys:

1. Press the ENTER key; the message "SC" will appear on the display.
2. Press either the UP or DOWN key until the number "05" appears on the display.
3. Press the RESET key to complete the sequence.

Automatic Signal Input Select



This parameter takes the actuator out of the manual positioning mode. The shaft automatically positions at a point between low and high fires according to 4-20mA, 0-10Vdc or LF/HF inputs on the connector:

1. Press the ENTER key; the message "SC" will appear on the display.
2. Press either the UP or DOWN key until the number "06" appears on the display.
3. Press the RESET key to complete the sequence.

Auxiliary Contact Select - N.C.

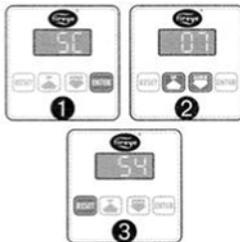

This parameter allows the operator to change the auxiliary contact from the normally open (NO) default to normally closed (NC):

1. Press the ENTER key; the message "SC" will appear on the display.
2. Press either the UP or DOWN key until the number "07" appears on the display.
3. Press the RESET key to complete the sequence.

Auxiliary Contact Select - N.O.



This parameter allows the operator to return the auxiliary contact's default setting to normally open (NO) if ever changed:

1. Press the ENTER key; the message "SC" will appear on the display.
2. Press either the UP or DOWN key until the number "08" appears on the display.
3. Press the RESET key to complete the sequence.



The next two parameters describe shaft rotation when facing the keypad.

Clockwise Rotation Select

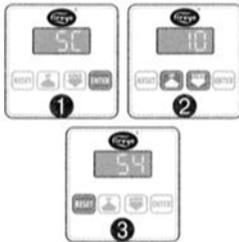

This parameter allows the shaft to travel clockwise when the input signal increases:

1. Press the ENTER key; the message “SC” will appear on the display.
2. Press either the UP or DOWN key until the number “10” appears on the display.
3. Press the RESET key to complete the sequence.

Counterclockwise Rotation Select

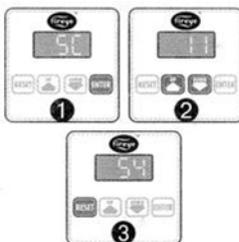

This parameter allows the shaft to travel counterclockwise when the input signal increases:

1. Press the ENTER key; the message “SC” will appear on the display.
2. Press either the UP or DOWN key until the number “11” appears on the display.
3. Press the RESET key to complete the sequence.

Examine Setpoints

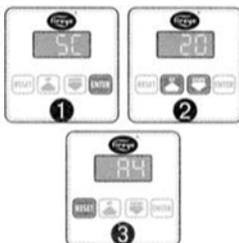

Pushing the RESET key twice allows the various setpoints to be examined. Once activated, the display will indicate a two-letter parameter code followed by its value in the following sequence:

- a. software version
- b. low fire stop position (LF)
- c. high fire stop position (HF)
- d. contact signal loss position (LO)
- e. low fire contact release position (LL)
- f. low fire contact sense position (LS)
- g. high fire contact sense position (HS)
- h. high fire contact release position (HH)
- i. manual (C5) or automatic (C6)
- j. aux. contact mode N.O. (C8) or N.C. (C7)
- k. rotation CW (C0) or CCW (C1)

The display will show each function’s setpoint for two seconds before scrolling to the next one.

Stalled Motor



If the motor is stalled for more than 30 seconds, the motor will stop and the display will indicate the percentage (%) sign.

Normal display and operation will resume automatically when the actuator is commanded to move in the opposite direction from the stall. To reverse direction while in the automatic mode, change either the analog input signal, apply a digital low fire or high fire input, or change to the manual mode. In some cases it may be necessary to disconnect the mechanical coupling to the valve.



Default Setpoints

This parameter resets the actuator to the default setpoints. The default setpoints are as follows:

- a. Automatic input signal
- b. Normally open (NO) contact
- c. Clockwise (CW) rotation
- d. 0° for LO, or control signal loss position
- e. 0° for LF, or low fire contact stop
- f. 0° for LL, or low fire contact release
- g. 5° for LS, or low fire contact sense
- h. 85° for HS, or high fire contact sense
- i. 90° for HH, or high fire contact release, and
- j. 90° for HF, or high fire contact stop

To reset the parameters to the default setting:

1. Press the ENTER key; the message “SC” will appear on the display.
2. Press either the UP or DOWN key until the number “20” appears on the display.
3. Press the RESET key to complete the sequence.

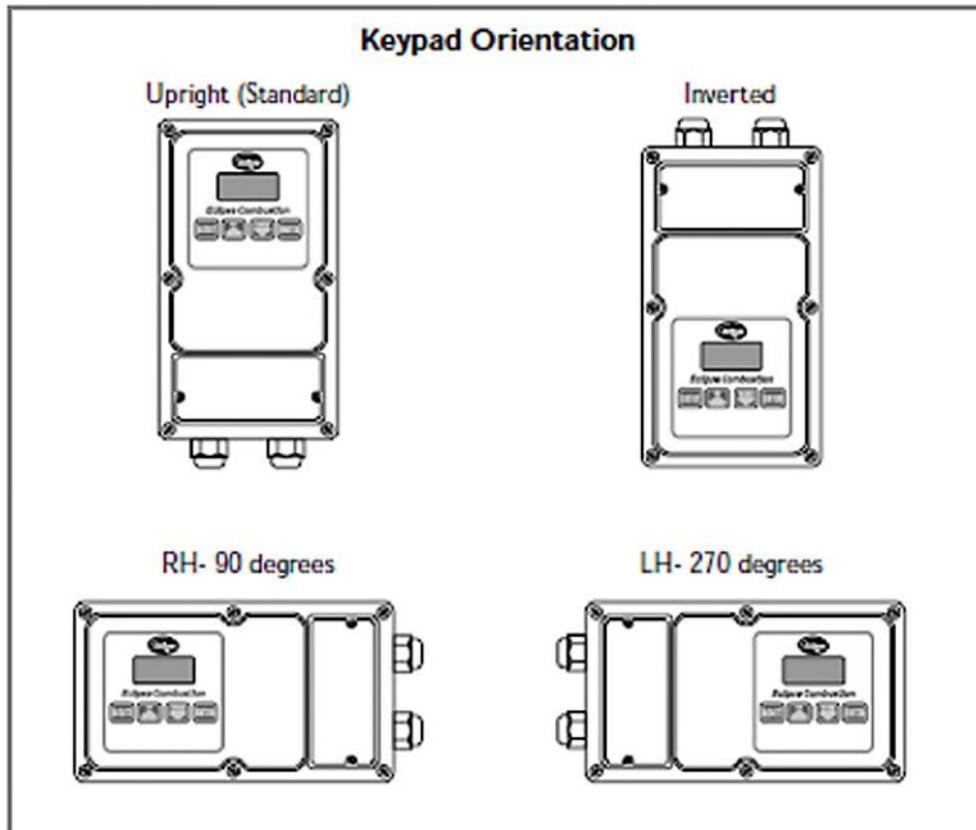



NOTICE

When Fireeye products are combined with equipment manufactured by others and/or integrated into systems designed or manufactured by others, the Fireeye warranty, as stated in its General Terms and Conditions of Sale, pertains only to the Fireeye products and not to any other equipment or to the combined system or its overall performance.

WARRANTIES

FIREYE guarantees for *one year from the date of installation or 18 months from date of manufacture* of its products to replace, or, at its option, to repair any product or part thereof (except lamps and photocells) which is found defective in material or workmanship or which otherwise fails to conform to the description of the product on the face of its sales order. **THE FOREGOING IS IN LIEU OF ALL OTHER WARRANTIES AND FIREYE MAKES NO WARRANTY OF MERCHANTABILITY OR ANY OTHER WARRANTY, EXPRESS OR IMPLIED.** Except as specifically stated in these general terms and conditions of sale, remedies with respect to any product or part number manufactured or sold by Fireeye shall be limited exclusively to the right to replacement or repair as above provided. In no event shall Fireeye be liable for consequential or special damages of any nature that may arise in connection with such product or part.