



P-C II

ULTRA-VIOLET SCANNER

- High flame signal
- Can be mounted in any position
- Encapsulated sensor tube permanently sealed in gas tight housing
- Operates with gas and/or oil flames



IRI ACCEPTED

SPECIFICATIONS

Ambient temperature:
Minus 20° to 212°F (100°C)

Nominal operating voltage:
590V 60Hz from PROTECTOFIER
UV terminal to ground

Peak spectral light response:
210 Nanometers (2100 Angstroms)

P-C II ULTRA-VIOLET SCANNERS

Can be used with any flame which contains ultra-violet. Flame electrodes and P-C II SCANNERS can be used simultaneously in the same PROTECTOFIER system. Compact units contain an ultra-violet sensing tube for direct 2-wire connection to PROTECTOFIER.



P-C II—provided with an electrical connector for flexible metal conduit (3/8" max.)



P-C II W—provided with 1/2" straight liquid-tite electrical connector



P-C II WRA—provided with a 1/2" right angle liquid-tite electrical connector

MADE IN U.S.A.



PROTECTION CONTROLS, INC.

ELECTRICAL SAFETY EQUIPMENT

7317 N. LAWDALE AVENUE
P.O. BOX 287 • SKOKIE, ILLINOIS 60076-0287
(847) 674-7676 • CHICAGO PHONE: (773) 763-3110
FAX: (847) 674-7009
e-mail@protectioncontrolsinc.com
www.protectioncontrolsinc.com

P-C II U-V SCANNER

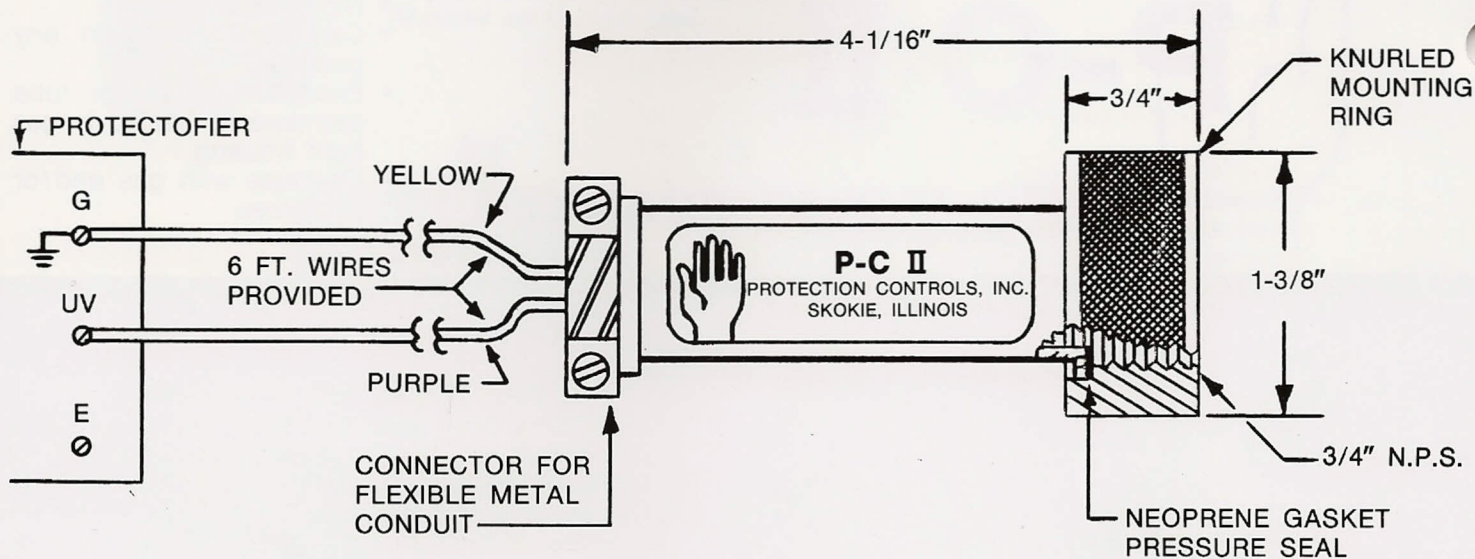

P-C II W — With 1/2" straight liquid-tite connector — add 1/2" to total length.

P-C II WRA — With 1/2" right angle liquid-tite connector — add 1 1/2" to total length.

P-C II U-V SCANNER INSTALLATION INSTRUCTIONS

1. The P-C II U-V SCANNER shall be connected to the PROTECTOFIER Combustion Safeguard only.
 - a. Purple lead wire connects to U-V terminal on PROTECTOFIER.
 - b. Yellow lead wire connects to system ground. (Only one ground wire is required for any number of sensors.)
2. The P-C II U-V SCANNER must be positioned so it will sight at a point where the pilot flame at its minimum setting will reliably light the main burner flame.
3. The P-C II U-V SCANNER shall be shielded mechanically or electrically from spark excitation as well as from any other ultra-violet source.
4. Do not use a wrench on the housing or put strain on the housing when making flexible metal conduit connection as this can result in damage to the scanner. The flexible metal connection should be made prior to mounting the scanner on the burner. **The electrical connector is not to be removed.**
5. It is recommended that the P-C II U-V SCANNER be replaced at approximately 8000 hours of operation. Adverse operating conditions such as elevated temperatures and high operating voltages will require more frequent replacement.
6. The control system must be thoroughly checked periodically * for proper operation by duplicating flame failure at each flame position to verify proper response to loss of flame signal.
7. Periodic cleaning of the P-C II U-V SCANNER tube is necessary to maintain highest signal strength.

*INSTALLATION, OPERATION AND MAINTENANCE SHALL CONFORM WITH NATIONAL FIRE PROTECTION ASSOCIATION STANDARDS, NATIONAL AND LOCAL CODES, AND AUTHORITIES HAVING JURISDICTION. ANY MODIFICATION VOIDS APPROVALS.

P-C II U-V SCANNER

with optional accessories
applied to a burner

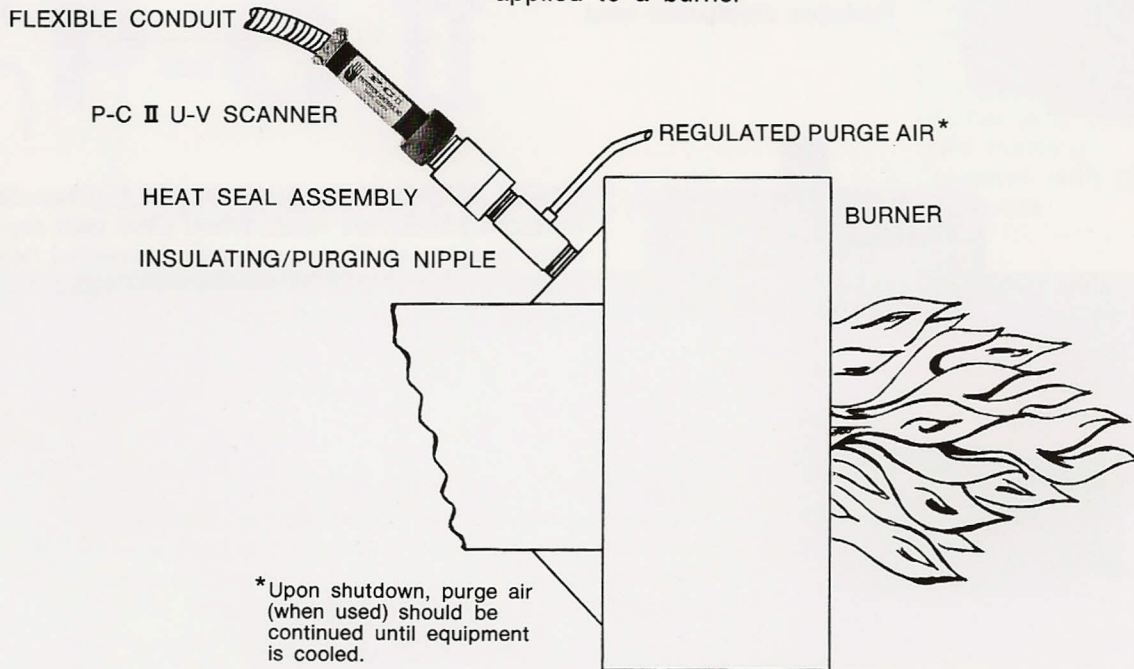

FLAME SENSOR WIRE INSTALLATION INSTRUCTIONS

Both proper wire selection and routing are essential to the reliable operation of the combustion safeguard.

The wire must be rated for a minimum of 600V and for the maximum ambient temperature. Sensor wire may be either solid or stranded and should be plastic insulated such as TW, TH, THHN, or MTW. Number 14 AWG wire is normally used - minimum wire size is 18 AWG. Heavier wire may produce a slightly higher micro-ampere reading. Cloth, rubber, or asbestos insulated wire, microphone cable, twisted pairs, and multi-conductor cables should not be used due to their contaminant absorption and/or capacitance characteristics. The wire should not be spliced nor should pulling compound be used.

Flame sensor wire lengths less than 50 feet may be combined with nominal amperage 115V 60 Hz control wiring. Wire lengths over 50 feet should be run in a separate conduit. Wire lengths exceeding 150 feet are not recommended although lengths in excess of 250 feet have been used successfully. If lead lengths are over 150 feet, moving the combustion safeguard closer to the burner is recommended. If distances over 150 feet cannot be avoided, a low capacitance shielded cable such as RG62AU should be used. This cable is available — see Price Bulletin PAR. The maximum distance between the flame sensor and the combustion safeguard depends upon burner adjustment, sensor, routing, wire and external sources of interference.

RG62AU COAXIAL SHIELDED CABLE

Flame sensor wire acts like a capacitor to the conduit which reduces the sensor operating voltage and lowers the returned signal. The lower the capacitance of the wire, the better the signal that can be returned to the flame safeguard. To achieve maximum distance, the shield of the RG62AU cable should be floating (not grounded) at both ends. To minimize external coupling interference, the shield should be grounded at both ends although this will reduce the lead length that can be satisfactorily run.

External electromagnetic radiation will adversely affect operation of the flame sensor and combustion safeguard. Sensor wire must never be run with power wiring such as motor control, high voltage wiring such as ignition transformers or direct current wiring such as SCR motor control, proportional motors and thermocouple wires. Conduit should be routed away from high current devices such as motors, transformers or buss bars, especially if they have a direct current component. Sensor wire must be kept away from induction furnaces and powerful R.F. transmitters.

P-C II U-V SCANNER ACCESSORIES



FIBER INSULATOR (Phenolic)
Reduces conducted heat.

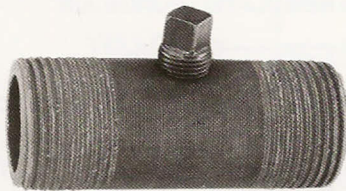

INSULATING/PURGING NIPPLE (Phenolic)
Reduces conducted heat. When used with regulated purging air it also reduces convected heat. Supplied with $\frac{1}{8}$ " N.P.T. tapped hole and plug to receive purge air connection.



HEAT SEAL ASSEMBLY
Reduces conducted, convected and radiated heat. Available with plain or magnifying quartz lens. Magnifying quartz lens will increase signal strength.*

HEAT SEAL ASSEMBLY FOR P-C II U-V SCANNER

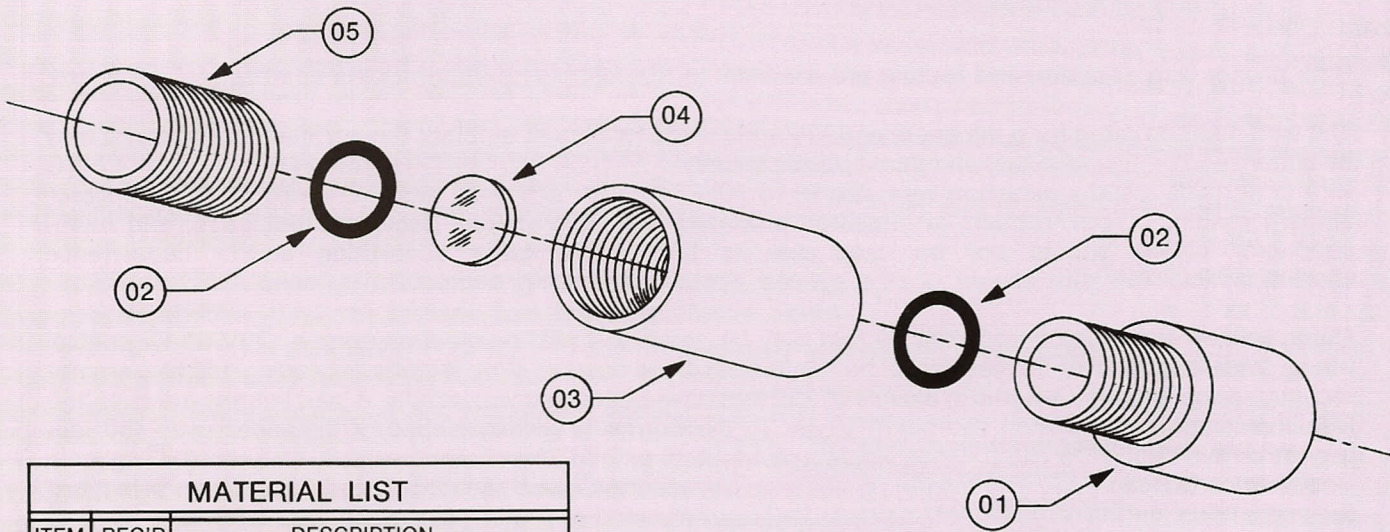

MATERIAL LIST		
ITEM	REQ'D	DESCRIPTION
01	1	FIBER INSULATOR - $\frac{3}{4}$ "N.P.S.
02	2	NEOPRENE WASHER
03	1	HEAT SEAL THREADED SLEEVE $1\frac{1}{8}$ "LONG- $\frac{3}{4}$ "N.P.S.
04	1	QUARTZ LENS*
05	1	QUARTZ LENS RETAINING NIPPLE ($\frac{3}{4}$ "N.P.S. CLOSE NIPPLE)

* PLAIN OR MAGNIFYING LENS AVAILABLE. MAGNIFYING LENS NOT RECOMMENDED FOR INSTALLATION WHERE P-C II IS LESS THAN 10 INCHES FROM FLAME.

