

Model 121 Regulators

Installation and Maintenance Instructions

Introduction

The Model 121 Regulator represents a combination of capacity, performance and value — Streamlined body passages provide large capacity. **An external control line is required from lower case to control piping.** The 121 has a fast speed of response, yet is stable in operation. Soft seats assure positive tight shutoff. Orifices are replaceable. Springs are color coded. It is also available as a zero governor or atmospheric regulator, a relief valve or backpressure regulator, and a vacuum regulator or vacuum breaker.

Installation

1. Examine the regulator for shipping damage.
2. Check nameplate data. Be sure regulator conforms with what was ordered.
3. Inside of regulator and piping must be clean and free of dirt. Remove all dirt and debris before installing regulator. Failure to remove dirt/debris could result in regulator damage or trouble.
4. Remove all shipping screens and covers from the regulator. Do not let dirt get inside the regulator.
5. Install the regulator. Make sure the inlet and outlet are correctly connected. High pressure connects to the inlet. The flow arrow must point downstream.
6. Screwed connections must conform with good piping practice free of excess thread engagement per ANSI B2.1. Apply pipe joint compound to male threads only.
7. The model 121 Regulator is usually right side-up as shown on the Typical Installation drawing (See Page 2.) It may, however, be installed upside down. When inverted it may be necessary to readjust the set-point.

Caution: Do not install sideways. The diaphragm should be horizontal.

8. Install the control line. Connect it into the outlet piping at least 8-10 pipe diameters downstream from the regulator.

Cautions:

- a. On backpressure regulators and relief valves the external control line connects into the **inlet** piping, 5 pipe diameters upstream from the regulator.
- b. Do not install any automatic shutoff device that closes completely between the regulator and the control line connection into the piping.

To avoid excessive turbulence, the connection should be clean and smooth on the inside and be located in straight pipe clear of valves and fittings. Keep the inside of the control line clean and protect it from corrosion. Pitch it away from the regulator and avoid moisture pockets. It must be strong (1/4" for 121-8 and 121-12, 1/2" for 121-16, or larger steel tubing or pipe is preferred). It must be well protected against breakage.

Regulator will open wide if the control line breaks.

9. On indoor installations requiring venting outdoors, run the vent piping as short and direct as possible with minimum bends and elbows. Use the same size or larger pipe as the vent connections on the regulator. With natural gas, or any other hazardous gas, vent to a safe place outdoors in case gas should accidentally be discharged. Screen and protect the opening outdoors to guard against water, ice, dirt, debris or insects.

10. Make sure the regulator is correctly connected and adequately supported. Ensure all pipe joints are tight.

Start-Up

- A. The inlet and outlet shutoff valves should both be closed. If a by-pass is used, the by-pass valve should also be closed.
- B. Note the set-point (set-point is the outlet pressure the regulator is adjusted to deliver). Regulator is factory adjusted to the set-point specified on the order.

Caution: This caution applies where the piping downstream of the outlet shutoff valve is pressured. That pressure must not exceed the regulator set-point by more than the pressure noted (see "Maximum Emergency Pressures", Page 21).

- C. **Slowly** and carefully open the **inlet** shutoff valve just enough to allow **inlet pressure** to build up slowly in the regulator until it is fully pressured.

Caution: During start-up a pressure gauge must be used on the regulator **outlet** pressure and carefully watched. While **inlet** pressure builds up, **outlet** pressure must not exceed set-point by more than 1 psi. If **outlet** pressure begins to exceed set-point by more than 1 psi, close the **inlet** shutoff valve. This indicates the regulator is not closing properly. Check and make necessary corrections before proceeding with start-up. If regulator **outlet** pressure exceeds set-point by more than the pressure noted, refer to "Maximum Emergency Pressures", Page 21 for instructions.

- D. Check installation for leaks.
- E. **Slowly** open the outlet shutoff valve to allow a small flow (approximately 1000 SCFH). Make sure the flow of gas does not create a hazard.
NOTE: If piping downstream of outlet shutoff valve is pressured, see "**Caution**" under B.
- F. With gas flowing, check for correct inlet and outlet pressures. It may be necessary to further open the inlet shutoff valve to maintain full inlet pressure.
- G. Make sure the regulator closes tight (tight lock-up). To do this, reduce flow to zero by slowly closing the outlet shutoff valve. Outlet pressure should not exceed set-point by more than 6" w.c.
- H. Fully open inlet and outlet shutoff valves slowly and carefully. Watch pressure gauges.
- I. Complete start-up by making sure there are no leaks.

NOTE

Do not exceed the regulator's pressure ratings. The regulator outlet has a lower pressure rating than the inlet. Do not expose the regulator outlet or control line to inlet pressure.

Regulator with external control may be used as an upstream monitor or upstream regulator in a monitor set. The control line must connect into the outlet piping downstream of the downstream regulator.

If the regulator is to be moved to another location, make sure its construction is compatible with the pressure and flow conditions.

Temperature Limits

The Model 121 Regulator can be used for flowing temperatures from -20°F to 150°F.

Buried Service

The Model 121 Regulator is not recommended for buried service.

Set-Point Adjustment (see parts diagrams on pages 5 & 6)

- A. The 121 is factory adjusted as specified on the order. To change the set-point, readjust as follows:
1. Remove top cap 1.
 2. Adjust set-point with adjustment button 3 or 3a. Turn clockwise to increase and counterclockwise to decrease the outlet pressure.

NOTE:

- a. Only make this adjustment when gas is actually flowing through the regulator. The flow should be small (approximately 1000 SCFH). Do not adjust when the regulator is closed and there is no flow.
 - b. Do not increase the set-point beyond the upper limit of the outlet pressure range for the spring 9 (refer to spring tables, Page 3).
 - c. Always check the outlet pressure with a pressure gauge while adjusting the set-point.
3. When adjustment is complete, replace top cap 1. Screw it securely into place. Failing to replace cap could cause unstable regulator operation.

CAUTION

It is the user's responsibility to assure that all regulator vents and/or vent lines exhaust to a non-hazardous location away from ANY POTENTIAL sources of ignition. Where vent lines are used, it is the user's responsibility to assure that each regulator is individually vented and that common vent lines ARE NOT used.

To Change Spring (see parts diagrams on pages 5 & 6)

The outlet pressure ranges of spring 9 are given in the tables on Pages 3 and 4.

1. Remove top cap 1.
2. Unscrew and remove adjustment button 3 or 3a by turning counterclockwise, and remove spring 9.
3. Insert new spring. Make sure it is positioned correctly at the bottom before replacing adjustment button 3 or 3a.
4. Adjust for the desired outlet pressure per previous section "Set-Point Adjustment."

Typical Installation

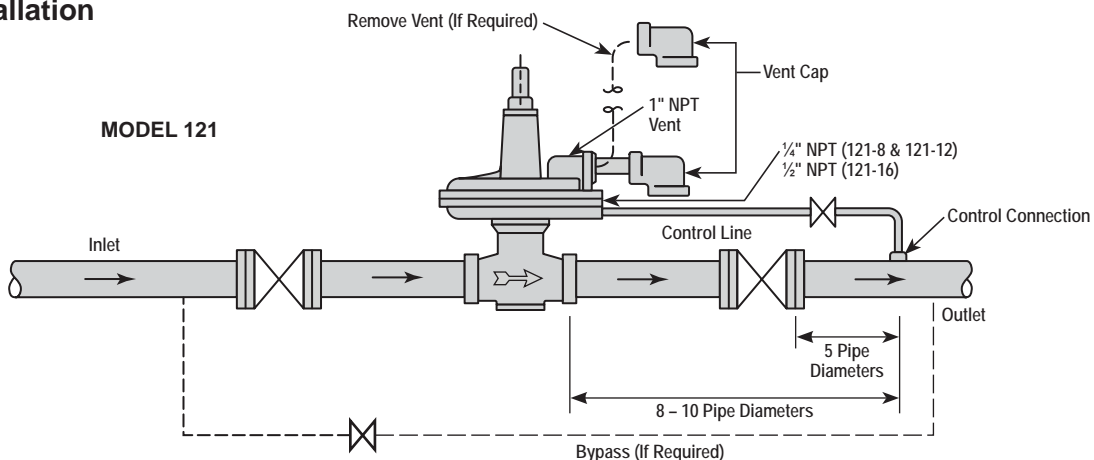

5. When adjustment is complete, replace top cap 1. Screw it securely into place. Failing to replace cap could result in unstable regulator operation.
6. New spring range should be marked on regulator. If old spring range appears on regulator, it should be removed.

CAUTION

The diaphragm case vent must be positioned to protect against flooding, drain water, ice formation, traffic, tampering, etc. The vent must be protected against nest building material, bees, insects, etc. to minimize the chances for foreign material from collecting in the vent side of the regulator diaphragm.

Shutdown

Shutdown and take the regulator out of service: 1. Carefully close the inlet stop valve. 2. Close the outlet stop valve. Before working on regulator, read the next section "General Servicing Instructions" and the applicable servicing instructions.

CAUTION

Turn gas on very slowly. If an outlet stop valve is used, it should be opened first. Do not overload diaphragm with a sudden surge of inlet pressure. Monitor the outlet pressure during start-up to prevent an outlet pressure overload.

General Servicing Instructions

- A. Before any disassembly of the regulator, ensure it is completely depressured. Pressure must be fully released from the inlet, the outlet and the control line connection. Failure to adequately depressure could result in serious personal injury.
- B. Carefully note the location and position of all disassembled parts to be certain reassembly is correct. Inspect each part carefully and replace any that are worn, damaged or otherwise unsatisfactory.
- C. Upon completion of servicing, make certain the regulator installation is entirely free of leaks.

CAUTION

Regulators are pressure control devices with numerous moving parts, subject to wear and dependent upon particular operating conditions. To assure continuous satisfactory operation, a periodic inspection schedule must be adhered to with the frequency of inspection determined by the severity of service and applicable laws and regulations.

Outlet Pressure Ranges and Springs

Size	Outlet Pressure Range	Spring Color	Spring Part Number	Maximum Inlet Pressure	Nominal Diaphragm Size
3/4", 1" and 1 1/4" ** Model 121-8	1 1/2" to 3 1/2" w.c.	Blue-Black	143-82-021-01 (main spring)	60 psi	8"
	1 1/2" to 3 1/2" w.c.	Black-Red	121-10-021-50 (counterspring)		
	1 1/2" to 12" w.c.	Green-Black	143-82-021-02 (main spring)		
	1 1/2" to 12" w.c.	Black-Red	121-10-021-50 (counterspring)		
	3 1/2" to 6 1/2" w.c.	Red-Black	143-82-021-00		
	5" to 8 1/2" w.c.	Blue-Black	143-82-021-01		
	6" to 14" w.c.	Green-Black	143-82-021-02		
	12" to 28" w.c.	Green (2" O.D.)	143-16-021-05		
	1 psi to 2 psi	Orange (2" O.D.)	143-16-021-06		
	2 psi to 4 1/4 psi	Black	143-16-021-07		
3/4", 1" and 1 1/4" ** Model 121-8HP	3 psi to 6 1/2 psi	Cadmium*	143-16-021-08	60 psi	8"
	6 psi to 10 psi	Cadmium*	143-16-021-08 (outer)		
	6 psi to 10 psi	White	143-16-021-13 (inner)		
1 1/2", 2" and 2 1/2" Model 121-12	1 1/2" to 3 1/2" w.c.	Red	143-16-021-03 (main spring)	60 psi	12"
	1 1/2" to 3 1/2" w.c.	—	120-10-021-10 (counterspring)		
	1 1/2" to 12" w.c.	Maroon	121-42-021-00 (main spring)		
	1 1/2" to 12" w.c.	—	120-10-021-10 (counterspring)		
	3 1/2" to 6 1/2" w.c.	Red (2" O.D.)	143-16-021-03		
	5" to 8 1/2" w.c.	Blue (2" O.D.)	143-16-021-04		
	6" to 14" w.c.	Green (2" O.D.)	143-16-021-05		
	12" to 28" w.c.	Orange (2" O.D.)	143-16-021-06		
	1 psi to 2 psi	Black	143-16-021-07		
	1 1/2 psi to 3 psi	Cadmium	143-16-021-08		
1 1/2", 2" and 2 1/2" Model 121-8	1 psi to 2 psi	Orange (2" O.D.)	143-16-021-06	60 psi	8"
	2 psi to 4 1/4 psi	Black	143-16-021-07		
1 1/2", 2" and 2 1/2" Model 121-8HP	3 psi to 6 1/2 psi	Cadmium*	143-16-021-08	60 psi	8"
	6 psi to 10 psi	Cadmium*	143-16-021-08 (outer)		
	6 psi to 10 psi	White	143-16-021-13 (inner)		
3" and 4" Model 121-16	3 1/2" to 6 1/2" w.c.	Red (3" O.D.)	121-62-021-50	15 psi (4" 121) 40 psi (3" 121)	16"
	5" to 8 1/2" w.c.	Blue (3" O.D.)	121-62-021-51		
	6" to 14" w.c.	Green (3" O.D.)	121-62-021-52		
	14" to 28" w.c.	Orange (3" O.D.)	121-62-021-53		
	1/2 psi to 1 1/4 psi	Yellow	121-62-021-56		
3" and 4" Model 121-12	1 psi to 2 psi	Black	143-16-021-07	15 psi (4" 121) 40 psi (3" 121)	12"
	1 1/2 psi to 3 psi	Cadmium	143-16-021-08		

* Requires High Pressure Spring Adjustment.

** 3/4" x 3/4" not available.

Atmospheric Regulator or Zero Governor

Size	Outlet Pressure Range	Spring
3/4", 1" and 1 1/4" Model 121-8	1 1/2" w.c. vacuum (-1 1/2" w.c.) to + 1 1/2" w.c.	Main Spring (Red-Black) Counterspring (Black-Red)
1 1/2", 2" and 2 1/2" Model 121-12	1" w.c. vacuum (-1" w.c.) to + 1 1/2" w.c.	Main Spring (Red-Black) Counterspring
3" and 4" Model 121-16	1 1/4" w.c. vacuum (-1 1/4" w.c.) to + 1 1/4" w.c.	Main Spring only

Differential Regulator

Size	Differential Pressure Range	Spring Color	Spring Part Number	Maximum Body Pressure	Maximum Diaphragm Pressure Differential	Maximum Diaphragm Case Pressure
¾", 1" and 1¼" Model 121-8*	3½" to 6½" w.c.	Red-Black	143-82-021-00	60 psi	2 psi	35 psi
	5" to 8½" w.c.	Blue-Black	143-82-021-01			
	6" to 14" w.c.	Green-Black	143-82-021-02			
	12" to 28" w.c.	Green	143-16-021-05			
	1 psi to 2 psi	Orange (2" O.D.)	143-16-021-06			
1½", 2" and 2½" Model 121-12	3½" to 6½" w.c.	Red (2" O.D.)	143-16-021-03	60 psi	2 psi	20 psi
	5" to 8½" w.c.	Blue (2" O.D.)	143-16-021-04			
	6" to 14" w.c.	Green (2" O.D.)	143-16-021-05			
	12" to 28" w.c.	Orange (2" O.D.)	143-16-021-06			
	1 psi to 2 psi	Black	143-16-021-07			
3" and 4" Model 121-16	3½" to 6½" w.c.	Red (3" O.D.)	121-62-021-50	15 psi (4" 121)	1 psi	10 psi
	5" to 8½" w.c.	Blue (3" O.D.)	121-62-021-51	40 psi (3" 121)		
	6" to 14" w.c.	Green (3" O.D.)	121-62-021-52			
	12" to 28" w.c.	Orange (3" O.D.)	121-62-021-53			
3" and 4" Model 121-12	1 psi to 2 psi	Black	143-16-021-07	15 psi (4" 121)	2 psi	20 psi
	1½ psi to 3 psi	Cadmium	143-16-021-08	40 psi (3" 121)		

* ¾" x ¾" not available.

Back Pressure Regulator or Relief Valve

Size	Relief or Back Pressure Range	Spring Color	Part Number	Maximum Diaphragm Case Pressure
¾" thru 2½" Model 121-8*	3" to 5½" w.c.	Red-Black	143-82-021-00	10 psi
	5" to 7½" w.c.	Blue-Black	143-82-021-01	
	6" to 13" w.c.	Green-Black	143-82-021-02	
	10" to 15" w.c.	Blue (2" O.D.)	143-16-021-04	
	12" to 25" w.c.	Green (2" O.D.)	143-16-021-05	
	18" w.c. to 2 psi	Orange (2" O.D.)	143-16-021-06	
	1 psi to 4 psi	Black	143-16-021-07	
¾" thru 2½" Model 121-8**	3 psi to 6 psi	Cadmium**	143-16-021-08	20 psi
	6 psi to 10 psi	Cadmium (outer)**	143-16-021-08	
	6 psi to 10 psi	White (inner)	143-16-021-13	
1½", 2" and 2½" Model 121-12	3" to 5½" w.c.	Red (2" O.D.)	143-16-021-03	10 psi
	5" to 7" w.c.	Blue (2" O.D.)	143-16-021-04	
	6" to 12" w.c.	Green (2" O.D.)	143-16-021-05	
	12" to 25" w.c.	Orange (2" O.D.)	143-16-021-06	
1½" thru 4" Model 121-12	20" w.c. to 1¼ psi	Black	143-16-021-07	10 psi
	1½ to 2¾ psi	Cadmium	143-16-021-08	
3" and 4" Model 121-16	3" to 4½" w.c.	Red (3" O.D.)	121-62-021-50	5 psi
	3" to 6" w.c.	Blue (3" O.D.)	121-62-021-51	
	5" to 11" w.c.	Green (3" O.D.)	121-62-021-52	
	10" to 24" w.c.	Orange (3" O.D.)	121-62-021-53	
	14" w.c. to 1¼ psi	Yellow	121-62-021-56	

* Requires High Pressure Spring Adjustment (121-8HP).

** ¾" x ¾" not available.

3/4" - 1" - 1 1/4"
Standard, Differential, Atmospheric or Zero Governors

Pipe Sizes (Inlet x Outlet) Screwed, NPT
3/4" x 1"
3/4" x 1 1/4"
1" x 1"
1" x 1 1/4"
1 1/4" x 1 1/4"

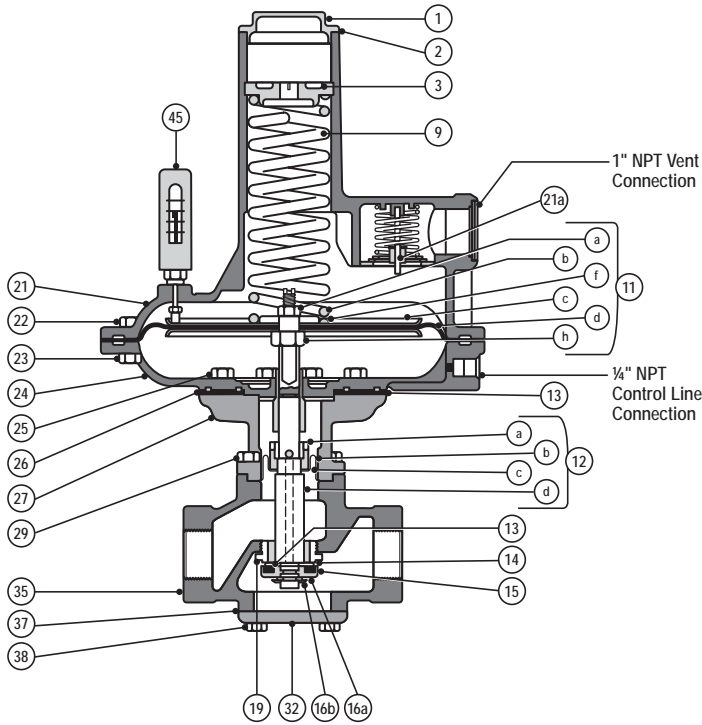

GIM1328-010

121-8 - STANDARD

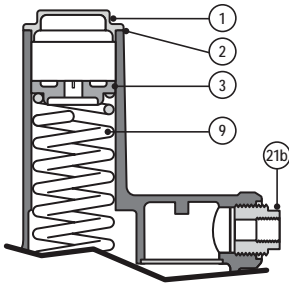

GIM1328-015

Fig. 1
Adjustment and Vent Connection
 21b for Differential Regulators,
 Atmospheric Regulators and
 Zero Governors

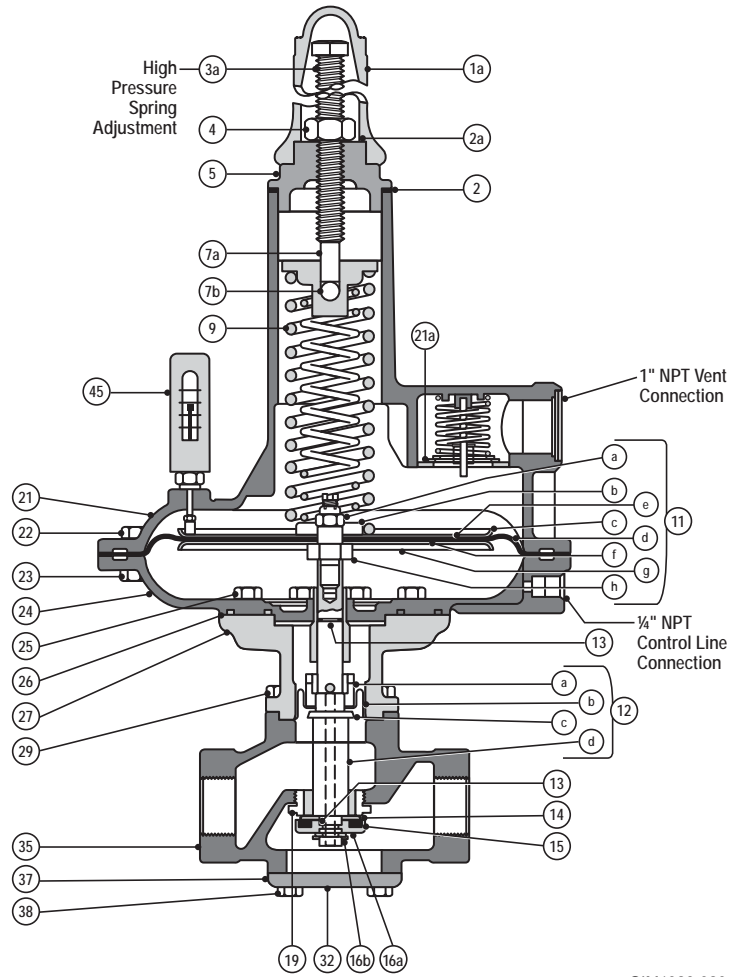

GIM1328-020

121-8 HP - HIGH PRESSURE

**3/4" – 1" – 1 1/4"
Back Pressure**

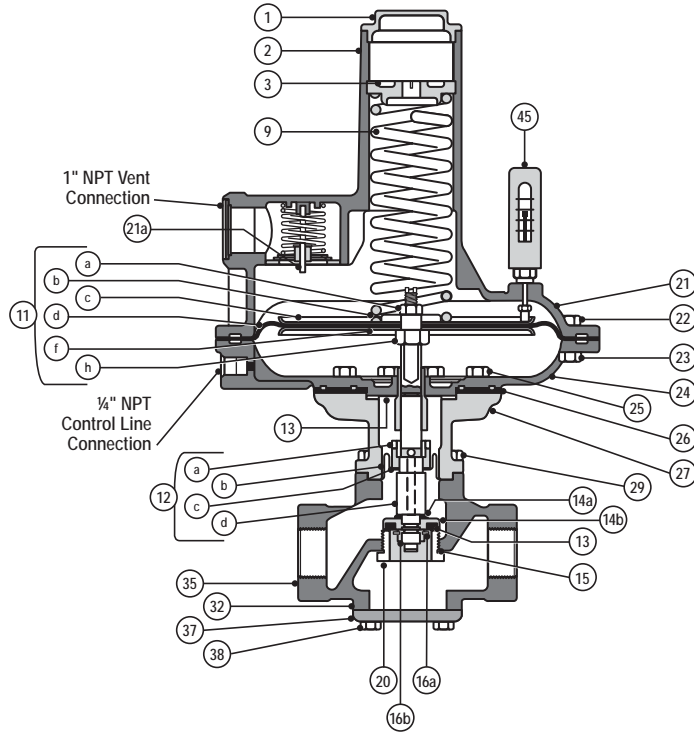

GIM1328-025

121-8 – BACK PRESSURE

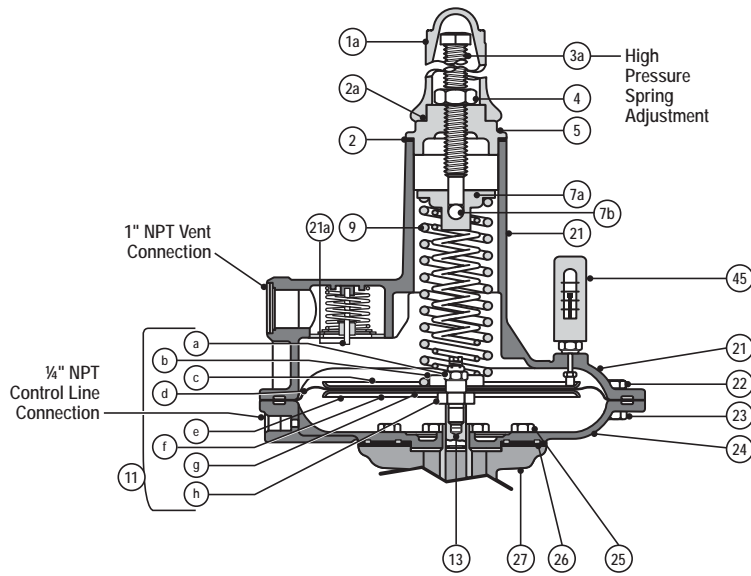

GIM1328-030

121-8 – HIGH PRESSURE – BACK PRESSURE

Condensed Parts List 3/4", 1" and 1 1/4"

Illustration Number	Description	Part Number
1	Seal Cap	143-16-005-00
1a	Seal Cap	121-10-005-52
2	Tetraseal (or O-ring) 2 1/4" x 2 3/8"	905241
2a	Tetraseal (or O-ring) 1 1/2" x 1 5/8"	906534
3	Adjustment Spring Button	143-16-009-00
3a	Spring Adjusting Screw	906537
4	Jam Nut 1/2"-13	921005
5	Housing Cover	121-10-005-51
7a	Top Spring Button	121-10-009-51
7b	Thrust Bearing, stainless ball, 3/8" diameter	930510
9	Spring, see table "Spring Ranges"	
11	121-8 Standard Diaphragm Assembly (3 1/2" w.c. to 4 1/4" psi outlet pressure)	121-10-550-52
	11a Elastic Stop Nut 52-NTE-066	908561
	11b Bottom Spring Button	121-10-220-50
	11c Diaphragm Pan	121-10-017-50
	11d Diaphragm, Buna-N	121-10-150-50
	11d Diaphragm, Viton	121-10-150-52
	11f Seal Washer	121-10-178-50
	11h Diaphragm Stud, stainless steel	091-16-058-02
11	121-8 HP High Pressure Diaphragm Assembly (3 psi to 10 psi outlet pressure)	121-10-550-55
	11a Elastic Stop Nut 29-NE-066	903955
	11b Bottom Spring Button	121-10-022-53
	11c Diaphragm Pan	121-10-017-50
	11d Diaphragm, Buna-N	121-10-150-50
	11d Diaphragm, Viton	121-10-150-52
	11e Upper Plate	121-10-022-52
	11f Seal Washer	121-10-178-50
11g Lower Plate	121-10-079-52	
11h Diaphragm Stud, stainless steel	091-16-058-02	
12	121 Seal Diaphragm Assembly Buna-N	121-10-564-51
	121 Seal Diaphragm Assembly Viton	121-10-564-52
	12a Piston	121-10-053-51
	12b Seal Diaphragm, Buna-N	121-10-364-50
	12b Seal Diaphragm, Viton	121-10-364-51
12	12c Plate	121-10-010-50
	12d Stem, stainless steel	121-10-016-53
13	O-ring, Buna-N, 3/8" x 1/2"	934007
	O-ring, Viton, 3/8" x 1/2"	902418
14	Wave Washer	905479
15	Molded Valve, Buna-N (45-50 Duro)	121-10-311-50
	Molded Valve, Viton-A (65-75 Duro)	121-10-311-51

Condensed Parts List 3/4", 1" and 1 1/4" (Continued)

Illustration Number	Description	Part Number
16a	Retaining Ring	904447
16b	Valve Holder, split (pair required), stainless steel	121-16-130-51
19	Orifice, 1/4" dia., brass	143-16-023-03
	Orifice, 1/4" dia., stainless steel	143-16-023-14
26	Gasket	121-16-063-51
32	Tetraseal (or O-ring) 2 3/8" x 2 1/2"	904081
46	Repair Kits, consisting of Buna-N Main and Seal Diaphragms, Buna-N Molded Valve plus Wave Washer and Retaining Ring, Buna-N O-rings, Tetraseals and Gaskets: For 121-8 For 121-8 HP	121-10-598-50
		121-10-598-51
For Back Pressure Models		
12	Item 12d above, Stem, stainless steel – substitute Stem, Back Pressure	121-10-016-55
14	Item 14 above, Wave Washer – substitute Poly-U Disk Retainer	121-16-102-52
		121-16-103-51 121-10-023-50
19	Item 19 above, Orifice – substitute Orifice, Back Pressure (Brass) Orifice, Back Pressure (stainless steel)	121-10-023-51
46	Item 46 above, Repair Kits – substitute For 121-8 Back Pressure For 121-8 HP Back Pressure	121-10-598-54 Contact Sensus
47	Add Item 47 Valve, Seal Diaphragm and Stem Assembly	121-10-511-54

Servicing – ¾", 1", 1¼" General Instructions

1. Make sure the regulator is entirely depressured before servicing.
2. Carefully note location and position of all disassembled parts to be certain reassembly is correct. Inspect each one carefully and replace those that are worn or damaged or otherwise unsatisfactory.
3. A moderate application of lubricant to O-ring **13** will ensure free stem movement and a tight seal. Similar application of lubricant to other O-rings or Tetraseals will ensure their tightness. Do not use petroleum based lubricants.
4. Bolted connections should be tightened evenly and firmly. Carefully tighten diaphragms into place. Bolts must be tight enough to prevent leakage, but not so tight that the diaphragm material is crushed or damaged.
5. Upon completion of servicing, make certain that regulator installation is entirely free of leaks.

To Service Valve – 15

1. Remove bolts **38** and remove bottom cap **37** and Tetraseal **32**.
2. Remove Retaining Ring **16a**.
3. Remove both halves of valve holder **16b**.
4. Remove valve **15** (wave washer **14** will likely remove with the valve). Retain it for reassembly
– To reassemble, replace parts in reverse sequence.

To Service Main Diaphragm – 11d

1. Remove top cap **1**, and release and remove adjustment **3** or **3a**. On high pressure model remove cap **1a**, release adjustment **3a**, and remove cover **5** and button **7a**. Mark or measure position of adjustment **3** or **3a**. Use this to return adjustment to this setting during assembly.
2. Remove spring **9**.
3. Remove bolts **22** and upper case **21**.
4. Rotate diaphragm assembly **11** counterclockwise (this unscrews **11h** from **12d**) and remove.
5. To disassemble diaphragm assembly, remove nut **11a**. Carefully note location and position of all parts to be certain of correct reassembly. Abrasive side of emery cloth washers face against diaphragm.
– To reassemble, replace parts in reverse sequence. **Make sure the screwed connection between 11h and 12d is loosened approximately one-half turn.** To do this, carefully rotate diaphragm assembly **11** clockwise until this screwed connection bottoms (do not jam it together). Then, back-off diaphragm assembly **11** counter-clockwise approximately one-half turn. The **11h** and **12d** screwed connection must not be tight.

To Service Orifice – 19

1. Remove valve **15** per section "To Service Valve – 15".
2. Unscrew orifice **19** using 1½" hex socket wrench. When replacing orifice use a moderate amount of pipe dope on orifice threads.

To Service Seal Diaphragm – 12b

1. Remove valve **15** per section "To Service Valve – 15".
2. Remove diaphragm assembly **11** per section "To Service Main Diaphragm – 11d".
3. Remove bolts **25** and lower diaphragm case **24**.
4. Remove bolts **29** and center piece **27**, and then remove seal diaphragm assembly **12**.
5. To disassemble **12**, unscrew piston **12a** from stem **12d**. Use a spanner wrench in notch in skirt of piston (this can also be done by inserting a standard 7/32" Allen wrench in the notch).
– To reassemble, replace parts in reverse sequence. Make certain fabric side of seal diaphragm **12b** faces upward and "rubber" side faces downward toward body. Do not pinch loop in seal diaphragm **12b** between **35** and centerpiece **27**.

Periodic Inspection:

Regulators are pressure control devices with numerous moving parts subject to wear that is dependent upon particular operation conditions. To assure continuous satisfactory operation, adhere to a periodic inspection schedule with the frequency of inspections determined by the severity of service and applicable laws and regulations.

Servicing – ¾", 1", 1¼"

Back Pressure Models General Instructions

1. Make sure the regulator is entirely depressured before servicing.
2. Carefully note location and position of all disassembled parts to be certain reassembly is correct. Inspect each one carefully and replace those that are worn or damaged or otherwise unsatisfactory.
3. A moderate application of lubricant to O-ring **13** will ensure free stem movement and a tight seal. Similar application of lubricant to the other O-rings or Tetraseals will ensure their tightness. Do not use petroleum base lubricants.
4. Bolted connections should be tightened evenly and firmly. Carefully tighten diaphragms into place. Bolts must be tight enough to prevent leakage, but not so tight that the diaphragm material is crushed or damaged.
5. Upon completion of servicing, make certain that regulator installation is entirely free of leaks.

To Service Valve – 15

1. Remove bolts **29** and remove upper case assembly.
2. Remove Retaining Ring **16a**.
3. Remove both halves of valve holder **16b**.
4. Remove valve **15** (washer **14a** and holder **14b** will likely remove with the valve). Retain for reassembly.
– To reassemble, replace parts in reverse sequence.

To Service Main Diaphragm – 11d

1. Remove top cap **1**, and release and remove adjustment **3**. On high pressure model remove cap **1a**, release adjustment **3a**, and remove cover **5** and button **7a**. Mark or measure position of adjustment **3** or **3a**. Use this to return adjustment to this setting during reassembly.
2. Remove spring **9**.
3. Remove bolts **22**, nuts **23**, and upper case **21**.
4. Rotate diaphragm assembly **11** counterclockwise (this unscrews **11h** from **12**) and remove.
5. To disassemble diaphragm assembly, remove nut **11a**. Carefully note location and position of all parts to be certain of correct reassembly. Abrasive side of emery cloth washers face against diaphragm.
– To reassemble, replace parts in reverse sequence.
Make sure the screwed connection between 11h and 12d is loosened approximately one-half turn. To do this, carefully rotate diaphragm assembly **11** clockwise until this screwed connection bottoms (do not jam it together). Then, back-off diaphragm assembly **11** counterclockwise approximately one-half turn. The **11h** to **12d** screwed connection must not be tight.

To Service Orifice – 20

1. Remove top cap **1**, and release and remove adjustment **3**. On high pressure model remove cap **1a**, release adjustment **3a**, and remove cover **5** and button **7a**. Mark or measure position of adjustment **3** or **3a**. Use this to return adjustment to this setting during reassembly.
2. Remove spring **9**.
3. Remove bolts **38** and bottom cap **37** along with Tetraseal **32**.
4. Unscrew orifice **20** using 1⅝" hex socket wrench. When replacing orifice use a moderate amount of pipe dope on orifice threads.
– To reassemble, replace parts in reverse sequence.

To Service Seal Diaphragm – 12b

1. Remove bolts **29**, upper case assembly, and then remove seal diaphragm, and stem assembly **12**.
2. To disassemble **12**, screw piston **12a** from stem **12d**. Use a spanner wrench in notch in skirt of piston (this can also be done by inserting a standard 7/32" Allen wrench in the notch).
– To reassemble, replace parts in reverse sequence. Make certain that fabric side of seal diaphragm **12b** faces upward and "rubber" side faces downward toward body. Do not pinch loop in seal diaphragm **12b** between **35** and centerpiece **27**.

Periodic Inspection:

Regulators are pressure control devices with numerous moving parts subject to wear that is dependent upon particular operation conditions. To assure continuous satisfactory operation, adhere to a periodic inspection schedule with the frequency of inspections determined by the severity of service and applicable laws and regulations.

1½" – 2" – 2½"
Standard, Differential, Atmospheric or Zero Governors

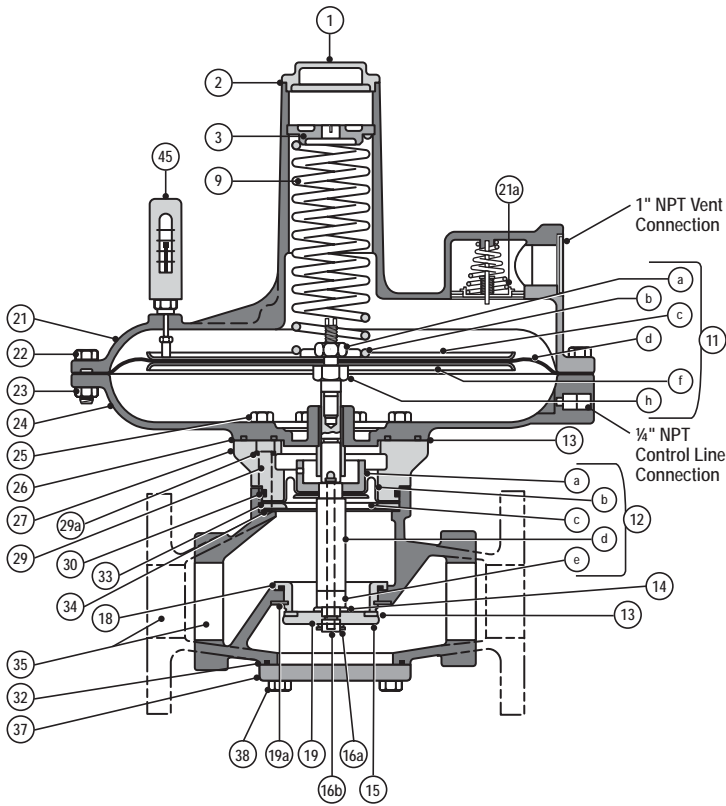

121-12 – STANDARD

GIM1328-035

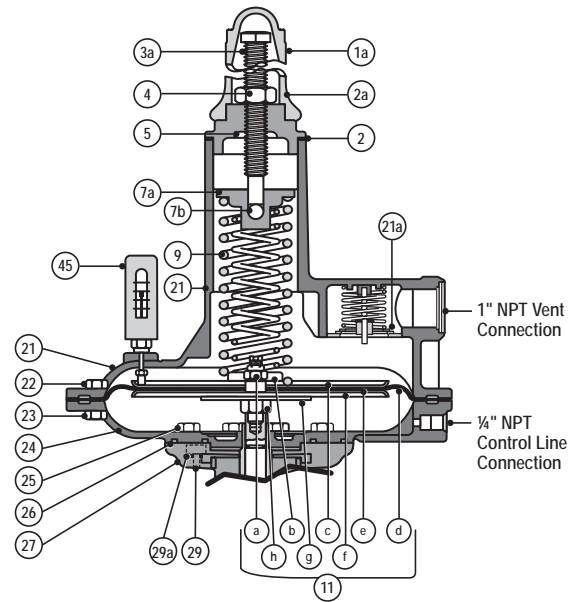

121-8 HP – HIGH PRESSURE

GIM1328-045

Pipe Sizes
(Inlet x Outlet) Screwed, NPT

1½" x 1½"

1½" x 2"

2" x 2"

2½" x 2½"

Flanged ANSI 125 lb. FF

2" x 2"

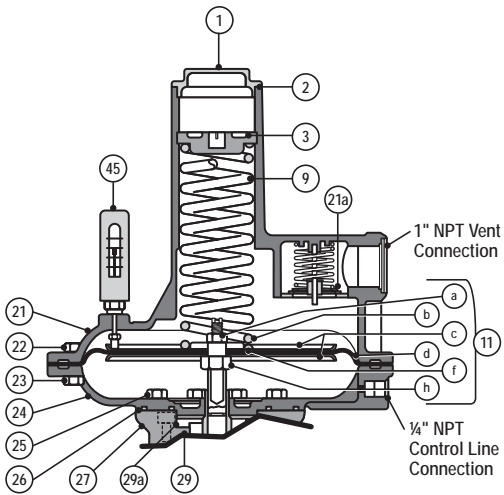

121-8 – STANDARD

GIM1328-040

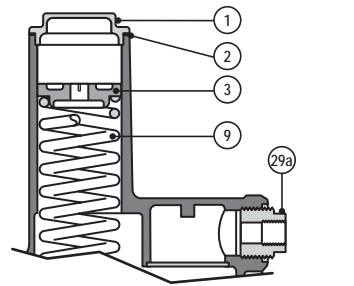

GIM1328-050

Fig. 1
Adjustment 3 and Vent Connection
12b for Differential Regulators,
Atmospheric Regulators and
Zero Governors

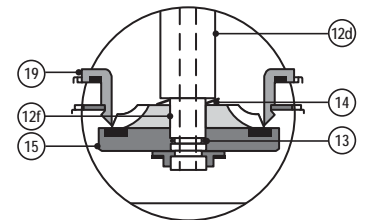

GIM1328-055

V-PORT WING OPTION

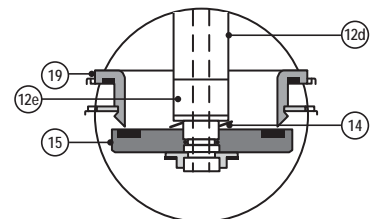

GIM1328-060

STANDARD RETAINER OPTION

1½" – 2" – 2½"
Standard, Differential, Atmospheric or Zero Governors

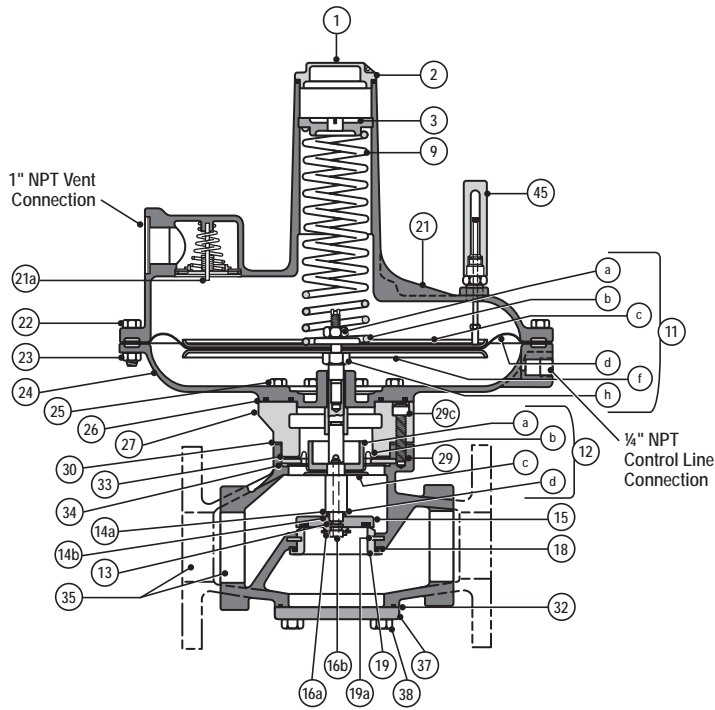

121-12 – BACK PRESSURE

GIM1328-065

Pipe Sizes (Inlet x Outlet) Screwed, NPT
1½" x 1½"
1½" x 2"
2" x 2"
2½" x 2½"
Flanged ANSI 125 lb. FF
2" x 2"

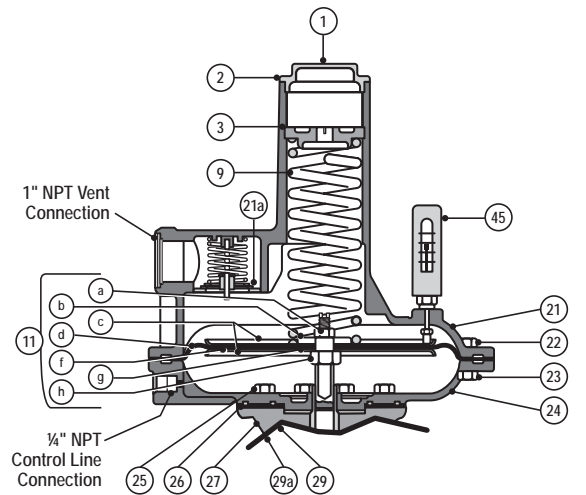

121-8 – BACK PRESSURE

GIM1328-070

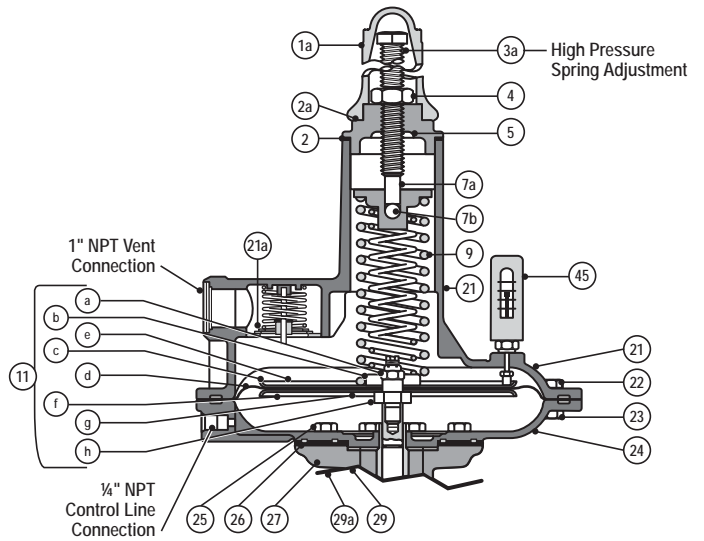

121-8 HP – HIGH PRESSURE – BACK PRESSURE

GIM1328-075

Condensed Parts List 1½", 2" and 2½"

Illustration Number	Description	Part Number
1	Seal Cap	143-16-005-00
1a	Seal Cap	121-10-005-52
2	Tetraseal (or O-ring) 2¼" x 2⅝"	905241
2a	Tetraseal (or O-ring) 1½" x 1⅝"	906534
3	Adjustment Spring Button	143-16-009-00
3a	Spring Adjusting Screw	906537
4	Hex Steel Nut	921005
5	Housing Cover	121-10-005-51
7a	Top Spring Button	121-10-009-51
7b	Thrust Bearing, stainless ball, ⅜" diameter	930510
9	Spring, see table "Spring Ranges"	
11	121-12 Diaphragm Assembly (3½" w.c. to 2 psi outlet pressure)	121-16-550-51
	11a Elastic Stop Nut 52-NTE-066	908561
	11b Bottom Spring Button	121-10-022-50
	11c Diaphragm Pan	121-16-017-50
	11d Molded Diaphragm, Buna-N	121-16-150-53
	11d Diaphragm, Viton	121-16-150-55
	11f Seal Washer	121-10-178-50
	11h Diaphragm Stud, stainless steel	121-16-058-52
11	121-8 Standard Diaphragm Assembly (1 psi to 4¼ psi outlet pressure)	121-10-551-52
	11a Elastic Stop Nut 29-NE-066	903955
	11b Bottom Spring Button	121-10-022-50
	11c Diaphragm Pan	121-10-017-50
	11d Diaphragm, Buna-N	121-10-150-50
	11d Diaphragm, Viton	121-10-150-52
	11f Seal Washer	121-10-178-50
	11h Diaphragm Stud, stainless steel	091-16-058-0
11	121-8 HP High Pressure Diaphragm Assembly (3 psi to 10 psi outlet pressure)	121-10-550-55
	11a Elastic Stop Nut 29-NE-066	903955
	11b Diaphragm Plate	121-10-022-53
	11c Diaphragm Pan	121-10-017-50
	11d Diaphragm, Buna-N	121-10-150-50
	11d Diaphragm, Viton	121-10-150-52
	11e Upper Plate	121-10-022-52
	11f Seal Washer	121-10-178-50
	11g Lower Plate	121-10-079-52
	11h Diaphragm Stud, stainless steel	091-16-058-02
12	121 Seal Diaphragm Assembly, Buna-N	121-16-564-51
	121 Seal Diaphragm Assembly, Viton	121-16-564-52
	12a Piston	121-16-053-51
	12b Seal Diaphragm, Buna-N	121-16-364-50
	12 12b Seal Diaphragm, Viton	121-16-364-51
	12c Plate	121-16-010-53
	12d Stem, stainless steel	121-16-016-53
	12e Retainer	121-16-016-00
12f V-Port Wings	121-16-012-52	
13	O-ring, Buna-N ⅜" x ½"	934007
	O-ring, Viton ⅜" x ½"	902418
14	Wave Washer	905479

Condensed Parts List 1½", 2" and 2½" (Continued)

Illustration Number	Description	Part Number	
15	Molded Valve, Buna-N (45-50 Duro)	121-16-311-50	
	Molded Valve, Viton-A (65-75 Duro)	121-16-311-51	
16a	Retaining Ring	904447	
16b	Valve Holder, split (pair required), stainless steel	121-16-130-51	
18	Tetraseal (or O-Ring) 2½" x 2⅞"	904207	
19	Orifice, 2⅝" dia., stainless steel	121-16-023-51	
	Orifice, 2⅝" dia., stainless steel	121-16-023-52	
19a	Retaining Ring, stainless	904656	
26	Gasket	121-16-063-51	
29a	Copper Washer	121-16-178-51	
30	O-Ring, 3⅜" x 3½"	934041	
32	Tetraseal (or O-ring) 3¼" x 3½"	904078	
33	Seal Diaphragm Ring	121-16-008-50	
34	Gasket	121-16-104-50	
45	Travel Indicator	Contact Sensus	
46	Repair Kits, consisting of Buna-N Main and Seal Diaphragms, Buna-N Molded Valve plus Wave Washer and Retaining Ring, Buna-N O-rings, Tetraseals and Gaskets:	For 121-12	121-16-598-50
		For 121-8	121-86-598-50
		For 121-8 HP	121-86-598-51
For Back Pressure Models			
12	Item 12d above, Stem, stainless steel – substitute Stem, Back Pressure	121-16-016-55	
14	Item 14 above, Wave Washer – substitute Poly-U Disk Retainer	121-16-102-52	
		121-16-103-51	
46	Item 46 above, Repair Kits – substitute	For 121-12 Back Pressure	121-16-598-52
		For 121-8 Back Pressure	121-86-598-54
		For 121-8 HP Back Pressure	121-86-598-55
47	Add Item 47 Valve, Seal Diaphragm and Stem Assembly	121-16-511-51	

Servicing – 1½", 2", 2½"

General Instructions

1. Make sure the regulator is entirely depressured before servicing.
2. Carefully note location and position of all disassembled parts to be certain reassembly is correct. Inspect each one carefully and replace those that are worn or damaged or otherwise unsatisfactory.
3. A moderate application of lubricant to O-ring **13** will ensure free stem movement and a tight seal. Similar application of lubricant to other O-rings or Tetraseals will ensure their tightness. Do not use petroleum base lubricants.
4. Bolted connections should be tightened evenly and firmly. Carefully tighten diaphragms into place. Bolts must be tight enough to prevent leakage, but not so tight that the diaphragm material is crushed or damaged.
5. Upon completion of servicing, make certain that regulator installation is entirely free of leaks.

To Service Valve – 15

1. Remove bolts **38** and remove bottom cap **37** and Tetraseal **32**.
2. Remove Retaining Ring **16a**.
3. Remove both halves of valve holder **16b**.
4. Remove valve **15** (wave washer **14** will likely remove with the valve). Retain for reassembly.
– To reassemble, replace parts in reverse sequence.

To Install V-Port Wing – 12f

1. Remove valve **15** per section "To Service Valve – 15".
2. Remove wave washer **14**.
3. Remove retainer **12e**. It will not be used.
4. Reinstall wave washer **14**.
5. Install V-Port wing **12f** on stem with v-notch side against the wave washer and flat area exposed.
6. Reassemble remaining parts in reverse sequence.

To Service Main Diaphragm – 11d

1. Remove top cap **1**, and release and remove adjustment **3**. On high pressure model remove cap **1a**, release adjustment **3a**, and remove cover **5** and button **7a**. Mark or measure position of adjustment **3** or **3a**. Use this to return adjustment to this setting during reassembly.
2. Remove spring **9**.
3. Remove bolts **22** and upper case **21**.
4. Rotate diaphragm assembly **11** counterclockwise (this unscrews **11h** from **12d**) and remove.
5. To disassemble diaphragm assembly, remove nut **11a**. Carefully note location and position of all parts to be certain of correct reassembly. Abrasive side of emery cloth washers face against diaphragm.
– To reassemble, replace parts in reverse sequence. **Make sure the screwed connection between 11h and 12d is loosened approximately one-half turn.** To do this, carefully rotate diaphragm assembly **11** clockwise until this screwed connection bottoms (do not jam it together). Then back-off diaphragm assembly **11** counterclockwise approximately one-half turn. The **11h** to **12d** screwed connection must not be tight.

To Service Orifice – 19

1. Remove valve **15** per section "To Service Valve – 15".
2. Remove main diaphragm assembly **11** per steps 1 through 4 under "To Service Main Diaphragm – 11d".
3. Remove seal diaphragm assembly **12** per steps 3 and 4 under "To Service Seal Diaphragm – 12b".
4. Remove Retaining Ring **19a**.
5. Remove orifice **19** through top opening.
– To reassemble, replace parts in reverse sequence. (On reassembly, ensure that **19a** is fully seated in its groove. Also, beveled edge of **19a** faces downward toward bottom cap **37**.)

To Service Seal Diaphragm – 12b

1. Remove valve **15** per section "To Service Valve – 15".
2. Remove main diaphragm assembly **11** per steps 1 through 4 under "To Service Main Diaphragm – 11d".
3. Remove bolts **25** and lower diaphragm case **24**.
4. Remove bolts **29** and centerpiece **27**, and then remove seal diaphragm assembly **12**.
5. To disassemble **12**, unscrew piston **12a** from stem **12d**. Use a spanner wrench in notch in skirt of piston (this can also be done by inserting a standard 7/32" Allen wrench in the notch).
– To reassemble, replace parts in reverse sequence. Make certain that fabric side of seal diaphragm **12b** faces upward and "rubber" side faces downward toward body. Do not pinch loop in seal diaphragm **12b** between ring **33** and centerpiece **27**. Also, rounded edge of **33** faces upward toward seal diaphragm **12b**.

Periodic Inspection:

Regulators are pressure control devices with numerous moving parts subject to wear that is dependent upon particular operation conditions. To assure continuous satisfactory operation, adhere to a periodic inspection schedule with the frequency of inspections determined by the severity of service and applicable laws and regulations.

Servicing – 1½", 2", 2½" Back Pressure Models General Instructions

1. Make sure the regulator is entirely depressured before servicing.
2. Carefully note location and position of all disassembled parts to be certain reassembly is correct. Inspect each one carefully and replace those that are worn or damaged or otherwise unsatisfactory.
3. A moderate application of lubricant to O-ring **13** will ensure free stem movement and a tight seal. Similar application of lubricant to other O-rings or Tetraseals will ensure their tightness. Do not use petroleum base lubricants.
4. Bolted connections should be tightened evenly and firmly. Carefully tighten diaphragms into place. Bolts must be tight enough to prevent leakage, but not so tight that the diaphragm material is crushed or damaged.
5. Upon completion of servicing, make certain that regulator installation is entirely free of leaks.

To Service Main Diaphragm – 11d

1. Remove top cap **1**, and release and remove adjustment **3**. On high pressure model remove cap **1a**, release adjustment **3a**, and remove cover **5** and button **7a**. Mark or measure position of adjustment **3** or **3a**. Use this to return adjustment to this setting during reassembly.
2. Remove spring **9**.
3. Remove bolts **22**, nuts **23** and upper case **21**.
4. Rotate diaphragm assembly **11** counterclockwise (this unscrews **11h** from **12**) and remove.
5. To disassemble diaphragm assembly, remove nut **11a**. Carefully note location and position of all parts to be certain of correct reassembly. Abrasive side of emery cloth washers face against diaphragm.
 - To reassemble, replace parts in reverse sequence. **Make sure the screwed connection between 11h and 12d is loosened approximately one-half turn.** To do this, carefully rotate diaphragm assembly **11** clockwise until this screwed connection bottoms (do not jam it together). Then, back-off diaphragm assembly **11** counterclockwise approximately one-half turn. The **11h** to **12d** screwed connection must not be tight.

To Service Seal Diaphragm – 12b

1. Remove main diaphragm assembly **11** per steps 1 through 4 under "To Service Main Diaphragm – 11d".
2. Remove bolts **29** and centerpiece **27**, then remove seal diaphragm, valve and stem assembly **12**.
3. To disassemble **12**, unscrew piston **12a** from stem **12d**. Use a spanner wrench in notch in skirt of piston (this can also be done by inserting a standard ⅜" Allen wrench in the notch).
 - To reassemble, replace parts in reverse sequence. Make certain that fabric side of seal diaphragm **12b** faces upward and "rubber" side faces downward toward body. Do not pinch loop on seal diaphragm **12b** between ring **33** and centerpiece **27**. Also rounded edge of **33** faces upward toward seal diaphragm **12b**.

To Service Valve – 15

1. Remove main diaphragm assembly **11** per steps 1 through 4 under "To Service Main Diaphragm – 11d".
2. Remove seal diaphragm, valve and stem assembly to service seal diaphragm **12b**.
3. Remove Retaining Ring **16a**.
4. Remove both halves of valve holder **16b**.
5. Remove valve **15** (washer **14** and holder **14a** will likely remove with the valve). Retain for reassembly.
 - To reassemble, replace parts in reverse sequence.

To Service Orifice – 19

1. Remove main diaphragm assembly **11** per steps 1 through 4 under "To Service Seal Diaphragm – 11d".
2. Remove seal diaphragm, valve and stem assembly **12** per steps 2 and 3 under "To Service Seal Diaphragm – 12b".
3. Remove Retaining Ring **19a** through top opening.
4. Remove orifice **19** through bottom opening.
 - To reassemble, replace parts in reverse sequence. (On reassembly, be sure that **19a** is fully seated in its groove. Also, beveled edge of **19a** faces upward toward adapter **27**.)

Periodic Inspection:

Regulators are pressure control devices with numerous moving parts subject to wear that is dependent upon particular operation conditions. To assure continuous satisfactory operation, adhere to a periodic inspection schedule with the frequency of inspections determined by the severity of service and applicable laws and regulations.

3" – 4" Standard

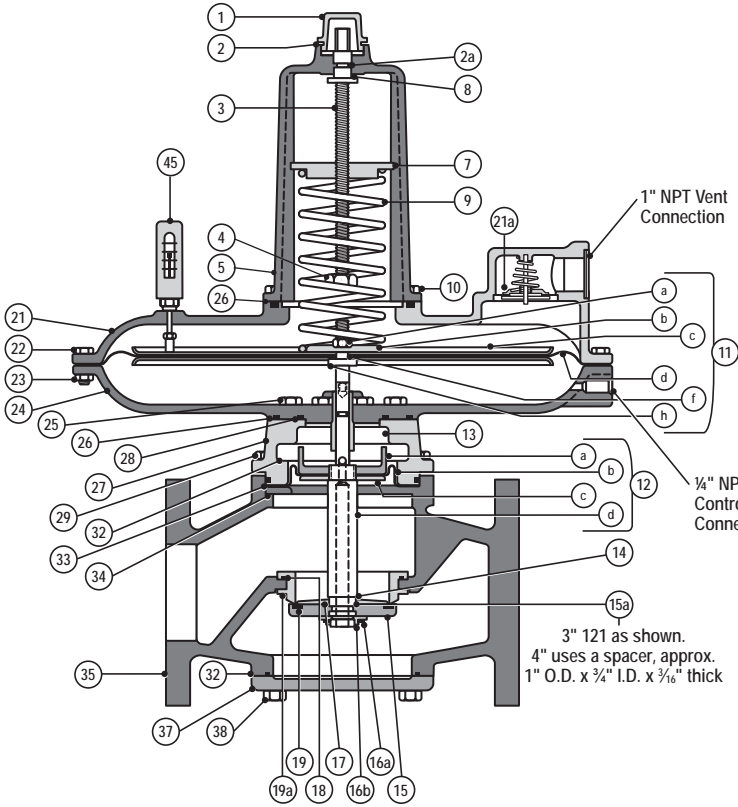

GIM1328-080

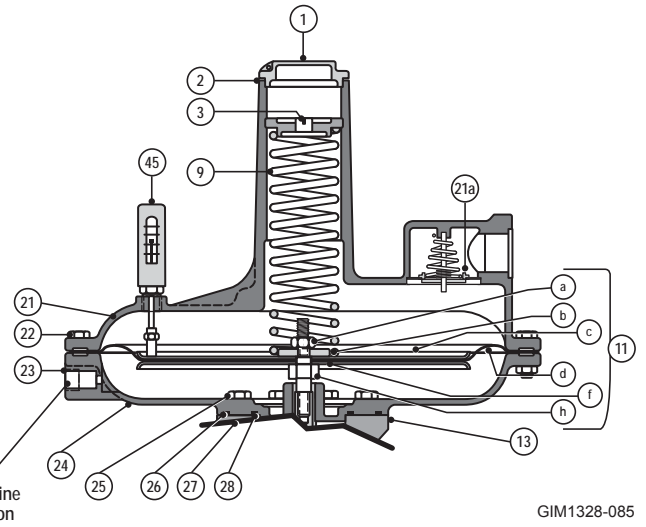

GIM1328-085

Pipe Sizes (Inlet x Outlet) Flanged ANSI 125 lb. FF	
3" x 3"	
4" x 4"	

3" – 4" Back Pressure

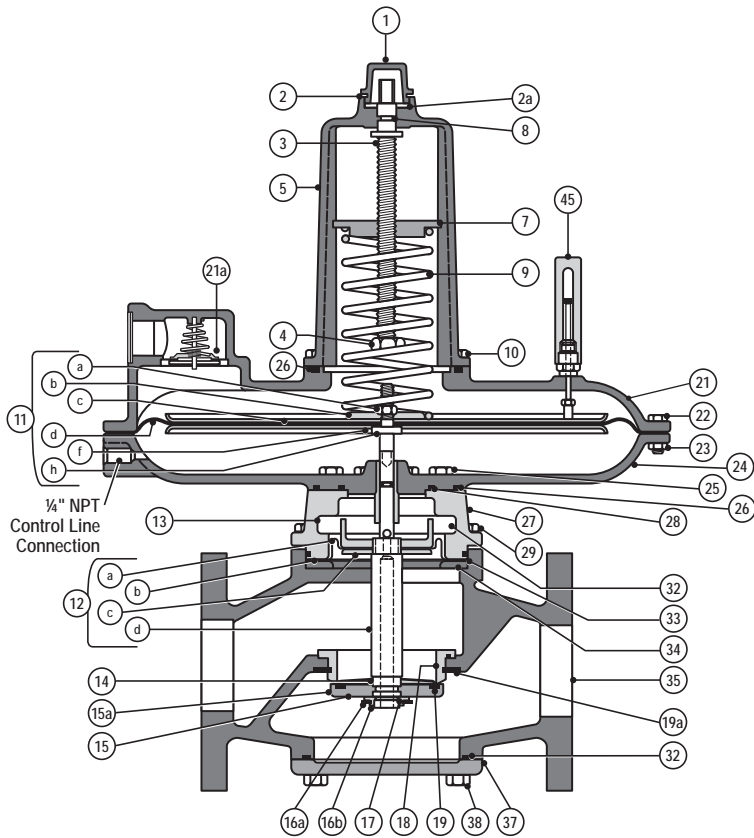

GIM1328-090

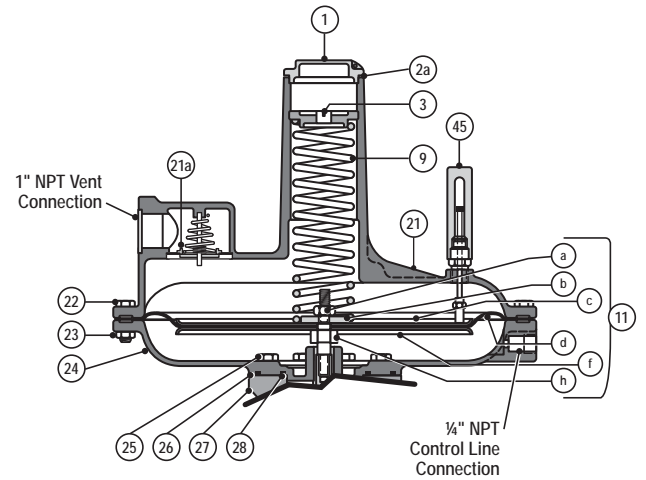

GIM1328-095

Condensed Parts List 3" and 4"

Illustration Number	Description	Part Number
3" and 4" Model 121		
1	Seal Cap for 121-16 Seal Cap for 121-12	138-02-005-01 143-16-005-00
2	Seal Cap Gasket for 121-16 Tetraseal for 121-12, 2 1/4" x 2 3/8"	120-08-066-00 905241
3	Adjustment Spring Button for 121-12	143-16-009-00
8	Thrust Washer	141-10-160-01
9	Spring see table "Spring Ranges"	
11	121-16 Diaphragm Assembly	121-62-550-50
	11a Elastic Stop Nut 52-NTE-066	903955
	11b Bottom Spring Button	121-62-022-50
	11c Diaphragm Pan	121-62-017-50
	11d Diaphragm, Buna-N	121-62-150-50
	11d Diaphragm, Viton	121-62-150-52
	11f Seal Washer	121-10-178-50
	11h Diaphragm Stud, stainless steel	121-16-058-52
11	121-12 Diaphragm Assembly (3 1/2" w.c. to 2 psi outlet pressure)	121-16-550-51
	11a Elastic Stop nut 29-NE-066	903955
	11b Bottom Spring Button	121-10-022-50
	11c Diaphragm Pan	121-16-017-50
	11d Molded Diaphragm, Buna-N	121-16-150-53
	11d Diaphragm, Viton	121-16-150-55
	11f Seal Washer	121-10 178-50
	11h Diaphragm Stud, stainless steel	121-16-058-52
13	O-ring, Buna-N, 3/8" x 1/2"	934007
	O-ring, Viton, 3/8" x 1/2"	902418
14	Wave Washer	905481
16a	Retaining Ring	904448
16b	Valve Holder, split (pair required), stainless steel	121-22-130-51
17	O-ring, Buna-N, 5/8" x 3/4"	902922
	O-ring, Viton, 5/8" x 3/4"	902698
26	Tetraseal (or O-ring) 4 3/8" x 4 5/8"	904085
28	Tetraseal (or O-ring) 2 3/4" x 3"	904079
46	Repair Kits, consisting of Buna-N Main and Seal Diaphragm, Buna-N Molded Valve plus Wave Washer and Retaining Ring, Buna-N O-rings, Tetraseals and Gaskets	
	3" 121-16	121-60-598-50
	3" 121-12	121-20-598-50
	4" 121-16	121-62-598-50
	4" 121-12	121-22-598-50
For Back Pressure Models		
14	Item 14 above, Wave Washer – substitute Poly-U Disk Retainer	121-22-102-52 121-22-103-50

Condensed Parts List 3" and 4" (Continued)

Illustration Number	Description	Part Number
3" Model 121		
12	12a Piston	121-20-053-50
	12b Seal Diaphragm, Buna-N	121-20-364-50
	12b Seal Diaphragm, Viton	121-20-364-51
	12c Plate	121-20-010-50
	12d Stem, stainless steel	121-20-016-51
15	Molded Valve, Buna-N (45-50 Duro)	121-20-311-50
	Molded Valve, Viton-A (65-75 Duro)	121-20-311-51
15a	Valve Wing	121-20-018-50
	Valve Wing, stainless steel	121-20-018-51
18	Tetraseal (or O-ring) 3 3/4" x 4"	904200
19	Orifice, 3/4" dia., steel	121-20-023-50
	Orifice, 3/4" dia., stainless steel	121-20-023-51
19a	Retaining Ring, stainless	904660
32	Tetraseal (or O-ring) 5" x 5 1/4"	934328
33	Seal Diaphragm Ring	121-20-008-50
34	Gasket	121-20-104-50
45	Travel Indicator (specify scale 091-00-008-02)	091-00-365-00
For Back Pressure Models		
12	Item 12d above, Stem – substitute Stem, Back Pressure	121-20-016-53
47	Add item 47 Valve, Seal Diaphragm and Stem Assembly	121-20-511-50
4" Model 121 only		
12	12a Piston	121-22-053-50
	12b Seal Diaphragm, Buna-N	121-22-264-50
	12b Seal Diaphragm, Viton	121-22-364-51
	12c Plate	121-22-010-50
	12d Stem, steel	121-22-016-53
	12d Stem, stainless steel	121-22-016-51
15	Molded Valve, Buna-N (45-50 Duro)	121-22-311-50
	Molded Valve, Viton-A (65-75 Duro)	121-22-311-51
15a	Valve Spacer	121-22-038-50
18	Tetraseal (or O-ring) 4 3/4" x 5"	950625
19	Orifice, 4 7/32" dia., steel	121-22-023-50
19a	Retaining Ring	904229
20	Orifice, 4 7/32" dia., stainless steel	121-22-023-52
20a	Retaining Ring, stainless Pliers for Retaining Ring 19a Truarc 0600	121-22-130-52 OB5
32	O-ring 6 1/4" x 6 1/2"	934337
33	Seal Diaphragm Ring	121-22-008-50
34	Gasket	121-22-104-50
45	Travel indicator (specify scale 091-00-008-002)	091-00-365-00
For Back Pressure Models		
12	Item 12d above, Stem - substitute Stem, Back Pressure	121-20-016-53
47	Add item 47 Valve, Seal Diaphragm and Stem Assembly	121-20-511-50

Servicing – 3", 4" General Instructions

Same general instructions as listed on Page 8.

To Service Valve – 15

1. Remove bolts **38** and remove bottom cap **37**.
2. Remove Retaining Ring **16a**.
3. Remove both halves of valve holder **16b**.
4. Remove valve **15**, and wing **15a** or spacer (wave washer **14** will likely remove with the valve). Retain it for reassembly.
– To reassemble, replace parts in reverse sequence.

To Service Main Diaphragm – 11d

1. Remove top cap **1**.
2. Release adjustment **3** (count the turn of adjustment **3** and use for returning the adjustment to this setting during assembly).
3. Remove bolts **10** and housing **5** (3" and 4" 121-16 only).
4. Remove spring **9**.
5. Remove bolts **22** and upper case **21**.
6. Rotate diaphragm assembly **11** counterclockwise (this unscrews **11h** from **12d**) and remove.
7. To disassemble diaphragm assembly, remove nut **11a**. Carefully note location and position of all parts to be certain of correct reassembly. Abrasive side of emery cloth washers face against diaphragm.
– To reassemble, replace parts in reverse sequence.

Make sure the screwed connection between 11h and 12d is loosened approximately one-half turn. To do this, carefully rotate diaphragm assembly **11** clockwise until this screwed connection bottoms (do not jam it together). Then back-off diaphragm assembly **11** counterclockwise approximately one-half turn. The **11h** to **12d** screwed connection must not be tight.

To Service Orifice – 19

1. Remove valve **15** per section "To Service Valve – 15".
2. Remove seal diaphragm assembly **12** per step 2 under "To Service Seal Diaphragm – 12b".
3. Remove Retaining Ring **19a**.
4. Remove ring **33** and orifice **19** through top opening.
– To reassemble, replace parts in reverse sequence. (On reassembly, be sure that **19a** is fully seated in its groove. Also, beveled edge of **19a** faces downward toward bottom cap **37**.)

To Service Seal Diaphragm – 12b

1. Remove valve **15** per section "To Service Valve – 15".
2. Remove bolts **29** and upper case assembly. Then remove seal diaphragm assembly **12**.
3. To disassemble **12**, unscrew piston **12a** from stem **12d**. Use a spanner wrench in notch in skirt of piston (this can also be done by inserting a standard $\frac{7}{32}$ " Allen wrench in the notch).
– To reassemble, replace parts in reverse sequence. Make certain that fabric side of seal diaphragm **12b** faces upward and "rubber" side faces downward toward body. Do not pinch loop in seal diaphragm **12b** between ring **33** and centerpiece **27**.

Also, rounded edge of **33** faces upward toward seal diaphragm **12b**. **Make sure the screwed connection 11h and 12d is loosen approximately one-half turn.** To do this, carefully rotate seal diaphragm assembly **12** clockwise until this screwed connection bottoms (do not jam it together). Then, back-off seal diaphragm assembly **12** counter-clockwise approximately one-half turn. The **11h** to **12d** screwed connection must not be tight.

Servicing – 3", 4" Back Pressure Models General Instructions

Same general instructions as listed on Page 8.

To Service Valve – 15

1. Remove bolts **29** and remove upper case and assembly **33**.
2. Remove Retaining Ring **16a**.
3. Remove both halves of valve holder **16b**.
4. Remove valve **15** and wing **15a** or spacer (washer **14** and holder **14b** will likely remove with valve.) Retain for reassembly.
– To reassemble, replace parts in reverse sequence.

To Service Main Diaphragm – 11d

1. Remove top cap **1**.
2. Release adjustment **3** (count the turns of adjustment **3** and use for returning the adjustment to this setting during reassembly).
3. Remove bolts **10** and housing **5** (3" and 4" 121-16 only).
4. Remove spring **9**.
5. Remove bolts **22** and upper case **21**.
6. Rotate diaphragm assembly **11** counterclockwise (this unscrews **11h** from **12d**) and remove.
7. To disassemble diaphragm assembly, remove nut **11a**. Carefully note location and position of all parts to be certain of correct reassembly. Abrasive side of emery cloth washers face against diaphragm.
– To reassemble, replace parts in reverse sequence. **Make sure the screwed connection between 11h and 12d is loosened approximately one-half turn.** To do this, carefully rotate diaphragm assembly **11** clockwise until this screwed connection bottoms (do not jam it together). Then back-off diaphragm assembly **11** counterclockwise approximately one-half turn. The **11h** to **12d** screwed connection must not be tight.

To Service Orifice – 19

1. Remove valve 15 per section “To Service Valve – 15”, item 1.
2. Remove Retaining Ring 19a and ring 33 through top opening.
3. Remove orifice 19 through bottom opening.
 - To reassemble, replace parts in reverse sequence. (On reassembly, be sure that 19a is fully seated in its groove, and beveled edge of 19a faces downward toward bottom cap 37.)

To Service Seal Diaphragm – 12b

1. Remove valve 15 per section “To Service Valve – 15”, item 1.
2. Remove bolts 29 and upper case assembly and then remove seal diaphragm assembly 12.

3. To disassemble 12, unscrew piston 12a from stem 12d. Use a spanner wrench in notch in skirt of piston (this can also be done by inserting a standard 7/32" Allen wrench in the notch).
 - To reassemble, replace parts in reverse sequence. Make certain that fabric side of seal diaphragm 12b faces upward and “rubber” side faces downward toward body.

Do not pinch loop in seal diaphragm 12b between ring 33 and centerpiece 27. Also, rounded edge of 33 faces upward toward seal diaphragm 12b. **Make sure the screwed connection between 11h and 12d is loosened approximately one-half turn.** To do this, carefully rotate seal diaphragm assembly 12 clockwise until this screwed connection bottoms (do not jam it together). Then back-off seal diaphragm assembly 12 counterclockwise approximately one-half turn. The 11h to 12d screwed connection must not be tight.

Variations

Vacuum Breaker

Vacuum Breakers are vacuum limiting devices. In their general function, they can be compared to relief valves or back pressure regulators.

The breaker outlet and control line are piped to the vacuum. The breaker inlet connects to a lesser vacuum, to atmosphere or to a positive pressure. The maximums for the positive pressure are 60 psi for 3/4" through 2 1/2" sizes, 40 psi for 3" and 15 psi for 4". The vacuum breaker is normally closed and excess vacuum creates a valve opening movement which increases flow from the inlet and thereby relieves or “breaks” the excess.

All of the pipe sizes listed on Page 23 are available 3/4" through 4". Note on the cutaway drawing that the main spring is reversed to provide the upward closing force on the valve. Except for certain parts used in the spring assembly, everything else is interchangeable with standard 121 regulators.

Vacuums and Springs

Size	Vacuum Range w.c. vacuum (-w.c.)	Spring Color	Spring Part Number
3/4", 1" and 1 1/4" Model 121-8	3" to 6 1/2"	Red-Black	143-82-021-00
	5" to 8 1/2"	Blue-Black	143-82-021-01
	8" to 14"	Green-Black	143-82-021-02
	12" to 20"	Blue (2" O.D.)	143-16-021-04
	18" to 30"	Green (2" O.D.)	143-16-021-05
	30" to 56"	Orange (2" O.D.)	143-16-021-06
1 1/2", 2" and 2 1/2" Model 121-12	3" to 6 1/2"	Red (2" O.D.)	143-16-021-03
	5" to 8 1/2"	Blue (2" O.D.)	143-16-021-04
	8" to 14"	Green (2" O.D.)	143-16-021-05
	12" to 28"	Orange (2" O.D.)	143-16-021-06
	28" to 56"	Black	143-16-021-07
3" and 4" Model 121-16	3" to 5 1/2"	Red (3" O.D.)	121-62-021-50
	4" to 7 1/2"	Blue (3" O.D.)	121-62-021-51
	7" to 14"	Green (3" O.D.)	121-62-021-52
3" and 4" Model 121-12	12" to 28"	Orange (2" O.D.)	143-16-021-06
	28" to 56"	Black	143-16-021-07

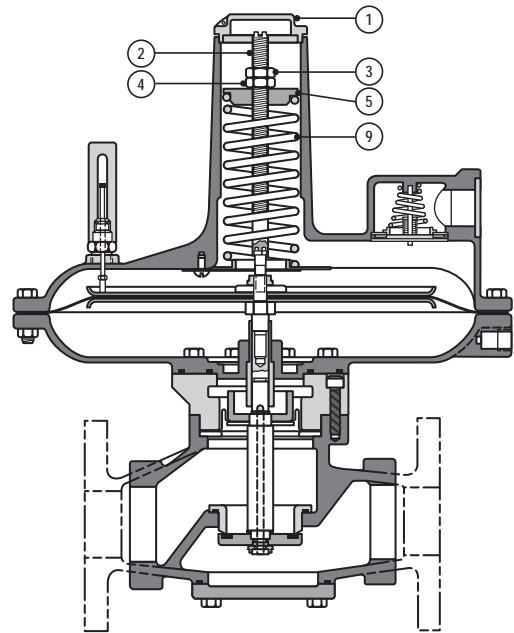

GIM1328-100

Vacuum Regulator

Vacuum Regulators are used to maintain a certain negative pressure (vacuum) in enclosed spaces such as tanks, vessels, chambers, piping systems, etc. In general, these are piped to the regulator inlet and control line connections and the regulator outlet piped to the inlet of a vacuum pump or other vacuum source.

Available pipe sizes are 3/4" thru 2 1/2", as listed on Page 23. Note on the cutaway drawing that the spring assembly is arranged for an upward force on the valve. Also, the valve itself is normally open and moves downward to close rather than upward as in the standard 121. With the exception of certain parts involved in the foregoing, everything else is interchangeable with standard 121 regulators.

Vacuums and Springs

Size	Vacuum Range w.c. vacuum (-w.c.)	Spring Color	Spring Part Number
3/4", 1" and 1 1/4" Model 121-8	3" to 6 1/2"	Red-Black	143-82-021-00
	5" to 8 1/2"	Blue-Black	143-82-021-01
	8" to 14"	Green-Black	143-82-021-02
	12" to 20"	Blue	143-16-021-04
	18" to 30"	Green	143-16-021-05
1 1/2", 2" and 2 1/2" Model 121-12	3" to 6 1/2"	Red	143-16-021-03
	5" to 8 1/2"	Blue	143-16-021-04
	8" to 14"	Green	143-16-021-05

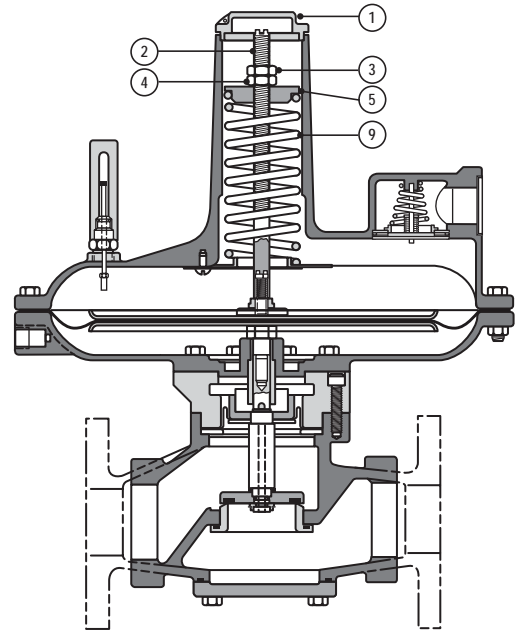

GIM1328-105

To Service Vacuum Breaker or Vacuum Regulator

1. Remove cover cap 1. Measure depth from top of cover to ferrule 5 for assembly.
2. Hold Stem 2 from turning using screwdriver on end of stem.
3. Unlock nut 3 from nut 4, then remove nut 3.
4. Slowly remove nut 4 maintaining pressure on spring ferrule 5 to prevent ejection of the spring from the upper case.

Caution:

Do not allow stem 2 to unscrew during removal of nut 4.

5. Remove spring 9.
6. To service vacuum breaker, follow procedure for standard regulators by size.
7. To service vacuum regulator, follow procedure for back pressure regulators by size.

121-RPC (Relay Pilot Control)

The 121-RPC is a genuine **Pilot Operated Regulator** (Relay Principal of Operation).

The relay principal means exceptional precise control. Accuracy is largely unaffected by changes in the inlet pressure.

The control line is piped to both the inlet and main regulator. The loading pressure to the main regulator varies with the downstream pressure resulting in precise regulation. Available in 1½", 2" and 2½" pipe sizes. The outlet pressure ranges from 3½" w.c. through 35 psig. Note on the cutaway drawing that the main spring is reversed to provide the upward closing force.

Outlet Pressure Range	Pilot Spring Spring Color	Pilot Spring Spring Part Number
3½" to 6½" w.c.	Red	143-08-021-00
5" to 8½" w.c.	Blue	143-08-021-01
6" to 14" w.c.	Green	143-08-021-02
12" to 28" w.c.	Orange	143-08-021-03
1 psig to 2 psig	Black	143-08-021-06
1 psig to 5 psig	White	138-18-021-01
3 psig to 15 psig	Gray	138-18-021-04
10 psig to 35 psig	Brown	138-18-021-03
3½" w.c. to 5 psig	Aluminum	138-18-021-05

Set-Point Adjustment

The 121-RPC is factory-adjusted as specified on the order.

To change the set-point:

- Remove pilot seal cap **10** and loosen lock nut **12**.

Caution:
Do not remove main cover cap **1**. The upper case is sealed and pressurized. The main spring does not contribute to set-point adjustment.
- Rotate set-point adjustment **11** clockwise to increase or counterclockwise to decrease the outlet pressure.

Caution:

 - There should be gas flow through the regulator during adjustment, preferably small (approximately 250 SCFH).
 - Do not adjust set point when there is no flow.
- When the desired set-point is achieved, retighten lock-nut **12** and install seal cap **10**. Make sure tetraseal **13**, is not damaged.

Pilot Spring Change

The outlet pressure range of the 121-RPC is determined by the pilot spring (see table of Outlet Pressure Ranges).

To change the spring:

NOTE: Do not change main spring **9**. It does not contribute to set-point adjustment.

- Take regulator out of service per the following section "Shut Down".
- Remove pilot seal cap **10**, loosen lock nut **12**, and turn set-point adjustment **11** counterclockwise until spring compression is released.

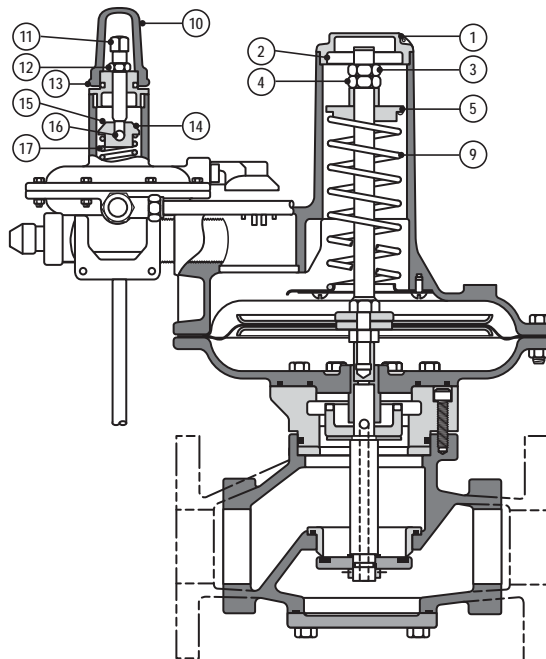

GIM1328-110

- Remove top cap **14**, ferrule **15**, and spring **17**. Be careful not to lose ball **16**.
- Install new spring. During reassembly make sure the spring is nested correctly at both ends.
- Adjust to the desired set-point per previous section "Set-Point Adjustment".

To Service 121-RPC

- Take regulator out of service per section "Shut Down".
- Remove cover cap **1**. Measure depth from top of cover to ferrule **5** for reassembly.
- Hold stem **2** from turning using screwdriver on end of stem.
- Unlock nut **3** from nut **4** and remove nut **3**.
- Slowly remove nut **4** maintaining pressure on the spring ferrule **5** to prevent ejection of the spring from the upper case.

Caution:
Do not allow stem **2** to unscrew during removal of nut **4**.
- Remove spring **9**.
- At pilot, disconnect control line which connects to downstream piping.
- Disconnect pilot supply line between body and pilot regulator.
- Follow procedures for standard 121 regulators by size.

121-PL (Pressure Loaded)

The 121-PL is a pressure loaded, Pilot Operated Regulator. The pressure loading of the diaphragm minimizes droop caused by spring and diaphragm effect, thus providing more accurate control. The outlet set pressure is controlled by adjusting the pilot regulator of the 121-PL. The main regulator spring is **NOT** to be adjusted. The two available pressure ranges are 3½" w.c. to 20 psig and 3½" w.c. to 35 psig, governed by two available pilot regulators.

Set-Point Adjustment

The 121-PL is factory adjusted as specified on the order.

To change set-point:

1. Loosen lock nut **12** on pilot regulator top
2. Rotate set-point adjustment **11** of pilot regulator clockwise to increase or counter clockwise to decrease the outlet pressure.
3. When the desired set-point is achieved, retighten lock-nut **12**.



CAUTION

Do not remove main cover cap 1. The upper case is sealed and pressurized. The main spring is not to be adjusted to control outlet pressure.

To Service 121-PL

1. Take regulator out of service per section "Shut Down".
2. Remove cover cap **1**. Measure depth from top of cover to ferrule **5** for reassembly.
3. Hold stem **2** from turning using screwdriver on end of stem.
4. Unlock nut **3** from nut **4** and remove nut **3**.
5. Slowly remove nut **4** maintaining pressure on the spring ferrule **5** to prevent ejection of the spring from the upper case.

Caution:

Do not allow stem **2** to unscrew during removal of nut **4**.

6. Remove spring **9**.
7. At pilot, disconnect control line which connects to downstream piping.
8. Disconnect pilot supply line between body and pilot regulator.
9. Follow procedures for standard 121 regulators by size.

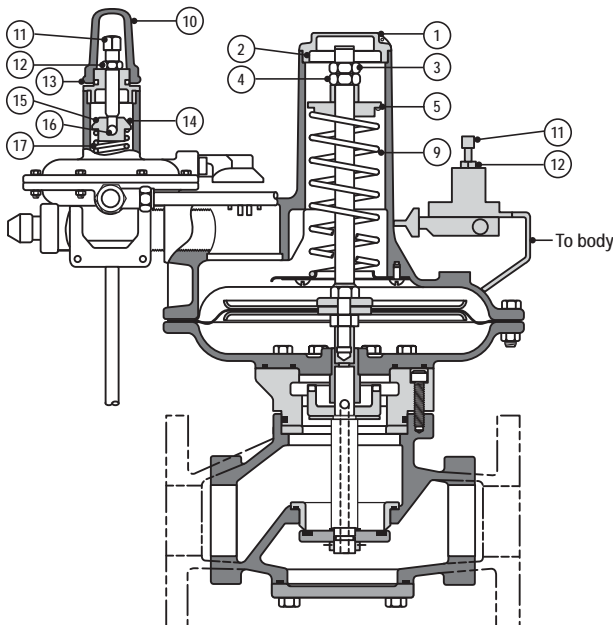

Model 121 Regulators

Maximum Emergency Pressures

The Maximum inlet pressures model 121 bodies may be subjected to under abnormal conditions without causing internal damage are as follows:

1" through 2½" pipe sizes	70 psi
3" pipe size.....	50 psi
4" pipe size.....	25 psi

The maximum pressures the diaphragms in model 121 regulators may be subjected to under abnormal conditions without causing internal damage are as follows:

Model 121-8	set-point plus 5 psi
Model 121-8HP	set-point plus 10 psi
Model 121-12	set-point plus 5 psi
Model 121-16	set-point plus 2 psi

Set-point is defined as the outlet pressure a regulator is adjusted to deliver.

If any of the above limits are exceeded the regulator must be taken out of service and inspected. Damaged or otherwise unsatisfactory parts must be repaired or replaced before returning the regulator to service.

The maximum pressures that can be safely contained by model 121 diaphragm cases are as follows:

Model 121-8	25 psi
Model 121-8HP	25 psi
Model 121-12	20 psi
Model 121-16	10 psi

Safely contained means no leakage as well as no bursting.

Before using any of the above data, make sure this entire section is clearly understood.

Full Open Capacity

Capacity of the model 121 in the wide-open position can be calculated using the following formula and K factors:

$$1. Q = K\sqrt{P_0(P_1 - P_0)}$$

$$2. Q = \frac{K P_1}{2}$$

Q = maximum capacity of the regulator
(in SCFH of 0.6 specific gravity natural gas)

K = the regulator constant "K" factor;

P₀ = **absolute** inlet pressure (psia)

P₁ = **absolute** outlet pressure (psia)

Use formula 1, when $\frac{P_1}{P_0}$ is less than 1.894.

Use formula 2, when $\frac{P_1}{P_0}$ is greater than 1.894.

3. K Factors =

1" Pipe Size (outlet)	K = 1400
1¼" Pipe Size (outlet)	K = 1750
1½" Pipe Size	K = 2750
2" Pipe Size	K = 4750
2½" Pipe Size	K = 5250
3" Pipe Size	K = 11000
4" Pipe Size	K = 18000

Remember, at the above full open capacities the droop is significantly greater than specified in the capacity tables. When checking 121 regulator capacity to provide adequate relief valve capacity, use the above calculated full open capacity.

Over-pressurization Protection

Protect the downstream piping system and the regulator's low pressure chambers against over-pressurization due to the possible regulator malfunction or failure to achieve complete lockup.

The allowable outlet pressure is the lowest of the maximum pressures permitted by federal codes, state codes, Sensus Bulletin RDS-1498 or other applicable standards. The method of protection can be a relief valve, monitor regulator, shutoff device or similar mechanism.

Materials of Construction

Body and Adapter	Cast Iron
Diaphragm Case (8" and 12" Diaphragm) (16" Diaphragm)	Die Cast Aluminum Alloy Permanent Mold Aluminum Alloy
Main and Seal Diaphragms	Buna-N or Nylon
Piston for Seal Diaphragm (¾" thru 2½" Model 121)	Powdered Iron Zinc Plated
Piston for Seal Diaphragm (3" and 4" Model 121)	Aluminum Alloy
Stem, Stud, Pans and Plates for 8", 12", & 16" Diaphragms	Plated Steel
Stem Bushing	Stainless Steel
Orifice (¾" thru 1¼" Model 121) (1½" thru 4" Model 121)	Brass Cast Iron
Retaining Ring (1½" thru 4" Model 121)	Plated Steel
Valve	Plated Steel with Molded Buna-N Soft Seal
Valve Wing	Plated Steel (3" Model 121)
Valve Holder	Plated Steel
Retaining Ring and Wave Washer	Stainless Steel
O-rings and Tetraseals	Buna-N
Adjustment Spring Ferrule	Zinc Die Casting
Bottom Spring Button	Powdered Iron-Plated
Adjustment Screw (16" Diaphragm) and H.P. Adjustment Spring Screw	Plated Steel
Adjustment Ferrule (16" Diaphragm) and H.P. Adjustment Spring Ferrule	Cast Iron
Seal Cap (8" and 12" Diaphragm) (16" Diaphragm)	Zinc Die Casting Die Cast Aluminum Alloy

Body Taps

Inlet and outlet taps are available on either side of the body. Tap sizes are ¼" NPT. Refer to "dimensions" on Page 23. Desired taps must be specified when ordering.

Other Gases

Model 121 Regulators are most widely used on natural gas. However, they perform equally well on LP gas, nitrogen, dry CO₂, air and other noncorrosive gases.

Other Gases	Correction Factor
Air (Specific Gravity 1.0)	0.77
Propane (Specific Gravity 1.53)	0.63
1350 BTU Propane-Air Mix (Specific Gravity 1.20)	0.71
Nitrogen (Specific Gravity 0.97)	0.79
Dry Carbon Dioxide (Specific Gravity 1.52)	0.63

For other non-corrosive gases:

$$\text{CORRECTION FACTOR} = \sqrt{\frac{0.60}{\text{Specific gravity of the gas}}}$$

Dimensions

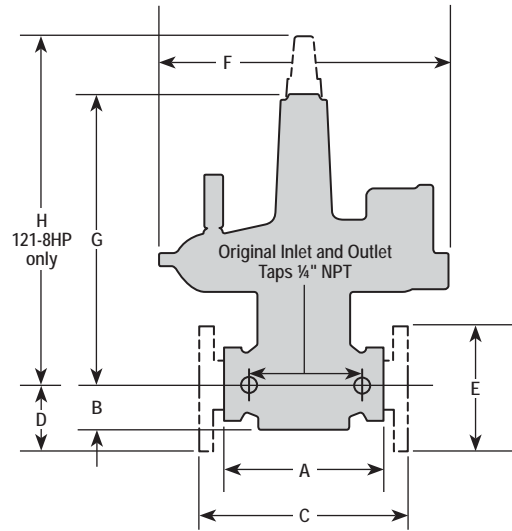

GIM1328-115

Pipe Size (inches)	Model Number	Screwed NPT		Flanged ANSI 125 FF			F (dia.)	G	High Pressure Spring Adjustment
		A	B	C	D	E			
3/4 – 1 – 1 1/4	121-8 & 8HP	5 3/4	1 7/8	–	–	–	10 3/16	13 3/16	19 1/8
1 1/2	121-8 & 8HP	7 1/2	2 3/8	–	–	–	10 3/16	13 3/16	19 1/4
1 1/2	121-12	7 1/2	2 3/8	–	–	–	14	14 1/8	–
2	121-8 & 8HP	7 1/2	2 3/8	10	3	6	10 3/16	13 11/16	19 1/4
2	121-12	7 1/2	2 3/8	10	3	6	14	14 1/8	–
2 1/2	121-8 & 8HP	8 1/4	2 3/8	–	–	–	10 3/16	13 11/16	19 1/4
2 1/2	121-12	8 1/4	2 3/8	–	–	–	14	14 1/8	–
3	121-12	11 3/4	3 9/16	11 3/4	3 3/4	7 1/2	14	15 5/8	–
3	121-16	11 3/4	3 9/16	11 3/4	3 3/4	7 1/2	18	19	–
4	121-12	–	–	13 3/4	4 1/2	9	14	16 1/2	–
4	121-16	–	–	13 3/4	4 1/2	9	18	20	–

Model 121 Regulators

Installation and Maintenance Instructions



Authorized Distributor:

All products purchased and services performed are subject to Sensus terms of sale, available at either: <http://na.sensus.com/TC/TermsConditions.pdf> or 1-800-METER-IT. Sensus reserves the right to modify these terms and conditions in its own discretion without notice to the customer.

This document is for informational purposes only, and SENSUS MAKES NO EXPRESS WARRANTIES IN THIS DOCUMENT. FURTHERMORE, THERE ARE NO IMPLIED WARRANTIES, INCLUDING WITHOUT LIMITATION, WARRANTIES AS TO FITNESS FOR A PARTICULAR PURPOSE AND MERCHANTABILITY. ANY USE OF THE PRODUCTS NOT SPECIFICALLY PERMITTED HEREIN IS PROHIBITED.