



Presentation example PME7...

Presentation example LME7...

## PME71.402...

## Program module for burner control LME71.000

### User Documentation

- Application:**
- 1-stage, direct or pilot ignited forced draft burners
  - E.g. for burners to EN 676

The PME7... and this User Documentation are intended for use by OEMs which integrate the LME7... with PME7... in their products.



**Note!**  
This documentation is only valid together with LME7... Basic Documentation (P7105)!

# Contents

1	Supplementary documentation .....	3
2	Warning notes .....	4
3	Typographical conventions .....	4
4	Program sequence PME71.402.....	5
5	List of phase display .....	6
6	Fuel trains (examples) .....	7
6.1	Gas direct ignition (G), 1-stage .....	7
6.2	Gas pilot ignition 1 (Gp1/1), 1-stage .....	7
7	Input gas pressure switch-min .....	7
8	Time table and settings .....	8
9	Inputs and outputs / internal connection diagram .....	9
10	Parameter list (AZL2... ).....	10
11	Error code list.....	13
12	Legend .....	14
13	List of figures .....	15

# 1 Supplementary documentation

Product type	Type of documentation	Documentation number
LME...	Environmental Product Declaration	E7105
PME...	Environmental Product Declaration	E7105.1
LME7...	Data Sheet	N7105
LME...	Product Range Overview	Q7010
LME7	Basic Documentation	P7105

## 2 Warning notes



### Warning!

The safety, warning and technical notes given in the Basic Documentation on the LME7... (P7105) apply fully to the present document also!

To avoid injury to persons, damage to property or the environment, the following warning notes must be observed!

The LME7... are safety devices! Do not open, interfere with or modify the unit. Siemens does not assume responsibility for damage resulting from unauthorized interference!

## 3 Typographical conventions

### Safety notes

This User Documentation contains notes which must be observed to ensure your personal safety and to protect the product and the connected equipment. The instructions and notes are highlighted by warning triangles or a hand symbol and are presented as follows, depending on the hazard level:



#### Warning

means that death, severe personal injury or substantial damage to property **can** occur if adequate precautionary measures are not taken



#### Note

draws your attention to **important information** on the product, on product handling, or to a special part of the documentation

### Qualified personnel

Only **qualified staff** are allowed to install and operate the equipment. Qualified staff in the context of the safety-related notes contained in this document are persons who are authorized to commission, ground and tag devices, systems and electrical circuits in compliance with established safety practices and standards.

### Correct use

*Note the following:*

The device may only be used on the applications described in the technical documentation and only in connection with devices or components from other suppliers that have been approved or recommended by Siemens.

The product can only function correctly and safely if shipped, stored, set up and installed correctly, and operated and maintained as specified.

# 4 Program sequence PME71.402...

→ For fuel trains **G** and **Gp1/1**

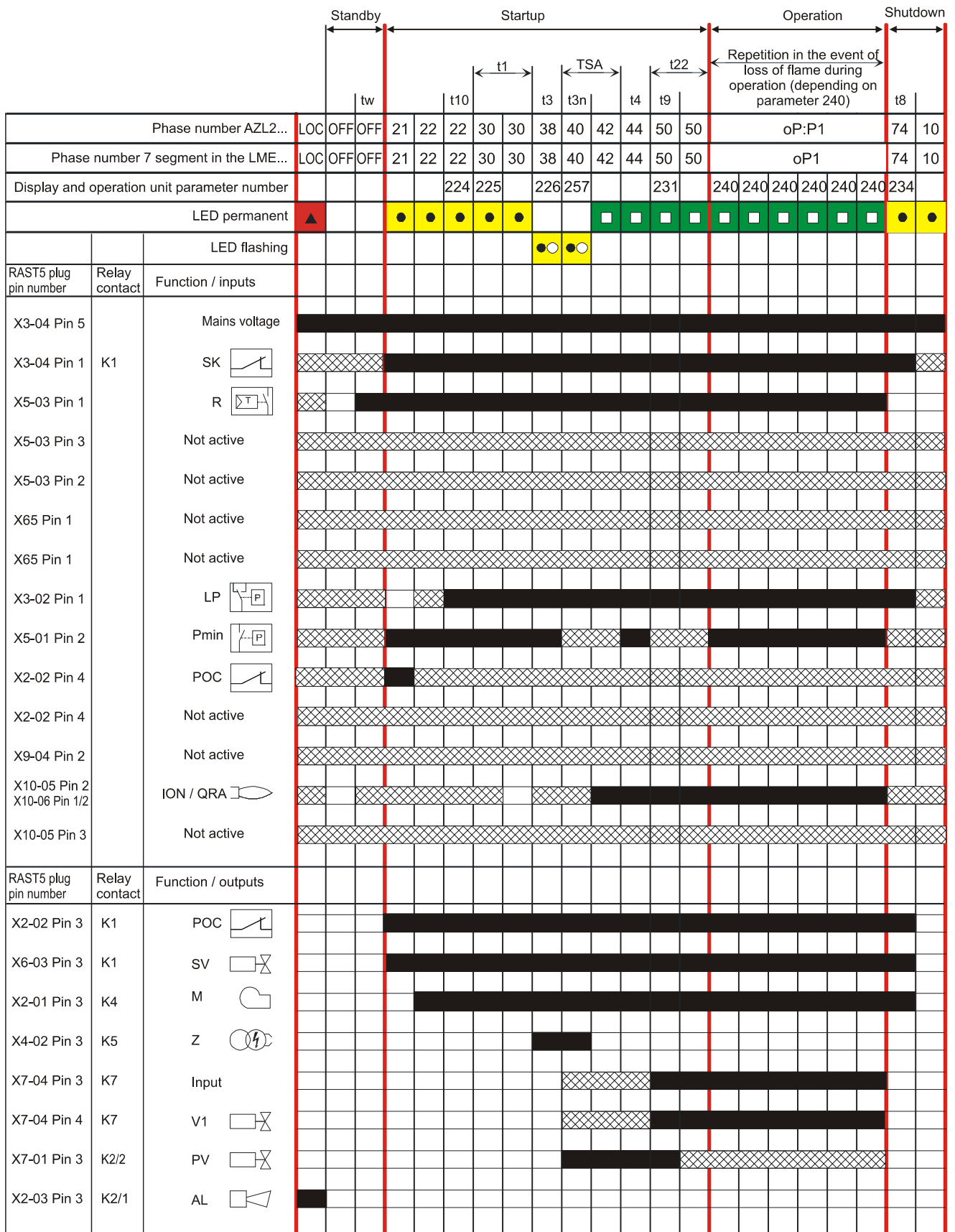

Figure 1: Program sequence

7105d70e/0611

## 5 List of phase display

Phase number of display		LED	Function
7-segment	AZL2...		
LOC	LOC	OFF	Lockout phase
<b>Standby</b>			
OFF	OFF	OFF	Standby, waiting for heat request
P08	Ph08	OFF	Power ON/test phase (e.g. detector test)
<b>Startup</b>			
P21	Ph21	Yellow	Safety valve ON, air pressure switch in no-load position Test if POC closed (timeout/lockout after 5 seconds)
P22	Ph22	Yellow	Part 1: Fan motor ON Part 2: Specified time air pressure switch Message (timeout), stabilization air pressure switch
P30	Ph30	Yellow	Part 1: Prepurge time without extraneous light test Part 2: Prepurging with extraneous light test (2.1 seconds)
P38	Ph38	Yellow flashing	Preignition time
P40	Ph40	Yellow flashing	Postignition time
P42	Ph42	Green	Flame detection
P44	Ph44	Green	Interval: End of safety time and fuel valve 1 ON
P50	Ph50	Green	Part 1: Interval: Fuel valve 1 ON and pilot valve OFF Part 2: Flame-out response time
<b>Operation</b>			
oP1	oP:P1	Green	Operation
<b>Shutdown</b>			
P10	Ph10	OFF	Home run
P74	Ph74	Yellow	Postpurge time
<b>Safety shutdown phases</b>			
P01	Ph01	Yellow / red	Under voltage / over voltage
P02	Ph02	Yellow	Safety shutdown (e.g. open safety loop) → Lockout
P04	Ph04	Green / red	Extraneous light in standby
P90	Ph90	Yellow	Gas pressure switch-min open → safety shutdown and start prevention

## 6 Fuel trains (examples)

### 6.1 Gas direct ignition (G), 1-stage

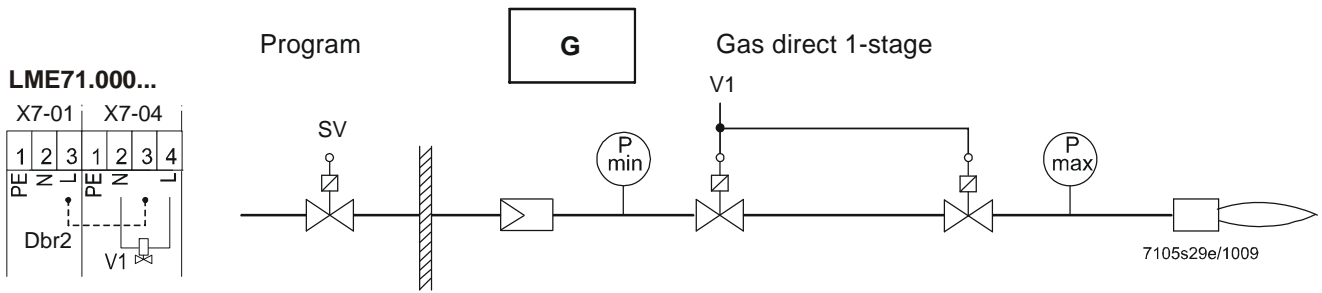

Figure 2: Fuel train gas direct ignition (G), 1-stage

### 6.2 Gas pilot ignition 1 (Gp1/1), 1-stage

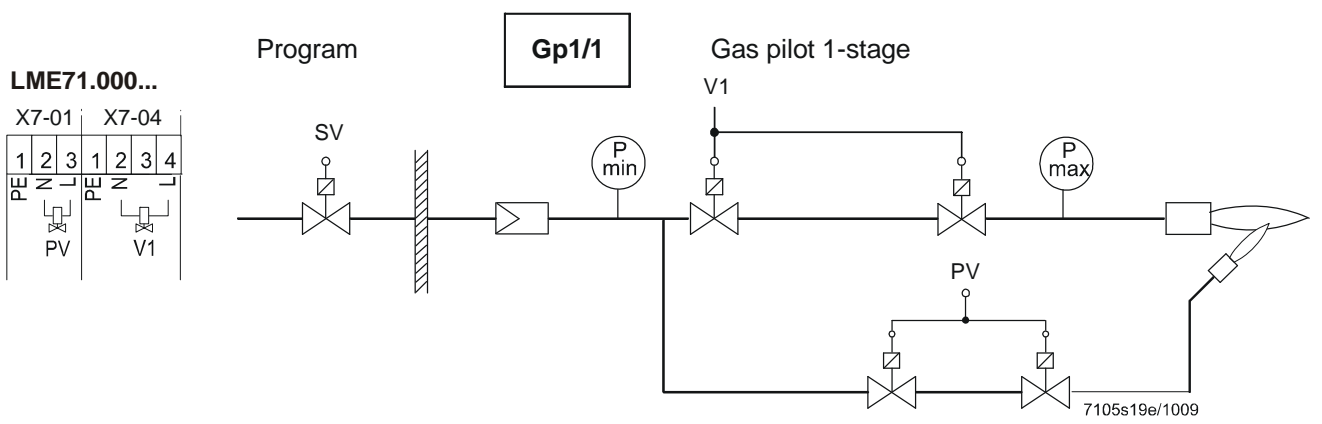

Figure 3: Fuel train gas pilot ignition 1 (Gp1/1), 1-stage

## 7 Input gas pressure switch-min

Behavior in the event gas pressure switch-min fails (terminal X5-01 pin 2 and 3)

If gas pressure switch-min fails, safety shutdown is triggered and startup prevented until gas pressure switch-min closes again. During start prevention, the yellow LED is lit and the safety circuit is active. Burner control operates in phase 90.

## 8 Time table and settings

Type	Times in seconds												
	tw	TSA max.	t1 P225 min.	t3 P226 min.	t3n P257 approx.	t4 P230 min.	t8 P234 min.	t9 P231 approx.	t10 P224 approx.	t22 approx.	1)	2)	3)
Requirements	2.5	3	30	3	2.5	3	15	3	15	---	---	---	---
Factory setting	---	t3n+0.45	29.106+2.1	3.087	2.205+0.3	3.234	19.404	2.646	13.818	t9+1	---	---	---
Max.	2.5	14	1237+2.1	37.485	13.23+0.3	74.97	1237	74.97	13.818	---	1	0.45	0.45
Min.	---	---	0+2.1	1.029	0+0.3	3.234	0	0	0	---	0.3	0.3	---
Step size	---	---	4.851	0.147	0.147	0.294	4.851	0.294	0.294	---	---	---	---

Function parameter	Parameter number	Factory setting
Repetition in the event of loss of flame during operation 0 = none 1 = none 2 = 1 x repetition	240	0
Continuous pilot (during operation) 0: OFF 1: ON	247	0

### Legend

- tw Waiting time
- TSA Safety time
- t1 Prepurge time
- t3 Preignition time
- t3n Postignition time parameter 257 +0.3 seconds
- t4 Interval: End of safety time - fuel valve 1 ON
- t8 Postpurge time
- t9 Interval: Fuel valve 1 ON and pilot valve OFF
- t10 Specified time air pressure switch message (timeout)
- t22 2nd safety time

- 1) Reaction time to a change of signal by the air pressure switch contact (opens) and flame-out response time in the event of loss of flame
- 2) Reaction time to a change of signal by the inputs (e.g. pressure switch-min)
- 3) Flame detection time



# 9 Inputs and outputs / internal connection diagram

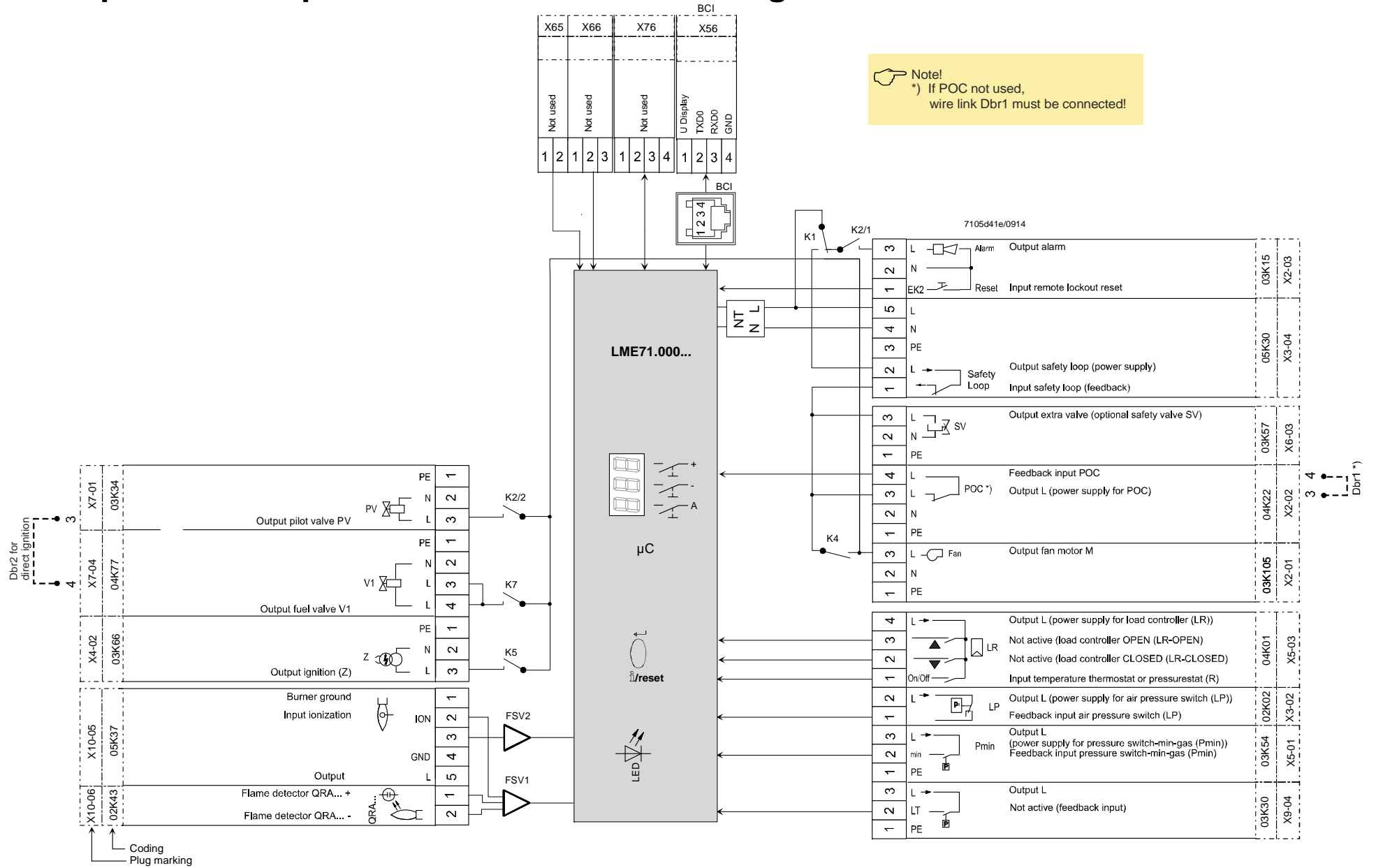

Figure 4: Inputs and outputs / internal connection diagram

## 10 Parameter list (AZL2...)

Parameter-number	Parameter	Edit	Value range		Resolution	Factory setting	Password level reading from level	Password level writing from level
			Min.	Max.				
<b>000</b>	<b>Internal parameter</b>							
41	Heating engineer's password (4 characters)	Edit	xxxx	xxxx	---	---	---	OEM
42	OEM's password (5 characters)	Edit	xxxxx	xxxxx	---	---	---	OEM
60	Backup/restore	Edit	---	---	---	---	---	SO
<b>100</b>	<b>General</b>							
102	Identification date	Read only	---	---	---	---	Info	---
103	Identification number	Read only	0	9999	1	0	Info	---
113	Burner identification	Edit	x	xxxxxxxx	1	---	Info	SO
140	Mode display of display and operating unit AZL2... 1 = standard (program phase) 2 = flame 1 (QRA.../ION) 3 = flame 2 (QRB.../QRC...) ⇒ not used 4 = active power (power value)	Edit	1	4	1	1	SO	SO
164	Number of startups resettable	Resettable	0	999999	1	0	Info	Info
166	Total number of startups	Read only	0	999999	1	0	Info	---
170.00	Switching cycles relay contact K12	Read only	0	999999	1	0	Info	---
170.01	Switching cycles relay contact K11	Read only	0	999999	1	0	Info	---
170.02	Switching cycles relay contact K2	Read only	0	999999	1	0	Info	---
170.03	Switching cycles relay contact K1	Read only	0	999999	1	0	Info	---
171	Max. switching cycles relay	Read only	0	999999	1	0	Info	---





Parameter number	Parameter	Edit	Value range		Resolution	Factory setting	Password level reading from level	Password level writing from level
			Min.	Max.				
<b>200</b>	<b>Burner control</b>							
224	Specified time air pressure switch	Edit	0 s	13.818 s	0.294 s	13.818 s	SO	OEM
225	Prepurge time -2.1 seconds	Edit	0 s	1237 s	4.851 s	29.106 s	SO	OEM
226	Preignition time	Edit	1.029 s	37.485 s	0.147 s	3.087 s	SO	OEM
230	Interval: End of safety time - fuel valve 1 ON	Edit	3.234 s	74.97 s	0.294 s	3.234 s	SO	OEM
231	Interval: Fuel valve 1 ON - pilot valve OFF	Edit	0 s	74.97 s	0.294 s	2.646 s	SO	OEM
234	Postpurge time	Edit	0 s	1237 s	4.851 s	19.404 s	SO	OEM
240	Repetition in the event of loss of flame during operation 0: None 1: None 2: 1 x repetition	Edit	0	2	1	0	SO	OEM
247	Continuous pilot (during operation) 0: OFF 1: ON	Edit	0	1	1	0	SO	OEM
257	Postignition time -0.3 seconds	Edit	0 s	13.23 s	0.147 s	2.205 s	SO	OEM

Parameter number	Parameter	Edit	Value range		Resolution	Factory setting	Password level reading from level	Password level writing from level
			Min.	Max.				
<b>700</b>	<b>Error history</b>							
701	Current error: 00: Error code 01: Startup meter reading 02: HMI phase 03: Power value	Read only	2 0 --- 0%	255 999999 --- 100%	1 1 --- 1	---	Service	---
702	Error history former 1: 00: Error code 01: Startup meter reading 02: HMI phase 03: Power value	Read only	2 0 --- 0%	255 999999 --- 100%	1 1 --- 1	---	Service	---
• • •								
711	Error history former 10: 00: Error code 01: Startup meter reading 02: HMI phase 03: Power value	Read only	2 0 --- 0%	255 999999 --- 100%	1 1 --- 1	---	Service	---
<b>900</b>	<b>Process data</b>							
936	Normalized speed	Read only	0%	100%	0.01%	---	Service	---
951	Mains voltage	Read only	0 V	LME71.000A1: 175 V LME71.000A2: 350 V	1 V	---	Service	---
954	Flame intensity	Read only	0%	100%	1%	---	Service	---

# 11 Error code list

Error code		Clear text	Possible cause
AZL2...	7-segment		
Loc: 2	Loc 2	No establishment of flame at the end of safety time	<ul style="list-style-type: none"> <li>- Faulty or soiled fuel valves</li> <li>- Faulty or soiled flame detector</li> <li>- Poor adjustment of burner, no fuel</li> <li>- Faulty ignition equipment</li> </ul>
Loc: 3	Loc 3	Air pressure faulty (air pressure switch welded in no-load position, decrease to specified time (air pressure switch flame-on response time))	<ul style="list-style-type: none"> <li>- Air pressure switch faulty</li> <li>- Loss of air pressure signal after specified time</li> <li>- Air pressure switch has welded in no-load position</li> </ul>
Loc: 4	Loc 4	Extraneous light	Extraneous light during burner startup
Loc: 5	Loc 5	Air pressure faulty, air pressure switch welded in working position	<ul style="list-style-type: none"> <li>- Time supervision air pressure switch</li> <li>- Air pressure switch has welded in working position</li> </ul>
Loc: 7	Loc 7	Loss of flame	<ul style="list-style-type: none"> <li>- Too many losses of flame during operation (limitation of repetitions)</li> <li>- Faulty or soiled fuel valves</li> <li>- Faulty or soiled flame detector</li> <li>- Poor adjustment of burner</li> </ul>
Loc: 10	Loc 10	Error not relatable (application), internal error	Wiring error or internal error, output contacts, other faults
Loc: 14	Loc 14	POC error	Error valve closure control POC
Loc: 22	Loc 22	Safety loop open	<ul style="list-style-type: none"> <li>- Gas pressure switch-max open</li> <li>- Safety limit thermostat cut out</li> </ul>
Loc: 138	Loc 138	Restore process successful	Restore process successful
Loc: 139	Loc 139	No program module detected	No program module plugged in
Loc: 167	Loc 167	Manual locking	Manual locking
Loc: 206	Loc 206	AZL2... incompatible	Use the latest version
rSt Er1	rSt Er1	Error in compatibility program module to basic unit during restore process	- Program sequence of program module does not match the basic unit
rSt Er2	rSt Er2	Error in compatibility program module to basic unit during restore process	- Hardware of basic unit does not match the program module
rSt Er3	rSt Er3	Error during restore process	<ul style="list-style-type: none"> <li>- Program module faulty</li> <li>- Program module removed during restore process</li> </ul>
bAC Er3	bAC Er3	Fault of compatibility program module to basic unit during backup process	Program sequence of program module does not match the basic unit
Err PrC	Err PrC	Fault of program module	<ul style="list-style-type: none"> <li>- Error in data content of program module</li> <li>- No program module fitted</li> </ul>

## 12 Legend

AL	Alarm device
Dbr...	Wire link
 i/reset (EK1)	Lockout reset button (info button)
EK2	Remote lockout reset button
FSV	Flame signal amplifier
ION	Ionization probe
K...	Relay contact
LED	3-color signal lamp
LP	Air pressure switch
LR	Load controller
LR-OPEN	Load controller OPEN position
LR-CLOSED	Load controller CLOSED position
M	Fan motor
NT	Power supply unit
Pmax	Pressure switch-max
Pmin	Pressure switch-min
POC	Valve closure control (proof of closure)
PV	Pilot valve
QRA...	Flame sensor
R	Control thermostat or pressurestat
SK	Safety Loop
SV	Safety valve
V1	Fuel valve
Z	Ignition transformer
	Input/output signal 1 (ON)
	Input/output signal 2 (OFF)
	Permissible input signal 1 (ON) or 0 (OFF)

# 13 List of figures

---

Figure 1: Program sequence .....	5
Figure 2: Fuel train gas direct ignition (G), 1-stage .....	7
Figure 3: Fuel train gas pilot ignition 1 (Gp1/1), 1-stage .....	7
Figure 4: Inputs and outputs / internal connection diagram.....	9