

Chicago Valves & Controls

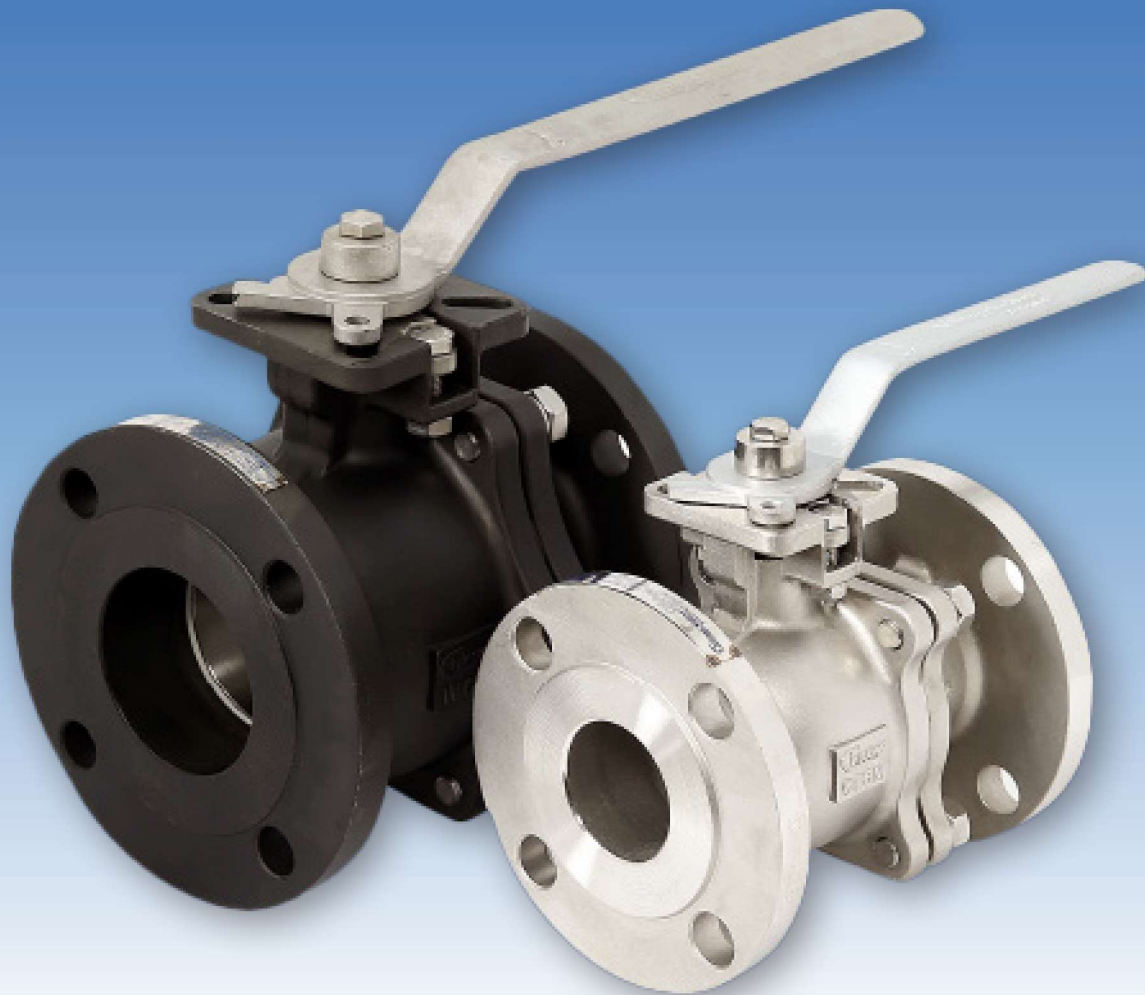

SERIES 82/FS82

FLANGED FULL PORT

BALL VALVE CLASS 150/300/600

Series 82 | FS82

150# / 300# / 600#

1/2" - 6"

316 STAINLESS STEEL - ASTM A351
 CARBON STEEL - ASTM A216 WCB
 ALLOY 20 - ASTM A351 CN7M
 LIVE LOADED STEM
 LOCKABLE HANDLE
 DIRECT MOUNT MOUNTING PAD

MC PAD:
 ELEVATED PAD ALLOWS FOR ADJUSTMENT
 OF GLAND PACKING FLANGE WHILE VALVE IS
 IN SERVICE WITHOUT REMOVING ACTUATOR
 OR HANDLE, API 608
 ELEVATED PAD ALLOWED TO ADJUST
 GLAND PACKAGING FLANGE WHILE
 VALVE IS IN SERVICE WITHOUT
 REMOVING ACTUATOR OR HANDLE,
 API 608

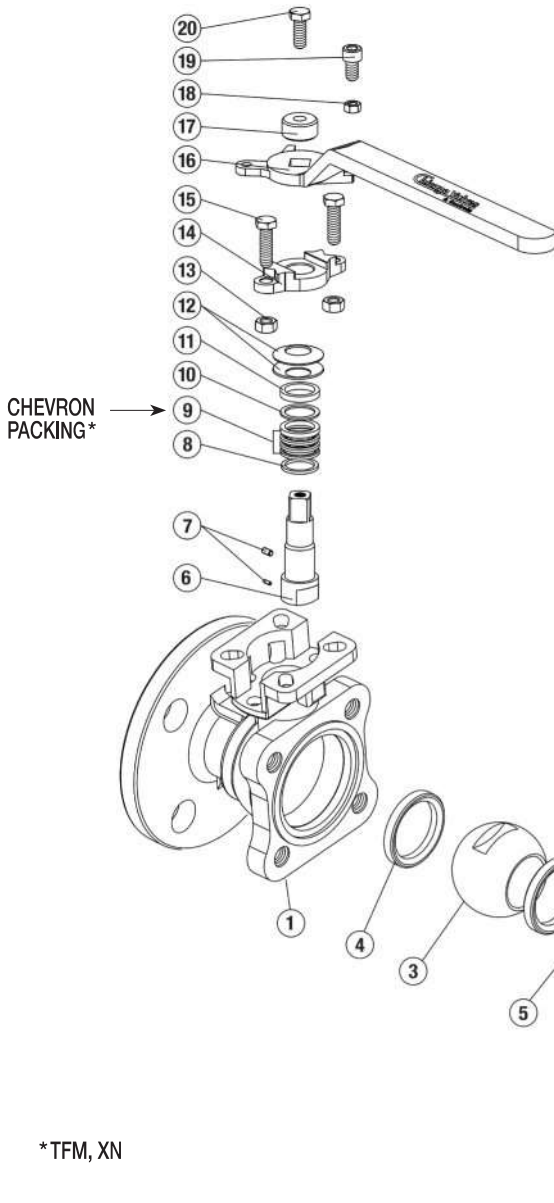

PART NO	PART NAME	QTY	MATERIAL
1	BODY	1	CARBON STEEL ASTM A216 WCB 316 STAINLESS STEEL ASTM A351 CF8M ALLOY 20 ASTM CN7M SMO 254® ASTM A351 CK3CUN
2	END PIECE	1	CARBON STEEL ASTM A216 WCB 316 STAINLESS ASTM A351 CF8M ALLOY 20 ASTM CN7M SMO 254® ASTM A351 CK3MCUN
3	BALL	1	316 STAINLESS STEEL ALLOY 20 ASTM CN7M SMO 254® ASTM A351 CK3MCUN
4	SEAT	2	RTFE, TFM®, XN, PEEK
5	BODY SEAL	1	PTFE, GRAPHITE
6	STEM	1	316 STAINLESS STEEL, ALLOY 20 17-4PH, SMO 254
7	ANTI-STATIC DEVICE	2	316 STAINLESS STEEL HARD DRAWN STAINLESS STEEL
8	THRUST WASHER	1	XN (Carbon Fill TFM)
9	STEM PACKING	4	TFM, XN (Carbon Fill TFM), Graphite
10	LANTERN RING	1	XN (Carbon Fill TFM)
11	GLAND	1	304 STAINLESS STEEL
12	BELLEVILLE WASHER	2	304 STAINLESS STEEL
13	GLAND FLANGE NUT	2	A194 B8
14	GRAND FLANGE	1	304 STAINLESS STEEL CF8
15	GLAND FLANGE BOLT	2	A193 B8
16	HANDLE	1	304 STAINLESS STEEL CF8 CARBON STEEL A216 WCB
17	STEM CAP	1	304 STAINLESS STEEL
18	STOPER NUT	1	A194 8
19	STOPER BOLT	1	A193 B8
20	STEM CAP BOLT	1	A193 B8
21	BODY STUD	4 6 8	A193 B8
22	SPRING WASHER	4 6 8	304 STAINLESS STEEL
23	BODY NUT	4 6 8	A194 B
24	HANDLE TEE	1	STAINLESS STEEL, CARBON STEEL
25	HANDLE TEE BOLT	1	A193 B8
26	HANDLE TEE PIPE	1	STAINLESS STEEL, CARBON STEEL

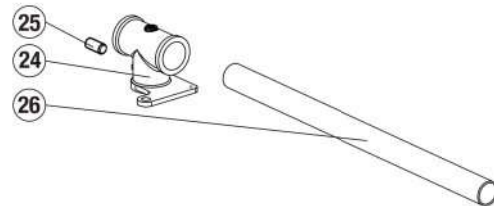

*TFM, XN

Series 82 | FS82

150# / 300#
8" - 12"

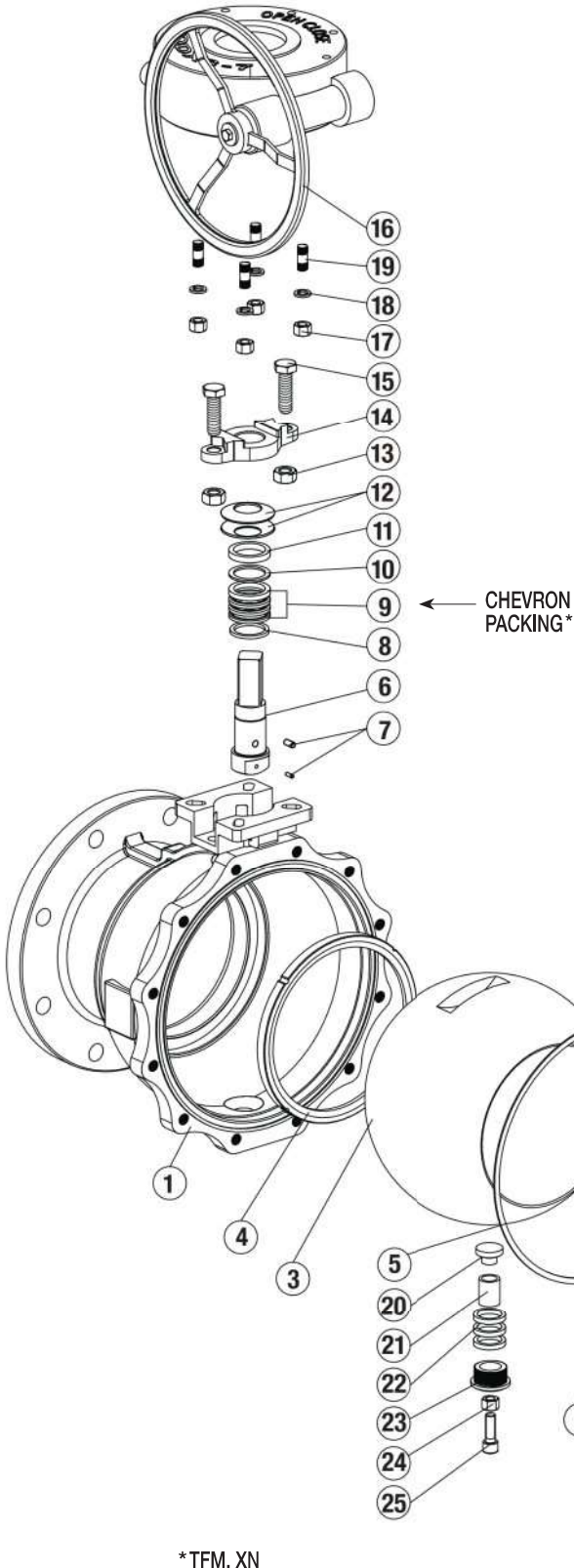

PART NO	PART NAME	QTY	MATERIAL
1	BODY	1	CARBON STEEL ASTM A216 WCB 316 STAINLESS STEEL ASTM A351 CF8M ALLOY 20 ASTM A351 CN7M SMO 254 [®] ASTM A351 CK3CUN
2	END PIECE	1	CARBON STEEL ASTM A216 WCB 316 STAINLESS STEEL ASTM A351 CF8M ALLOY 20 ASTM A351 CN7M SMO 254 [®] ASTM A351 CK3CUN
3	BALL	1	316 STAINLESS STEEL ALLOY 20 SMO 254 [®]
4	SEAT	2	RTFE, TFM [®] , XN, PEEK
5	BODY SEAL	1	PTFE, GRAPHITE
6	STEM	1	316 STAINLESS STEEL, ALLOY 20 17-4PH, SMO 254 [®]
7	ANTI-STATIC DEVICE	2	316 STAINLESS STEEL HARD DRAWN STAINLESS STEEL
8	THRUST WASHER	1	XN (Carbon Fill TFM)
9	STEM PACKING	4	TFM, XN (Carbon Fill TFM), Graphite
10	LANTERN RING	1	XN (Carbon Fill TFM)
11	GLAND	1	304 STAINLESS STEEL
12	BELLEVILLE WASHER	2	300 STAINLESS STEEL
13	GLAND FLANGE NUT	2	A194 8
14	GLAND FLANGE	1	304 STAINLESS STEEL CF8
15	GLAND FLANGE BOLT	2	A193 B8
16	GEAR OPERATOR	1	WORMGEAR OPERATOR
17	GO NUT	4	A194 8
18	GO SPRING WASHER	4	304 STAINLESS STEEL
19	GO BOLT	4	A193 B8
20	BALL SUPPORT SEAT	1	PTFE
21	BALL SUPPORT SHAFT	1	304 STAINLESS STEEL
22	BALL SUPPORT PACKING	1	TFM
23	BALL SUPPORT NUT	1	304 STAINLESS STEEL
24	SET NUT	1	A194 8
25	TUNING SCREW	1	A193 B8
26	BODY STUD	12 16	A193 B8
27	SPRING WASHER	12 16	300 STAINLESS STEEL
28	NUT	12 16	A194 8
29	HANDLE TEE BOLT	1	STAINLESS STEEL, CARBON STEEL
30	HANDLE TEE	1	A193 B8
31	HANDLE TEE PIPE	1	STAINLESS STEEL, CARBON STEEL

*TFM, XN

Series 82 | FS82

1/2" - 4"
Class 150#

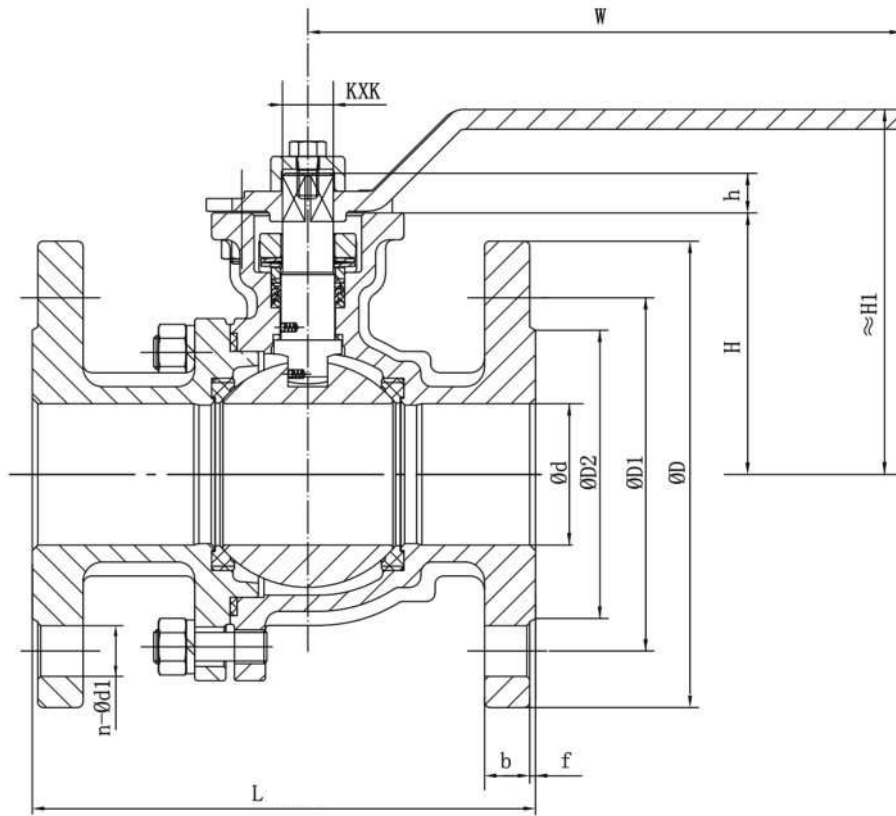
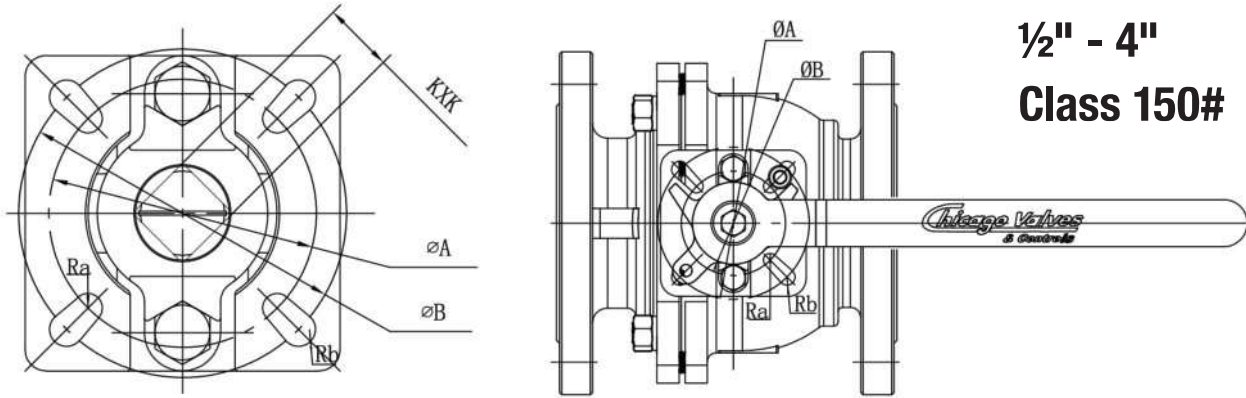

DIMENSIONS (INCHES)

NOMINAL DIAMETER	L	d	D2	D1	D	b	f	n-ød1	H	h	H1	W	Ra	Rb	KXK	A	B
1/2"	4.25	0.59	1.38	2.37	3.54	0.37	0.08	4-0.63	2.20	0.35	3.39	5.91	0.12	0.14	0.35X0.35	F03	F05
3/4"	4.62	0.79	1.69	2.75	3.94	0.39	0.08	4-0.63	2.38	0.35	3.56	5.91	0.12	0.14	0.35X0.35	F03	F05
1"	5.00	0.98	2.01	3.13	4.33	0.41	0.08	4-0.63	2.68	0.43	3.94	7.08	.012	0.14	0.43X0.43	F04	F05
1 1/2"	6.50	1.58	2.87	3.87	4.92	.50	0.08	4-0.63	3.37	0.55	4.78	8.27	0.14	0.17	0.55X0.55	F05	F07
2"	7.00	1.97	3.62	4.75	5.91	.56	0.08	4-0.75	3.64	0.55	5.06	8.27	0.14	0.17	0.55X0.55	F05	F07
2 1/2"	7.50	2.56	4.13	5.50	7.09	.063	0.08	4-0.75	4.43	0.67	6.00	10.24	0.17	0.22	0.67X0.67	F07	F10
3"	8.00	3.15	5.00	6.00	7.48	.069	0.08	4-0.75	4.92	0.67	6.73	12.99	0.17	0.22	0.67X0.67	F07	F10
4"	9.00	3.94	6.18	7.50	9.06	0.88	0.08	8-0.75	5.53	0.67	7.34	12.99	0.17	0.22	0.67X0.67	F07	F10

Series 82 | FS82

1/2" - 4"
Class 300#

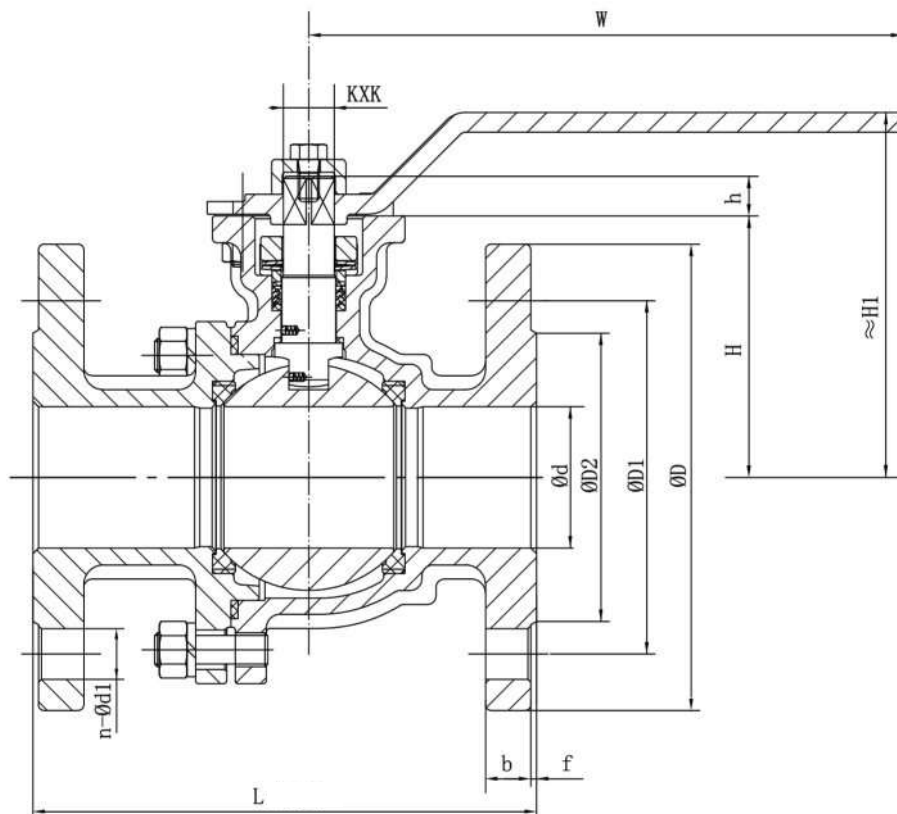
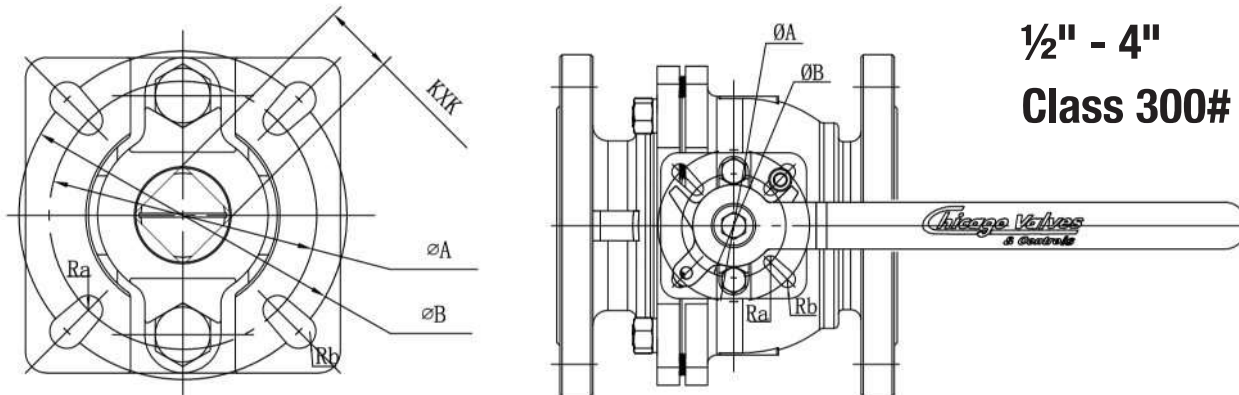

DIMENSIONS (INCHES)

NOMINAL DIAMETER	L	d	D2	D1	D	b	f	n-ød1	H	h	H1	W	Ra	Rb	KXK	A	B
1/2"	5.50	0.59	1.38	2.63	3.74	0.50	0.08	4-0.63	2.20	0.35	3.39	5.91	0.12	0.14	0.35X0.35	F03	F05
3/4"	6.00	0.79	1.69	3.25	4.53	0.56	0.08	4-0.75	2.38	0.35	3.56	5.91	0.12	0.14	0.35X0.35	F03	F05
1"	6.50	0.98	2.01	3.50	4.92	0.63	0.08	4-0.75	2.68	0.43	3.94	7.09	.012	0.14	0.43X0.43	F04	F05
1 1/2"	7.50	1.58	2.87	4.50	6.10	0.75	0.08	4-0.87	3.37	0.55	4.78	8.27	0.14	0.17	0.55X0.55	F04	F07
2"	8.50	1.97	3.62	5.00	6.50	0.81	0.08	8-0.75	3.64	0.55	5.06	8.27	0.14	0.17	0.55X0.55	F05	F07
2 1/2"	9.50	2.56	4.13	5.87	7.48	0.94	0.08	8-0.87	4.43	0.67	6.00	10.24	0.17	0.22	0.67X0.67	F05	F10
3"	11.12	3.15	5.00	6.63	8.27	1.06	0.08	8-0.87	4.92	0.67	6.73	12.99	0.17	0.22	0.67X0.67	F07	F10
4"	12.00	3.94	6.18	7.87	10.04	1.19	0.08	8-0.87	5.53	0.67	8.90	25.60	0.22	0.26	0.67X0.87	F10	F12

Series 82 | FS82

1/2" - 4"
Class 600#

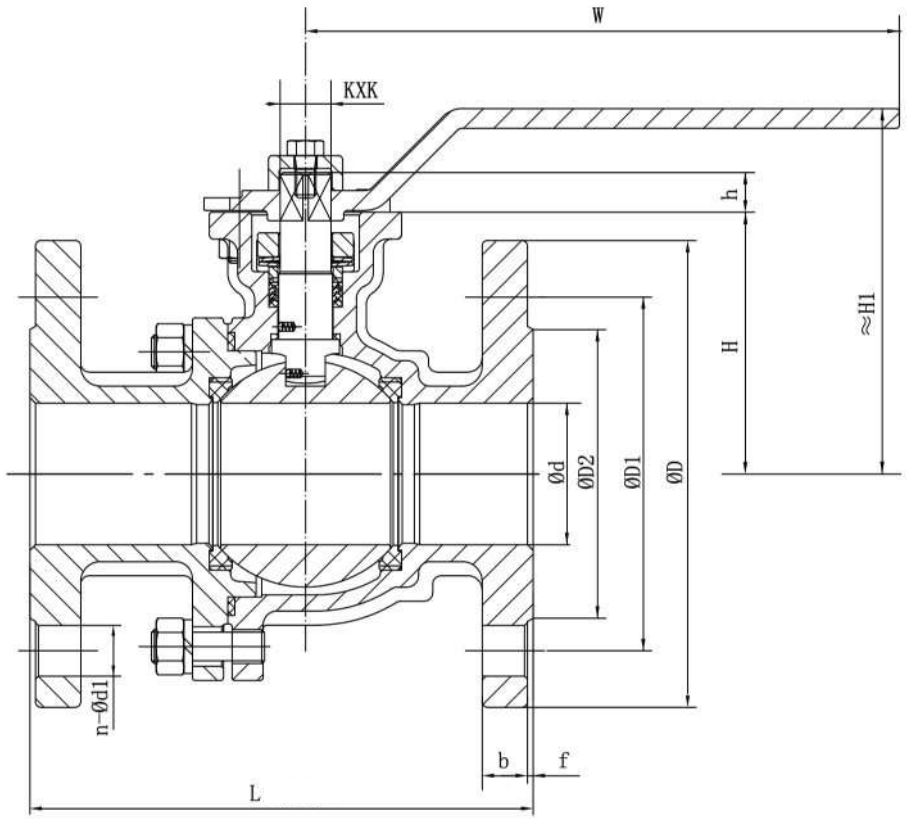
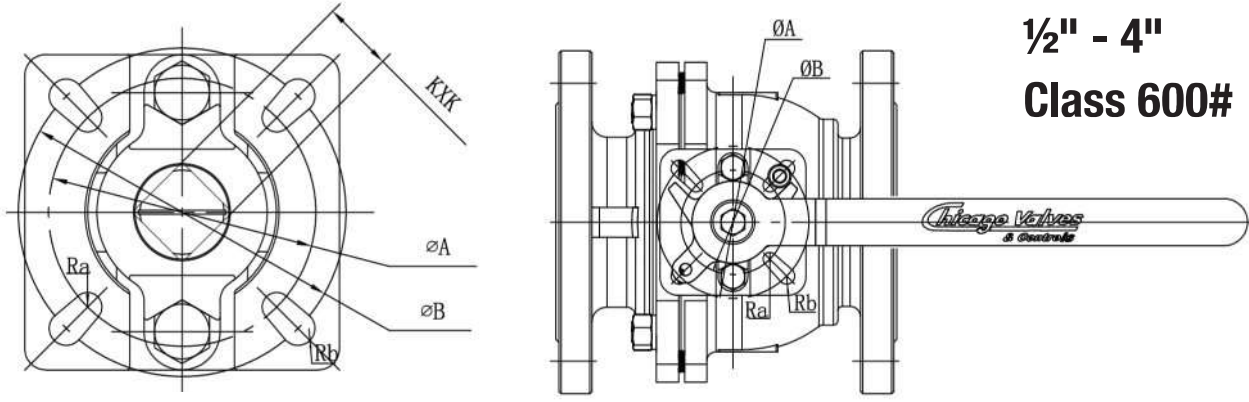

DIMENSIONS (INCHES)

NOMINAL DIAMETER	L	d	D2	D1	D	b	f	n- $\varnothing d1$	H	h	H1	W	Ra	Rb	KXK	A	B
1/2"	6.50	0.59	1.38	2.62	3.75	0.56	0.28	4-0.63	2.20	0.35	3.39	5.91	0.12	0.14	0.35X0.35	F03	F05
3/4"	7.50	0.79	1.69	3.25	4.62	0.62	0.28	4-0.75	2.38	0.35	3.56	5.91	0.12	0.14	0.35X0.35	F03	F05
1"	8.50	0.98	2.01	3.50	4.88	0.69	0.28	4-0.75	2.80	0.43	4.00	7.09	.012	0.14	0.43X0.43	F04	F05
1 1/2"	9.50	1.58	2.87	4.50	6.12	0.88	0.28	4-0.87	3.76	0.55	5.17	8.27	0.14	0.17	0.55X0.55	F05	F07
2"	11.50	1.97	3.62	5.00	6.50	1.00	0.28	8-0.75	4.02	0.55	5.44	8.27	0.14	0.17	0.55X0.55	F05	F07
2 1/2"	13.00	2.56	4.13	5.88	7.50	1.12	0.28	8-0.87	4.96	0.67	6.53	10.24	0.17	0.22	0.67X0.67	F07	F10
3"	14.00	3.15	5.00	6.63	8.25	1.25	0.28	8-0.87	5.55	0.67	7.36	12.99	0.17	0.22	0.67X0.67	F07	F10
4"	17.00	3.94	6.18	8.50	10.75	1.50	0.28	8-1.00	6.28	0.87	8.10	12.99	0.22	0.26	0.67X0.87	F10	F12

Series 82 | FS82

6"

Class 150# / 300#

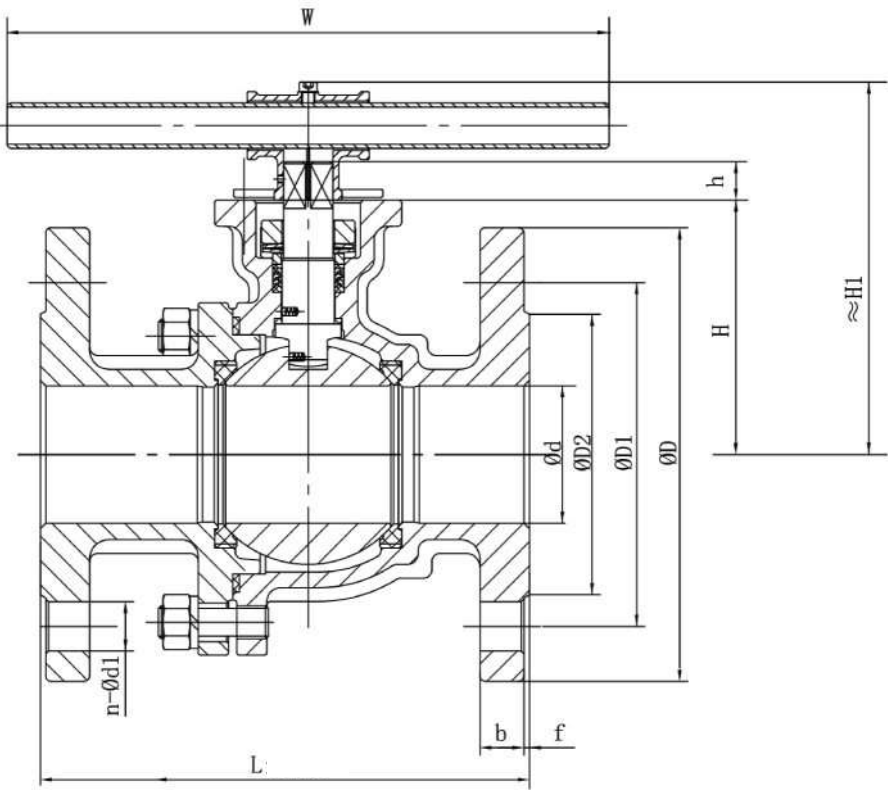
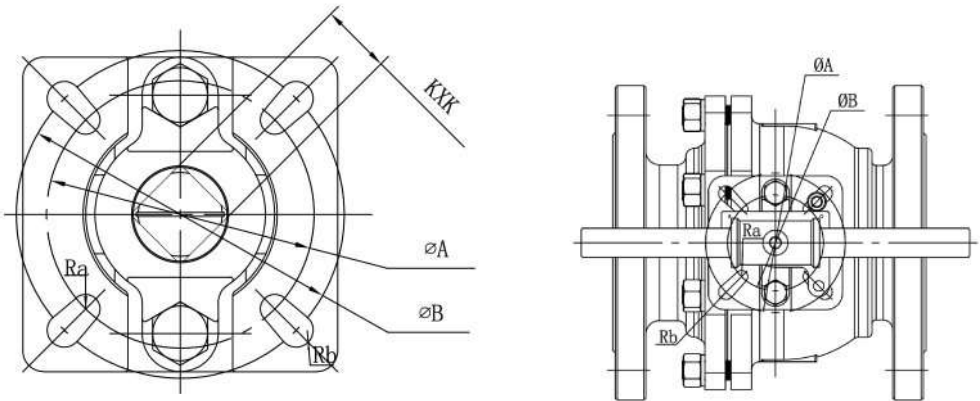

DIMENSIONS (INCHES)

NOMINAL DIAMETER	L	d	D2	D1	D	b	f	n-Ød1	H	h	H1	W	Ra	Rb	KXK	A	B
150 6"	15.50	5.91	8.50	9.50	11.04	094	0.08	8-0.87	7.56	1.18	10.91	31.50	0.22	0.26	1.06X1.06	F10	F12
300 6"	15.80	5.91	8.50	10.63	12.60	1.38	0.08	12-0.87	7.56	1.18	10.91	39.40	0.22	0.26	1.06X1.06	F10	F12

Series 821 FS82

8" - 12"
Class 150#

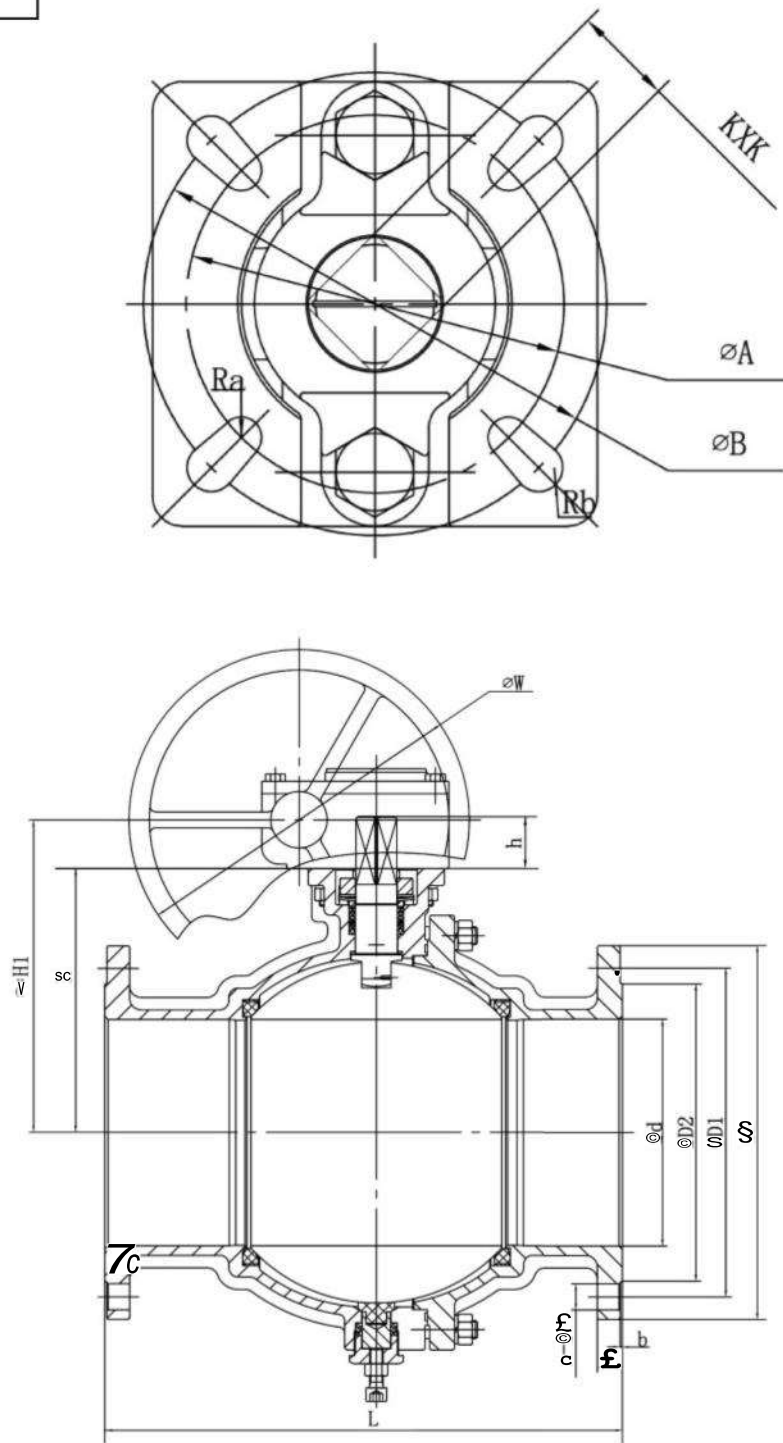

NOMINAL DIAMETER	L	d	D2	D1	D	b	f	n- ϕ f	H	h	H1	W	Ra	Rb	KXK	A	B
8"	18.00	7.87	10.63	11.75	13.58	1.06	0.08	8-0.87	9.21	1.38	11.02	11.81	0.22	0.26	1.42x1.42	F12	F14
10"	21.00	9.84	12.76	14.25	15.95	1.13	0.08	12-0.98	11.10	1.77	13.30	19.69	0.26	0.34	1.42X1.42	F12	F14
12"	24.00	11.81	15.00	17.00	18.98	1.19	0.08	12-0.98	12.85	1.77	15.04	19.69	0.26	0.34	1.42X1.42	F12	F14

Series 82 | FS82

8" - 12"
Class 300#

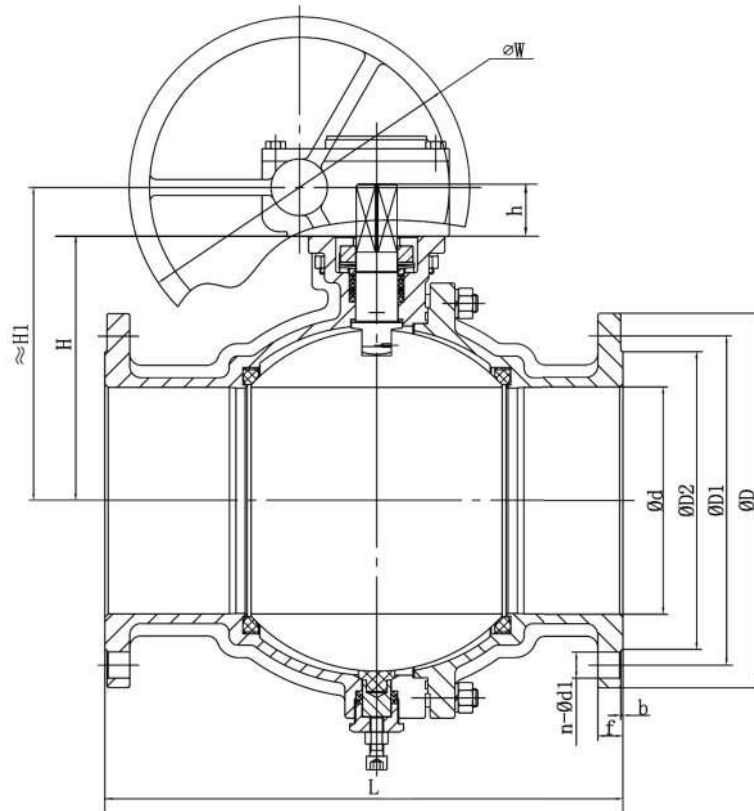
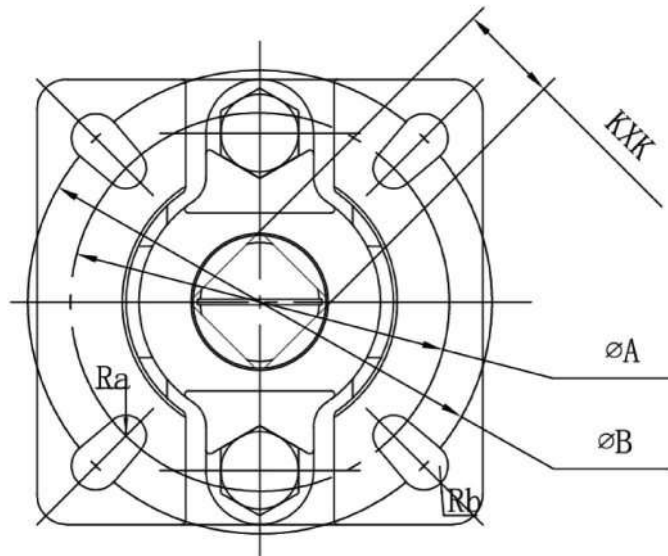

NOMINAL DIAMETER	L	d	D2	D1	D	b	f	n-ød1	H	h	H1	W	Ra	Rb	KXK	A	B
8"	18.00	7.87	10.63	11.75	13.58	1.06	0.08	8-0.87	9.21	1.38	11.02	11.81	0.22	0.26	1.06X1.06	F10	F12
10"	21.00	9.84	12.76	14.25	15.95	1.13	0.08	12-0.98	11.10	1.77	13.30	19.69	0.26	0.34	1.42X1.42	F12	F14
12"	24.00	11.81	15.00	17.00	18.98	1.19	0.08	12-0.98	12.85	1.77	15.04	19.69	0.26	0.34	1.42X1.42	F12	F14

APPLICABLE STANDARDS

APPLICABLE STANDARDS	
BASIC DESIGN	ASME B16.34
FACE TO FACE DIMENSION	ASME B16.5
FLANGE DIMENSION	ASME B16.5
TEST	API 608
MOUNTED PADS DIMENSION	ISO 5211
FIRES TEST	API 607 6TH EDITION
NACE	MR-0175 (WITH 316 STAINLESS STEEL STEM)

SRE	CV (GPM)	WEIGHT(LBS)		
		150#	300#	600#
1/2"	26	5.50	5.75	6.00
3/4"	50	5.50	7.75	8.00
1"	94	7.50	11.00	13.00
1 1/2"	260	14.00	21.75	24.00
2"	480	20.00	26.50	36.00
2 1/2"	750	32.00	42.00	55.00
3"	1300	42.00	60.00	80.00
4"	2300	65.00	90.00	137.00
6	4500	160.00	220.00	X
8	10,000	267.00	365.00	X
10	16,000	570.00	720.00	X
12	23,000	745.00	915.00	X

PRESSURE-TEMPERATURE RATINGS SERIES 82

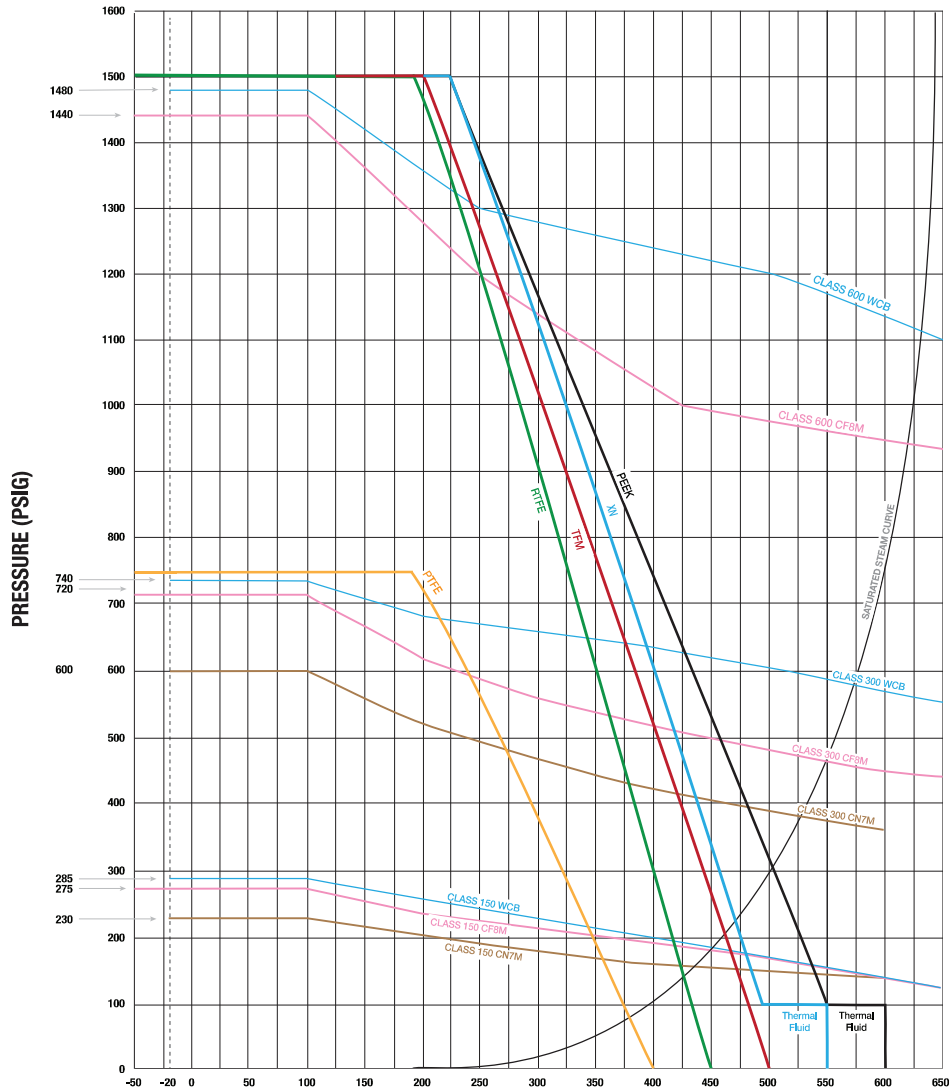

Note:
 The maximum pressure/temperature ratings of the valve assemblies are limited to lowest of the body or seat material fitted. The body ratings are based on ASME B16.34 rating for materials. The graphs are based on laboratory testing and our experience in field. The seat ratings depend on the material, design, application and function.

Chicago Valves & Controls® Seat Materials

M-TFM® PTFE

Dyneon TFME® PTFE is a second generation PTFE with improved chemical and heat resistant properties and stress recovery. Its temperature range is -100°F to 500°F (-73°C to 260°C) Color - white.

R-Reinforced Polytetrafluoroethylene (RTFE).

PTFE's mechanical properties are enhanced by adding 15% filler material to provide improved strength, stability and wear resistance. Its temperature range is from -320°F to 450°F (-196°C to 232°C). Color-off-white.

XN - is a free-flowing compound based on TFME® containing electro-graphitized carbon. It features: increased thermal dimensional stability and surface hardness, improved deformation under load, reduced friction and wear, and good chemical stability. It has a high limiting oxygen index (LOI), low coefficient of friction, very good mechanical properties and exceptional temperature resistance. It is used as a seat material in chemical processing and automotive industries. It is ideal to with steam and thermal fluid applications up to 550°F (228°C) and as low as -40°F (-40°C). Color -black.

P-PEEK (Unfilled) Polyetheretherketone

PEEK Polymer offers a unique combination of chemical, mechanical and thermal properties. Excellent for water and steam application at elevated temperatures up to 600°F (315°C). Color - beige.

Other seat materials

Other seat materials are available according to the application, such as very high temperature or cryogenic conditions.

HOW TO ORDER

1"	82	6 6 6 R	G G 3	X OH
Size	Series	Body & Ends Ball Stem Seats	Body Seal Stem Packing Class	Service Options
SIZE	SERIES	BODY & ENDS	OPTIONS	SERVICE
1/2"	82-Full Port	6 316 Stainless Steel	T PTFE	X Oxygen Service (CVAC Standards)
3/4"	*FS82-Fire Safe	4 Carbon Steel	G Graphite	SF Silicone FREE
1"		2 Alloy 20		
1-1/2"				
2"				
2-1/2"				
3"				
4"				
6"				
8"				
10"				
12"				
		BALL	STEM PACKING	OPTIONS
		6 316 Stainless Steel	M TFM	OH Oval Handle (Up to 2")
		2 Alloy 20	X XN**	VB Vented Ball
			G Graphite	SH Spring Loaded Handle (Up to 2")
		STEM		GO Gear Operator
		6 316 Stainless Steel	CLASS	
		2 Alloy 20	1 150RF	
		7 17-4PH	3 300RF	
			6 600RF	
		SEATS		
		M TFM*		
		X XN**		
		R RTFE 15% Glass Filled		
		P PEEK		

* Fire Safe Must Use Graphite Body Seals & Stern Packing, TFM®, XN, RT, SEATS

** XN - Carbon Filled TFM®

		Toll-Free (833) 831-2312 Local (312) 636-3557 Fax: (312) 637-3543 Email: sales@chicagovalves.com www.chicagovalve.com 835 Cambridge Dr. Elk Grove Village, Illinois 60007 U.S.A.

Due to ongoing development of our product line, specifications subject to change without notice.
Teflon® is a registered trademark of E.J. DuPont.

REV 12/19